



ADDENDUM TO THE CONTRACT

for the

CBJ HEADWORKS IMPROVEMENTS Contract No. BE17-033

ADDENDUM NO.: ONE

CURRENT DEADLINE FOR BIDS:
December 8, 2016

PREVIOUS ADDENDA: NONE

ISSUED BY: City and Borough of Juneau
ENGINEERING DEPARTMENT
155 South Seward Street
Juneau, Alaska 99801

PREVIOUS DEADLINE FOR BIDS:
December 8, 2016

DATE ADDENDUM ISSUED: December 1, 2016

The following items of the contract are modified as herein indicated. All other items remain the same. This addendum has been issued and is posted online. Please refer to the CBJ Engineering Contracts Division webpage at: <http://www.juneau.org/engineering ftp/contracts/Contracts.php>

PROJECT MANUAL:

- Item No. 1: SECTION 00030 – NOTICE INVITING BIDS, DEADLINE FOR BIDS. **Change** the Bid date **from** December 6, 2016, **to** December 8, 2016.
- Item No. 2: SECTION 00030 – NOTICE INVITING BIDS. **Delete** in its entirety and **replace** with the attached SECTION 00030 – NOTICE INVITING BIDS, labeled Addendum No. 1.
- Item No. 3: SECTION 00500 – AGREEMENT. **Delete** in its entirety and **replace** with the attached SECTION 00500 – AGREEMENT, labeled Addendum No. 1.
- Item No. 4: SECTION 011413 - SITE ACCESS AND STORAGE, PART 1 – GENERAL, Article 1.5 STORAGE, Paragraph A. **Add** the following:
- “At the Mendenhall plant, the Contractor will be permitted to site a 20 foot job trailer inside the property fence. Ingress and egress must be maintained at all times throughout the site. A maximum of 2 work trucks may be inside the property boundary; all additional vehicles will need to be parked outside the fenced areas. CBJ will provide a 15’ x 35’ conditioned workspace for storage of piping materials and screens for a maximum of 7 days before installation of each. Storage may be used during the 10 day shutdown. Storage must be arranged with the Utilities Superintendent a minimum of 7 days in advance of storage space being required. Temporary power is available but connection and power costs will be the Contractors responsibility per Section 015000.”
- Item No. 5: SECTION 011413 – SITE ACCESS AND STORAGE, PART 1 – GENERAL, Article 1.4 WORK RESTRICTIONS. **Add** paragraph G.

“G. No anchoring system may be installed at either facility that requires anchors or bolts to penetrate the facility walls without prior approval from the CBJ Utility Manager. Any anchoring system requests must include documentation that shows that the anchoring system will not cause harm to the existing walls, and must be structurally designed to support expected loads.”

Item No. 6: SECTION 011413 - SITE ACCESS AND STORAGE, PART 1 – GENERAL, Article 1.5 STORAGE. **Add** Paragraph D as follows:

“At the Juneau Douglas plant, the Contractor will be permitted to site a 20’ job trailer inside the CBJ property fence. Temporary power is available but connection and power costs will be the Contractors responsibility per Section 015000.”

Item No. 7: SECTION 017300 - EXECUTION, PART 3 – EXECUTION, Article 3.5 - INSTALLATION, **Add** Paragraphs K and L.

“K. At the Mendenhall plant, the Contractor shall completely cover the exposed grating on both the basement and ground level with steel plate, wood planking, or material approved by the Engineer to prevent material from falling into the channels or wet well. The covers shall remain in place throughout the duration of the project.”

“L. The trolley system and hoist has a maximum load of 2 tons. The Contractor shall not overload either the trolley system or hoist. For the Contractor to use the crane/hoist system at the Mendenhall plant the following conditions must be met:

1. Contractor shall have an OSHA certified hoist/crane operator, an OSHA certified rigger (class II or higher), and a trained signals person. Certificates must be supplied to CBJ before work begins and operating personnel must match the certification credentials.”

Item No. 8: SECTION 051200 - STRUCTURAL STEEL FRAMING, PART 1 – GENERAL, Article 1.6 - QUALITY ASSURANCE, Paragraph B. - Installer Qualifications. **Delete** this Article in its entirety.

Item No. 9: SECTION 055213 - PIPE AND TUBE RAILING, PART 1 – GENERAL, Article 1.1 – SUMMARY. **Delete** Paragraph B.

Item No. 10: SECTION 061000 - ROUGH CARPENTRY, PART 2 – PRODUCTS, Article 2.3 – FRAMING, Paragraph A. **Add** the following to the last sentence: “or certified by a Certification Organization accredited by the Forest Stewardship Council.”

Item No. 11: SECTION 074213.13 - FORMED METAL WALL PANELS, PART 1 – GENERAL, Article 1.11 - WARRANTY, Paragraph B. Special Warranty on Panel Finishes. **Delete** in its entirety Subparagraph 1. Exposed Panel Finish.

Item No. 12: SECTION 074213.13 - FORMED METAL WALL PANELS, PART 2 – PRODUCTS, Article 2.2 – EXPOSED-FASTENER, LAP-SEAM METAL WALL PANELS, Paragraph B – Vee-Rib-Proville, Exposed-Fastener Metal Wall Panels, Subparagraph 2. Metallic-Coated Steel Sheet, Item b. Exterior Finish. **Replace** “three-coat fluoropolymer” **with** “two-coat fluoropolymer”.

- Item No. 13: SECTION 074213.13 - FORMED METAL WALL PANELS, PART 2 – PRODUCTS, Article 2.5 - FINISHES, Paragraph C – Steel Panels and Accessories, Subparagraph 1. Three-Coat Fluoropolymer. **Replace** “Three-Coat Fluoropolymer” **with** “Two-Coat Fluoropolymer”.
- Item No. 14: SECTION 074213.53 - METAL SOFFIT PANELS, PART 1 – GENERAL, Article 1.10 – WARRANTY, Paragraph B. Special Warranty on Panel Finishes. **Delete** in its entirety Subparagraph 1. Exposed Panel Finish.
- Item No.15: SECTION 075423 – THERMOPLASTIC POLYOLEFIN (TPO) ROOFING, PART 2 – PRODUCTS, Article 2.7 - INSULATION ACCESSORIES, Paragraph B. **Change** title of paragraph to “Non Penetrating Mechanically Fastened Roofing System”.
- Item No. 16: SECTION 075423 – THERMOPLASTIC POLYOLEFIN (TPO) ROOFING, PART 3 – EXECUTION, Article 3.5 - MECHANICALLY FASTENED ROOFING INSTALLATION, Paragraph D. **Delete** the words “Mechanically or adhesively”.
- Item No. 17: SECTION 076200 - SHEET METAL FLASHING AND TRIM, PART 2 – PRODUCTS, Article 2.2 – SHEET METALS, Paragraph A. Prepainted, Metallic-coated Steel Sheet:, Subparagraph 2. Exposed Finishes, Item a. High-Performance Organic Finish, subitem 1 Fluoropolymer 3-Coat System. **Replace** “Flouropolymer 3-Coat System” **with** “Flouropolymer 2-Coat System”.
- Item No. 18: SECTION 083323 - OVERHEAD AND COILING DOORS, PART 2 – PRODUCTS, Article 2.3 - DOOR ASSEMBLY, Paragraph K – Door Finish. **Change** door finish from “hot dip galvanized” **to** “manufacturer’s standard powder coat finish, in color selected from manufacturer’s standard range of colors.”

DRAWINGS:

- Item No. 19: PLAN SHEET MP-02, PROPOSED EQUIPMENT SCHEDULE, Item 9. **Replace** “side outlet tee, grv” **with** “side outlet 90 degree elbow, grv”.
- Item No. 20: PLAN SHEET JA-05. **Replace** with the attached revised sheet JA-05.
- Item No. 21: PLAN SHEET JA-05, DOOR AND RELITE SCHEDULE. **Add** the following note:
 “Provide Hardware Set 1 described in SECTION 087100 – DOOR HARDWARE at door 101. All hardware for door 102 to be provided by Coiling Door manufacturer as described in SECTION 083323 – OVERHEAD COILING DOORS”.
- Item No. 22: PLAN SHEETS JS-06 AND JS-07. **Delete** all references to “Schedule 40 - Aluminum Handrail.” All handrails shall be galvanized steel per Specification Section 055213 - PIPE AND TUBE RAILING.
- Item No. 23: PLAN SHEET JS-07, Details 4 & 5. **Add** NOTE 2.
 “2. The grating for the top platform should be rotated to span the 4'-5" distance or use 1-1/4" x 1/4" Series GHB for the 6'-10" span.”
- Item No. 24: PLAN SHEET JA-09. **Replace** with the attached revised SHEET JA-09.

Item No. 25: PLAN SHEET JA-10, Detail1. **Change** the note "Rhinobond fastener" **to** "Induction welded fastener."

Item No. 26: PLAN SHEET JA-12. **Replace** with the attached revised PLAN SHEET JA-12.

Item No. 27: PLAN SHEET JA-12: Add the following note to details 3 and 4: "Scuppers to be 8" wide".

By: 
Greg Smith,
Contract Administrator

Total number of pages contained within this Addendum: 17

SECTION 00030 NOTICE INVITING BIDS

OBTAINING CONTRACT DOCUMENTS. The Contract Documents are entitled:

**CBJ Headworks Improvements
Contract No. BE17-033**

The Contract Documents may be obtained at the City & Borough of Juneau (CBJ) Engineering Department, 3rd Floor Marine View Center, upon payment of \$75.00 (non-refundable) for each set of Contract Documents (including Technical Specifications and Drawings) or may be downloaded for free at the CBJ Engineering Department webpage at: www.juneau.org/engineering

PRE-BID CONFERENCE. Prospective Bidders are encouraged to attend a pre-Bid conference to discuss the proposed WORK, which will be conducted by the OWNER at 9:00 a.m. on November 18, 2016, at the Mendenhall Valley Wastewater Treatment Plant, 2009 Radcliffe Road. The object of the conference is to acquaint Bidders with the project and bid documents. There will be a walk-through of both facilities following the meeting.

DESCRIPTION OF WORK. The WORK is generally described as follows:

Mendenhall Valley Wastewater Treatment Plant (MWWTP): The improvements to the headworks includes removal of one existing automatic screen and grinder system and one manual bar screen, the installation of two new perforated plate screens and screening washer/compactors including new electrical connections to the screens and compactors, dismantling and removing an oil/water separation tank, relocating an existing grit classifier clarifier and conveyor, and modifications to the piping in the influent pump station, painting of pipe, installation of gas alarms, and miscellaneous related WORK. Installation of the new screens will require construction sequencing to dismantle and replace existing 16-inch and 18-inch ductile iron pipe and new 24-inch process piping to make space for the new screens.

Juneau-Douglas Wastewater Treatment Plant (JDTP): The improvements to the headworks includes the installation of two new perforated plate automatic screens and screening washer/compactors including new electrical connections to the screens and compactors, construction of new concrete influent channels and piping to connect the new influent channels to existing piping, construction of a new building around the new channels and miscellaneous related WORK. Site grading includes the installation of two new catch basins, new storm drain lines, and asphalt restoration. Demolition includes the removal of the existing automatic screen and manual screen, removal of existing concrete steps, removal of a timber framed wall and soffit, and removal of electrical feeds to the existing screens. Construction sequencing will be required to maintain the existing headworks in operation while the new screens and channels are construction.

COMPLETION OF WORK. The WORK must be completed according to the table below.

<u>Work Description</u>	<u>Completion Date</u>
MWWTP	September 1, 2017
Influent Piping Replacement	10 days from approved start date.
JDTP	November 1, 2017

Influent piping replacement completion date: 10 days from approved bypass start date (bypass is allowed April 1 – May 31, 2017, contractor may not commence influent piping replacement until CBJ pump replacement project is completed)

SECTION 00030 NOTICE INVITING BIDS

DEADLINE FOR BIDS: Sealed bids must be received by the Purchasing Division **prior to 2:00 p.m., Alaska Time on December 8, 2016**, or such later time as may be announced by addendum at any time prior to the deadline. Bids will be time and date stamped by the Purchasing Division, which will establish the official time of receipt of bids. Bids will be opened immediately thereafter in the Assembly Chambers of the Municipal Building, 155 S. Seward Street, unless otherwise specified.

Bid documents delivered in person or by **courier** service must be delivered to:

Bid documents delivered by **U.S. Postal Service** must be mailed to:

PHYSICAL LOCATION:

City and Borough of Juneau, Purchasing Division
105 Municipal Way, Room 300
Juneau, AK 99801

MAILING ADDRESS:

City and Borough of Juneau, Purchasing Division
155 South Seward Street
Juneau, AK 99801

Please affix the label below to outer envelope in the lower left hand corner.

IMPORTANT NOTICE TO BIDDER		
To submit your Bid:		
1. Print your company name and address on the upper left corner of your envelope.		
2. Complete this label and place it on the lower left corner of your envelope.		
S E A L E D	BID NUMBER: <u>BE17-033</u>	B I D
	SUBJECT: <u>CBJ HEADWORKS IMPROVEMENTS</u>	
	DEADLINE DATE: <u>PRIOR TO 2:00PM ALASKA TIME</u>	

Mailing/delivery times to Alaska may take longer than other areas of the U.S. Late bids will not be accepted and will be returned.

SITE OF WORK. The site of the WORK is The Mendenhall Valley Wastewater Treatment Plant, 2009 Radcliffe Road, and Juneau-Douglas Treatment Plant, 1540 Than Road, both in Juneau, Alaska.

BIDDING, CONTRACT, or TECHNICAL QUESTIONS. All communications relative to this WORK, prior to opening Bids, shall be directed to the following:

Greg Smith, Contract Administrator
CBJ Engineering Department, 3rd Floor, Marine View Center
Email: greg.smith@juneau.org
Telephone: (907) 586-0873
Fax: (907) 586-4530

SECTION 00030 NOTICE INVITING BIDS

DEADLINE FOR BIDDER QUESTIONS: All questions must be received by the Contract Administrator prior to close of business, **November 29, 2016.**

DBE GOAL. The Disadvantaged Business Enterprise goal for this project is 5.91%.

BID SECURITY. Each Bid shall be accompanied by a certified or cashier's check or Bid Bond, in the amount of 5% percent of the Bid, payable to the City and Borough of Juneau, Alaska, as a guarantee that the Bidder, if its Bid is accepted, will promptly execute the Agreement. A Bid shall not be considered unless one of the forms of Bidder's security is enclosed with it.

CONTRACTOR'S LICENSE. All contractors are required to have a current Alaska Contractor's License, prior to submitting a Bid, and a current Alaska Business License prior to award.

BID TO REMAIN OPEN. The Bidder shall guarantee the Bid for a period of 120 Days from the date of Bid opening. Any component of the Bid may be awarded anytime during the 120 Days.

OWNER'S RIGHTS RESERVED. The OWNER reserves the right to reject any or all Bids, to waive any informality in a Bid, and to make award to the lowest responsive, responsible Bidder as it may best serve the interests of the OWNER.

OWNER: City and Borough of Juneau

By: 
Greg Smith, Contract Administrator

12/1/16
Date

END OF SECTION

SECTION 00500 - AGREEMENT

THIS AGREEMENT is between THE CITY AND BOROUGH OF JUNEAU (hereinafter called OWNER) and _____ (hereinafter called CONTRACTOR) OWNER and CONTRACTOR, in consideration of the mutual covenants hereinafter set forth, agree as follows:

ARTICLE 1. WORK.

CONTRACTOR shall complete the WORK as specified or as indicated under the Bid Schedule of the OWNER's Bid Documents entitled **Contract No. BE17-033, CBJ Headworks Improvements.**

The WORK is generally described as follows:

Mendenhall Valley Wastewater Treatment Plant (MWWTP): The improvements to the headworks includes removal of one existing automatic screen and grinder system and one manual bar screen, the installation of two new perforated plate screens and screening washer/compactors including new electrical connections to the screens and compactors, dismantling and removing an oil/water separation tank, relocating an existing grit classifier clarifier and conveyor, and modifications to the piping in the influent pump station, painting of pipe, installation of gas alarms, and miscellaneous related WORK. Installation of the new screens will require construction sequencing to dismantle and replace existing 16-inch and 18-inch ductile iron pipe and new 24-inch process piping to make space for the new screens.

Juneau-Douglas Wastewater Treatment Plant (JDTP): The improvements to the headworks includes the installation of two new perforated plate automatic screens and screening washer/compactors including new electrical connections to the screens and compactors, construction of new concrete influent channels and piping to connect the new influent channels to existing piping, construction of a new building around the new channels and miscellaneous related WORK. Site grading includes the installation of two new catch basins, new storm drain lines, and asphalt restoration. Demolition includes the removal of the existing automatic screen and manual screen, removal of existing concrete steps, removal of a timber framed wall and soffit, and removal of electrical feeds to the existing screens. Construction sequencing will be required to maintain the existing headworks in operation while the new screens and channels are construction.

The WORK to be paid under this contract shall include the following: Total Bid as shown in Section 00310 - Bid Schedule.

ARTICLE 2. CONTRACT COMPLETION TIME.

The WORK shall be completed according to the following table:

<u>Work Description</u>	<u>Completion Date</u>
MWWTP	September 1, 2017
Influent Piping Replacement	10 days from approved start date.
JDTP	November 1, 2017

Influent piping replacement completion date: 10 days from approved bypass start date (bypass is allowed April 1 – May 31, 2017, contractor may not commence influent piping replacement until CBJ pump replacement project is completed)

SECTION 00500 - AGREEMENT

ARTICLE 3. DATE OF AGREEMENT

The date of this Agreement will be the date of the last signature on page three of this section.

ARTICLE 4. LIQUIDATED DAMAGES.

OWNER and the CONTRACTOR recognize that time is of the essence of this Agreement and that the OWNER will suffer financial loss if the WORK is not completed within the time specified in Article 2 herein, plus any extensions thereof allowed in accordance with Article 12 of the General Conditions. They also recognize the delays, expense, and difficulties involved in proving in a legal proceeding the actual damages suffered by the OWNER if the WORK is not completed on time. Accordingly, instead of requiring any such proof, the OWNER and the CONTRACTOR agree that as liquidated damages for delay (but not as a penalty) the CONTRACTOR shall pay the OWNER for each Day that expires after the completion time specified in Article 2 herein. The amount of liquidated damages specified below is agreed to be a reasonable estimate based on all facts known as of the date of this Agreement.

<u>Work Description</u>	<u>Completion Date</u>	<u>Liquidated Damages</u>
MWWTP	September 1, 2017	\$650
Influent Piping Replacement	10 day from approved Start date	\$4,350
JDTP	November 1, 2017	\$650

ARTICLE 5. CONTRACT PRICE.

OWNER shall pay CONTRACTOR for completion of the WORK in accordance with the Contract Documents in the amount set forth in the Bid Schedule. The CONTRACTOR agrees to accept as full and complete payment for all WORK to be done in this contract for: **Contract No. BE17-033, CBJ Headworks Improvements**, those Lump Sum amounts as set forth in the Bid Schedule in the Contract Documents for this Project.

The total amount of this contract shall be _____ (\$ _____),
except as adjusted in accordance with the provisions of the Bid Documents.

ARTICLE 6. PAYMENT PROCEDURES.

CONTRACTOR shall submit Applications for Payment in accordance with Article 14 of the General Conditions. Applications for Payment will be processed by the ENGINEER as provided in the General Conditions.

Progress payments will be paid in full in accordance with Article 14 of the General Conditions until ninety (90) percent of the Contract Price has been paid. The remaining ten (10) percent of the Contract Price may be retained, in accordance with applicable Alaska State Statutes, until final inspection, completion, and acceptance of the Project by the OWNER.

ARTICLE 7. CONTRACT DOCUMENTS.

The Contract Documents which comprise the entire Agreement between OWNER and CONTRACTOR concerning the WORK consist of this Agreement (pages 00500-1 to 00500-6, inclusive) and the following sections of the Contract Documents:

SECTION 00500 - AGREEMENT

- Table of Contents (pages 00005-1 to 00005-3, inclusive)
- Notice Inviting Bids (pages 00030-1 to 00030-3, inclusive).
- Instructions to Bidders (pages 00100-1 to 00100-9, inclusive).
- Bid (pages 00300-1 to 00300-3, inclusive).
- Bid Schedule (pages 00310-1, inclusive).
- Bid Bond (page 00320-1, inclusive) or Bid Security.
- Subcontractor Report (pages 00360-1 to 00360-2, inclusive).
- DBE and EEO Documents (Section 00400 – Section 00480, inclusive)
- Performance Bond (pages 00610-1 to 00610-2, inclusive).
- Payment Bond (pages 00620-1 to 00620-2, inclusive).
- Insurance Certificate(s).
- General Conditions (pages 00700-1 to 00700-47, inclusive).
- Supplementary General Conditions (pages 00800-1 to 00800-6, inclusive).
- Alaska Labor Standards, Reporting, and Prevailing Wage Determination (page 00830-1).
- Technical Specifications as listed in the Table of Contents.
- Standard Specifications for Civil Engineering Projects and Subdivision Improvements, with 14 errata.
- Drawings consisting of 61 sheets, as listed in the Table of Contents.
- Addenda numbers ____ to ____, inclusive.
- Change Orders which may be delivered or issued after the Date of the Agreement and which are not attached hereto.

There are no Contract Documents other than those listed in this Article 7. The Contract Documents may only be amended by Change Order as provided in Paragraph 3.3 of the General Conditions.

ARTICLE 8. MISCELLANEOUS.

Terms used in this Agreement which are defined in Article 1 of the General Conditions will have the meanings indicated in the General Conditions.

No assignment by a party hereto of any rights under or interests in the Contract Documents will be binding on another party hereto without the written consent of the party sought to be bound; and specifically but without limitation monies that may become due and monies that are due may not be assigned without such consent (except to the extent that the effect of this restriction may be limited by law), and unless specifically stated to the contrary in any written consent to an assignment, no assignment will release or discharge the assignor from any duty or responsibility under the Contract Documents.

OWNER and CONTRACTOR each binds itself, its partners, successors, assigns and legal representatives to the other party hereto, its partners, successors, assigns and legal representatives in respect of all covenants, agreements and obligations contained in the Contract Documents. This Agreement shall be governed by the laws of the State of Alaska. Jurisdiction shall be in the State of Alaska, First Judicial District.

SECTION 00500 - AGREEMENT

IN WITNESS WHEREOF, OWNER and CONTRACTOR have caused this Agreement to be executed on the date listed below by OWNER.

OWNER:

CONTRACTOR:

City and Borough of Juneau

(Company Name)

(Signature)

(Signature)

By: Duncan Rorie Watt, City & Borough Manager
(Printed Name)

By: _____
(Printed Name, Authority or Title)

Date: _____

CONTRACTOR Signature Date: _____

OWNER's address for giving notices:

CONTRACTOR's address for giving notices:

155 South Seward Street

Juneau, Alaska 99801

907-586-0873 907-586-4530
(Telephone) (Fax)

(Telephone) (Fax)

(E-mail address)

Contractor License No. _____

SECTION 00500 - AGREEMENT

**CERTIFICATE
(if Corporation)**

STATE OF)
) SS:
COUNTY OF)

I HEREBY CERTIFY that a meeting of the Board of Directors of the
_____ a corporation existing under the laws of
the State of _____, held on _____, 20____, the following resolution
was duly passed and adopted:

“RESOLVED, that _____, as _____ President
of the Corporation, be and is hereby authorized to **execute the Agreement** with the CITY AND
BOROUGH OF JUNEAU and this corporation and that the execution thereof, attested by the
Secretary of the Corporation, and with the Corporate Seal affixed, shall be the official act and deed
of this Corporation.”

I further certify that said resolution is now in full force and effect.

IN WITNESS WHEREOF, I have hereunto set my hand and affixed the official seal of the
corporation this _____ day of _____, 20_____.

Secretary

(SEAL)

SECTION 00500 - AGREEMENT

CERTIFICATE
(if Partnership)

STATE OF)
) SS:
COUNTY OF)

I HEREBY CERTIFY that a meeting of the Partners of the _____ a partnership existing under the laws of the State of _____, held on _____, 20____, the following resolution was duly passed and adopted:

"RESOLVED, that _____, as _____ of the Partnership, be and is hereby authorized to **execute the Agreement** with the CITY AND BOROUGH OF JUNEAU and this partnership and that the execution thereof, attested by the _____ shall be the official act and deed of this Partnership."

I further certify that said resolution is now in full force and effect.

IN WITNESS WHEREOF, I have hereunto set my hand this _____, day of _____, 20_____.

Secretary

(SEAL)

SECTION 00500 - AGREEMENT

**CERTIFICATE
(if Joint Venture)**

STATE OF)
) SS:
COUNTY OF)

I HEREBY CERTIFY that a meeting of the Principals of the

_____ a joint venture existing under the laws of the

State of _____, held on _____, 20____, the following resolution was duly passed and adopted:

"RESOLVED, that _____, as _____ of the Joint Venture, be and is hereby authorized to **execute the Agreement** with the CITY AND BOROUGH OF JUNEAU and this joint venture and that the execution thereof, attested by the _____ shall be the official act and deed of this Joint Venture."

I further certify that said resolution is now in full force and effect.

IN WITNESS WHEREOF, I have hereunto set my hand this _____, day of _____, 20____.

Secretary

(SEAL)

END OF SECTION

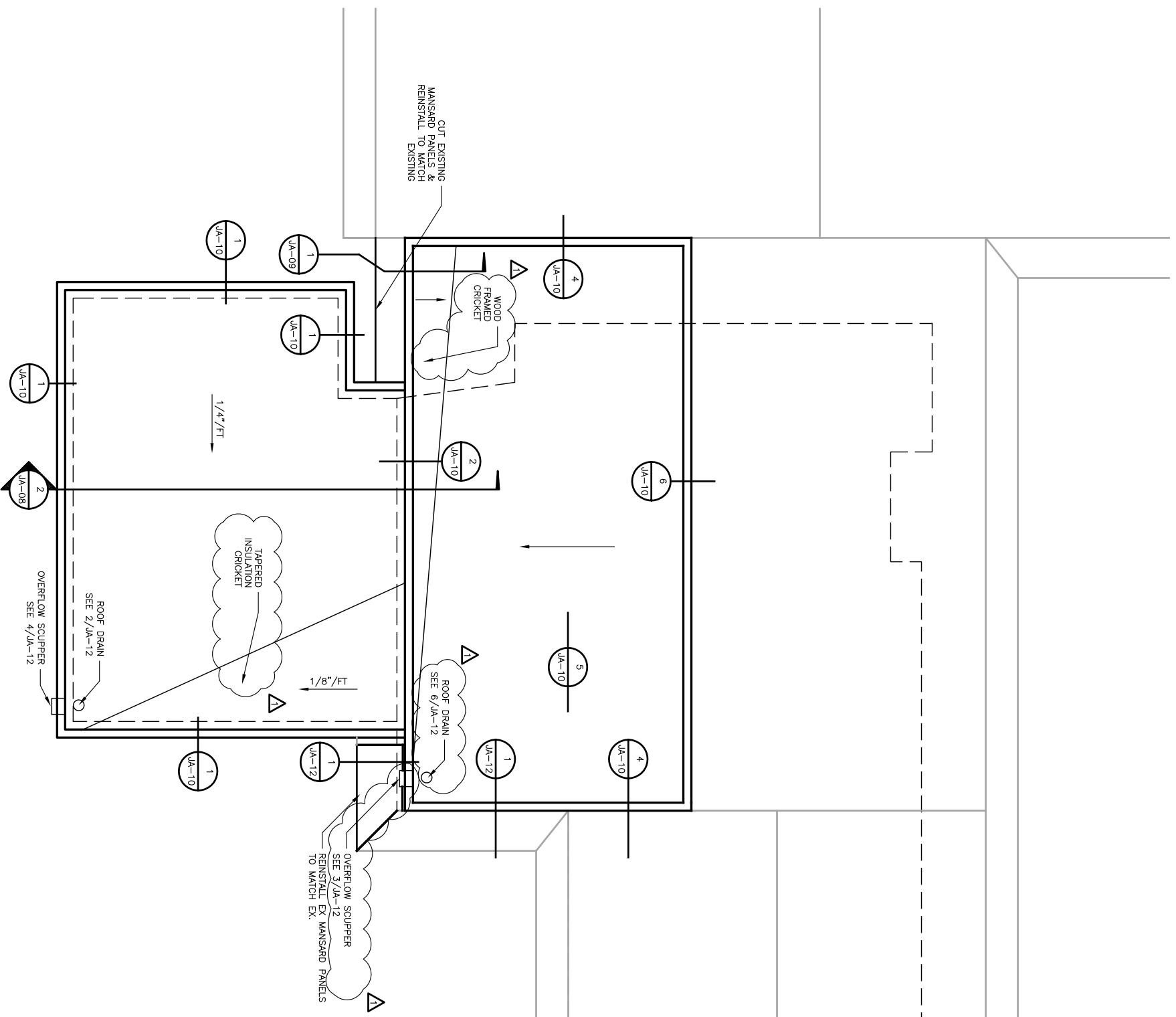

1 ROOF PLAN

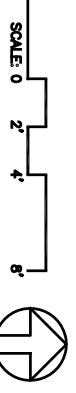

DOOR AND RELITE SCHEDULE								
OPENING No.	Type	Size	DOOR	FRAME	RATING	DETAILS	HW	REMARKS
101	A	3'-0" x 7'-2"	Met. Fin. Insul. Fin. E.G. PF	Met. Fin. Insul. Fin. E.G. PF		Head 1/0A-11 Sill 2/0A-11		
102	B	8'-0" x 6'-0"	STL	STL		5/0A-11 4/0A-11		

ABBREVIATIONS:
 HW HARDWARE
 FG FIBERGLASS
 PF PREFINISHED

REVISIONS			
REV	DATE	DESCRIPTION	BY
1	11/30/16	ADDENDUM 1	BW

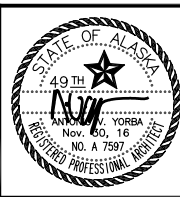

DOWL
 WWW.DOWL.COM
 5368 Commercial Boulevard
 Juneau, Alaska 99801
 907-780-3533

CBJ HEADWORKS IMPROVEMENTS
 CONTRACT No. BE17-033
JUNEAU DOUGLAS ARCHITECTURAL
 ROOF PLAN

PROJECT 4029/21157/01
 DATE 10/24/2016
 SHEET 46 OF 61
JA-05

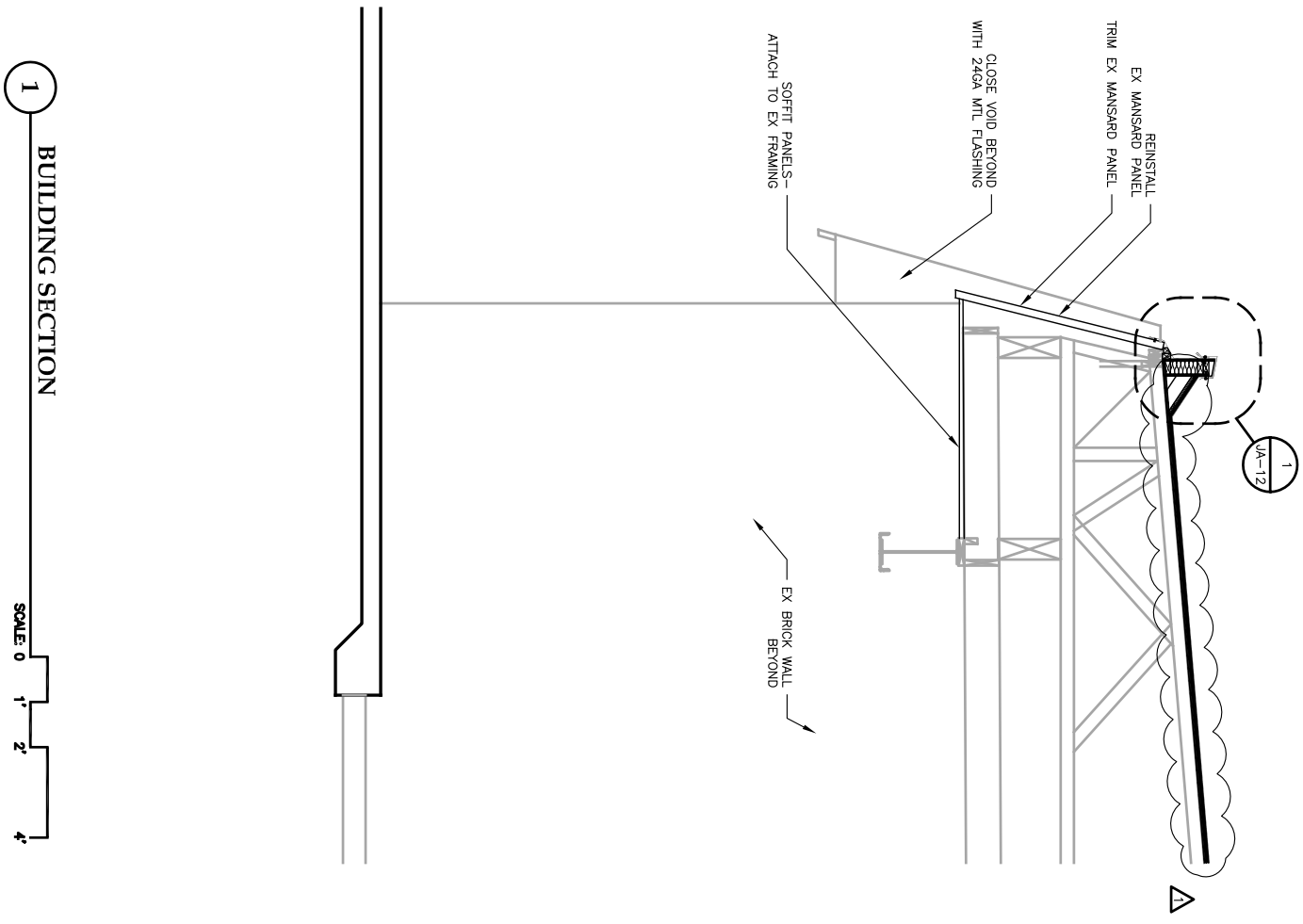

CBJ HEADWORKS IMPROVEMENTS
 CONTRACT No. BE17-033
JUNEAU DOUGLAS ARCHITECTURAL
 BUILDING SECTIONS



DOWL
 WWW.DOWL.COM
 5368 Commercial Boulevard
 Juneau, Alaska 99801
 907-780-3533

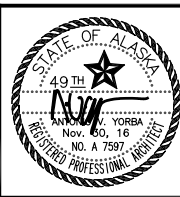

REVISIONS			
REV	DATE	DESCRIPTION	BY
1	11/30/16	ADDENDUM 1	BW

PROJECT 4029/21157/01
 DATE 10/24/2016
 SHEET 50 OF 61
JA-09

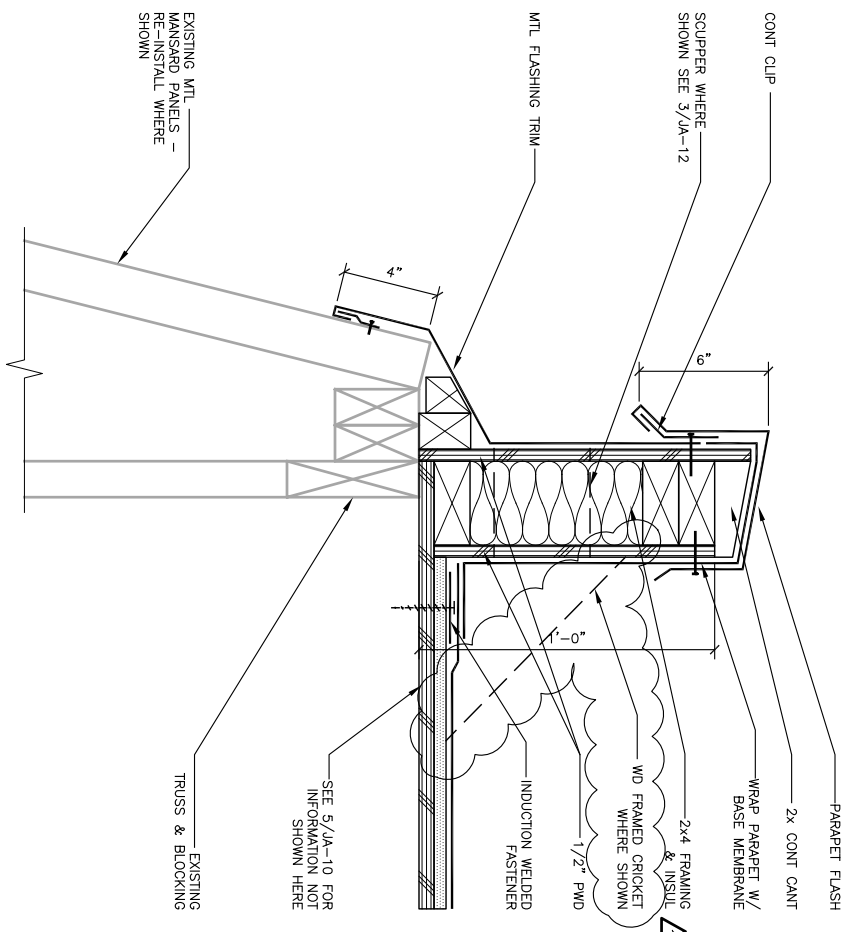

1 PARAPET
16016 - AB03/1

SCALE: 0 3" 6" 1'

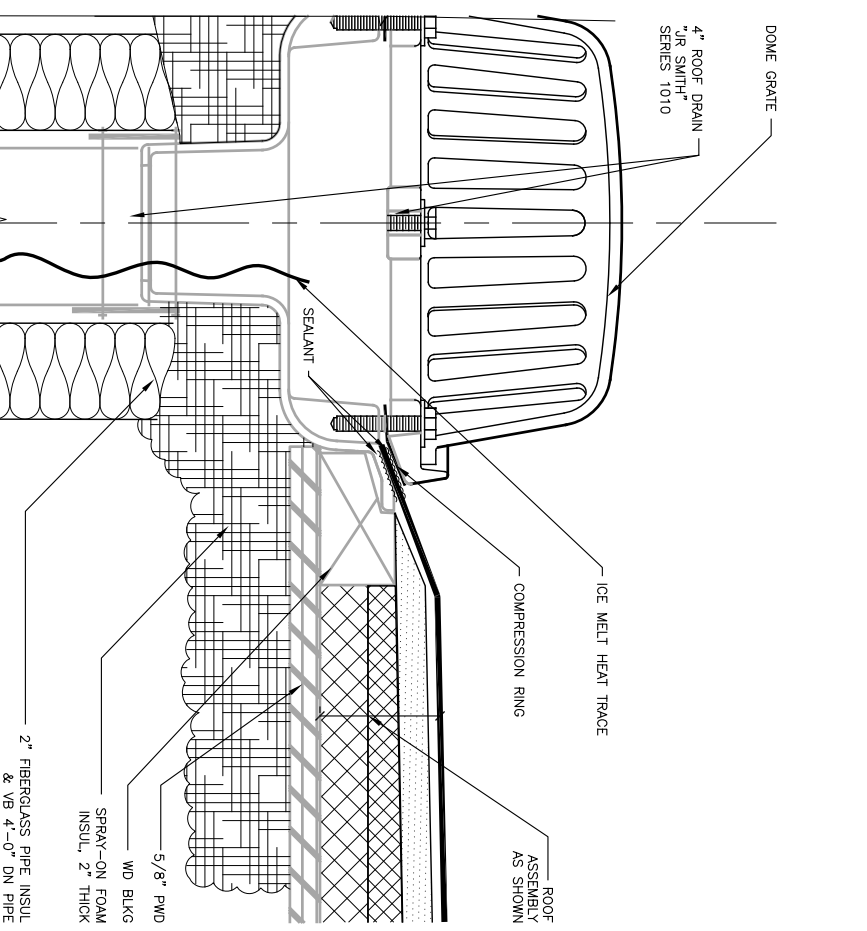

2 ROOF DRAIN DETAIL
16016/X-AB03-2

SCALE: 0 3" 6"

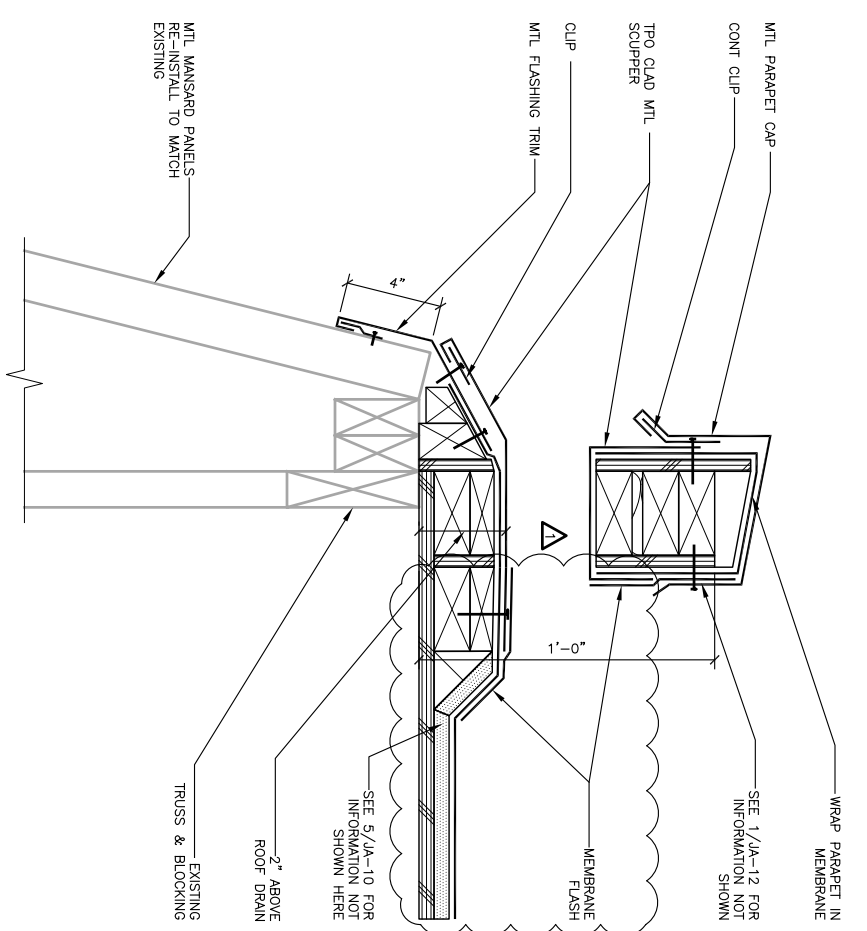

3 OVERFLOW SCUPPER
16016 - AB03/3

SCALE: 0 3" 6" 1'

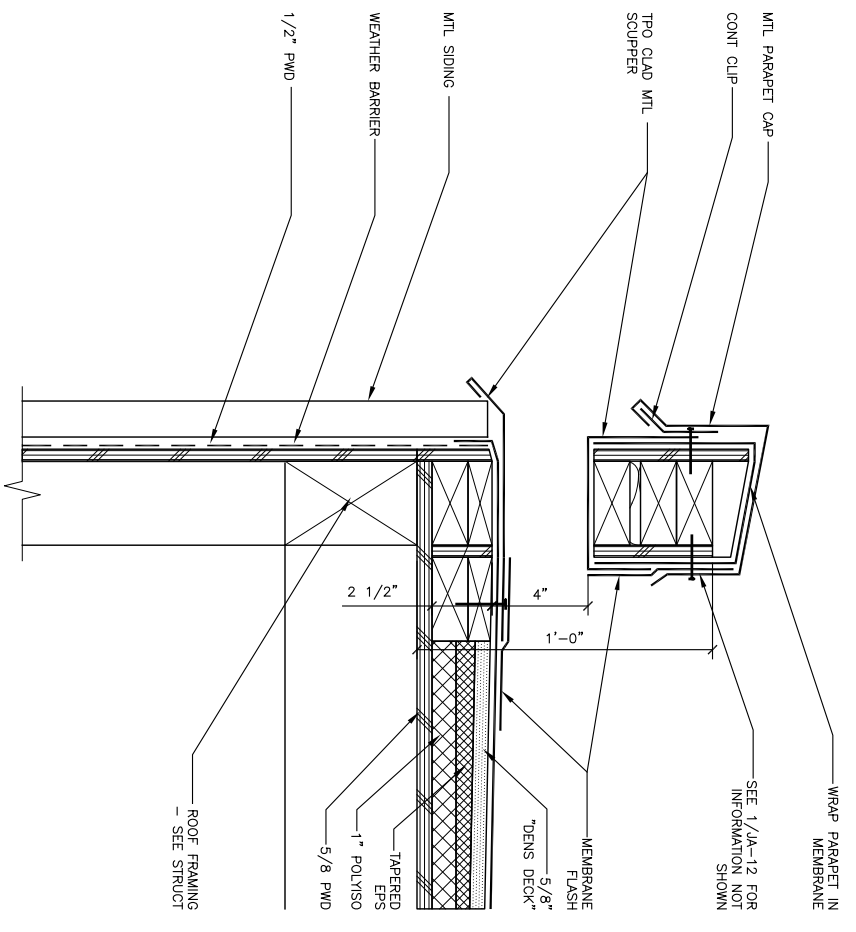

4 OVERFLOW SCUPPER
16016 - AB03/4

SCALE: 0 3" 6" 1'

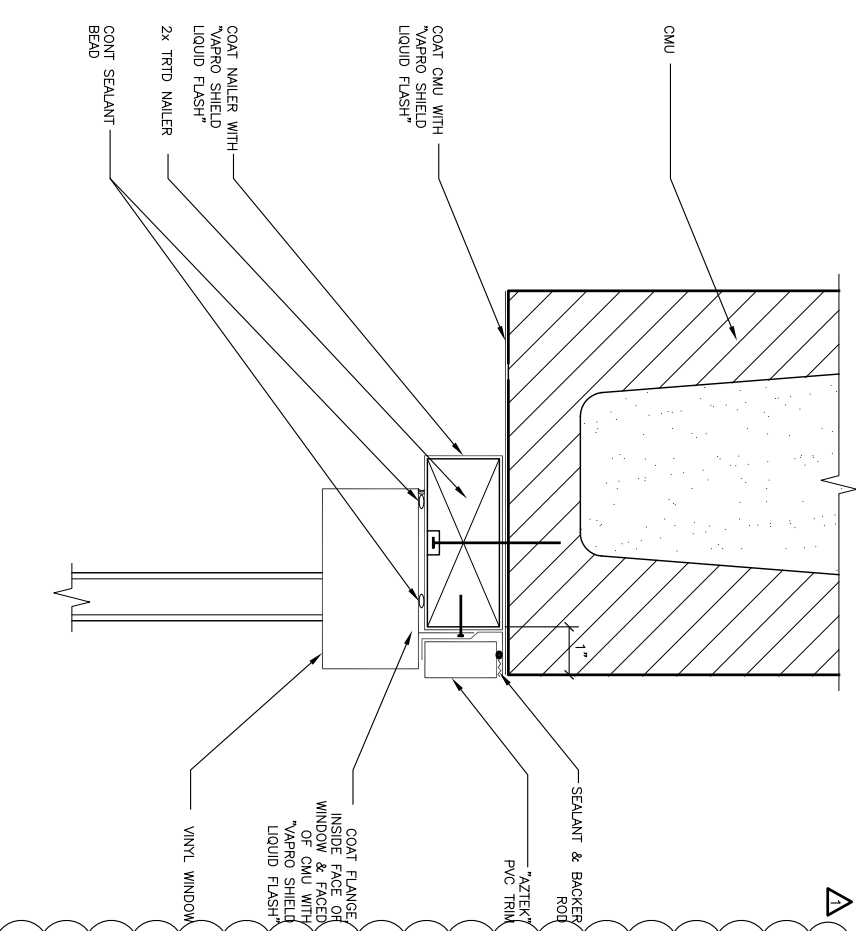

5 WINDOW HEAD, JAMB, SILL (SIM)
16016/X-AB03-5

SCALE: 0 3" 6"

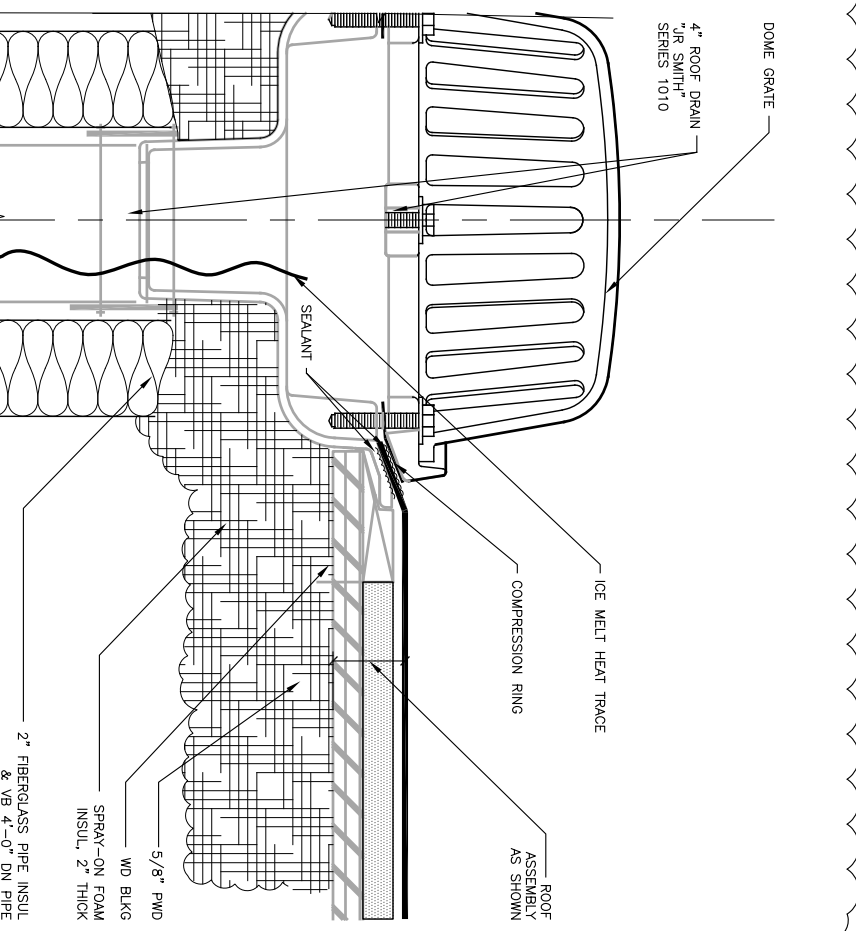

6 ROOF DRAIN DETAIL
16016/X-AB03-6

SCALE: 0 3" 6"

REV	DATE	DESCRIPTION	BY
1	11/30/16	ADDENDUM 1	BW

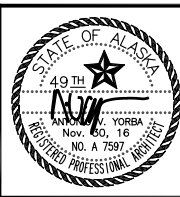

DOWL
WWW.DOWL.COM
5368 Commercial Boulevard
Juneau, Alaska 99801
907-780-3533

CBJ HEADWORKS IMPROVEMENTS
CONTRACT No. BE17-033
JUNEAU DOUGLAS ARCHITECTURAL
EXTERIOR DETAILS
PROJECT 4029/21157/01
DATE 10/24/2016
SHEET 53 OF 61
JA-12