

BASE CABINETS

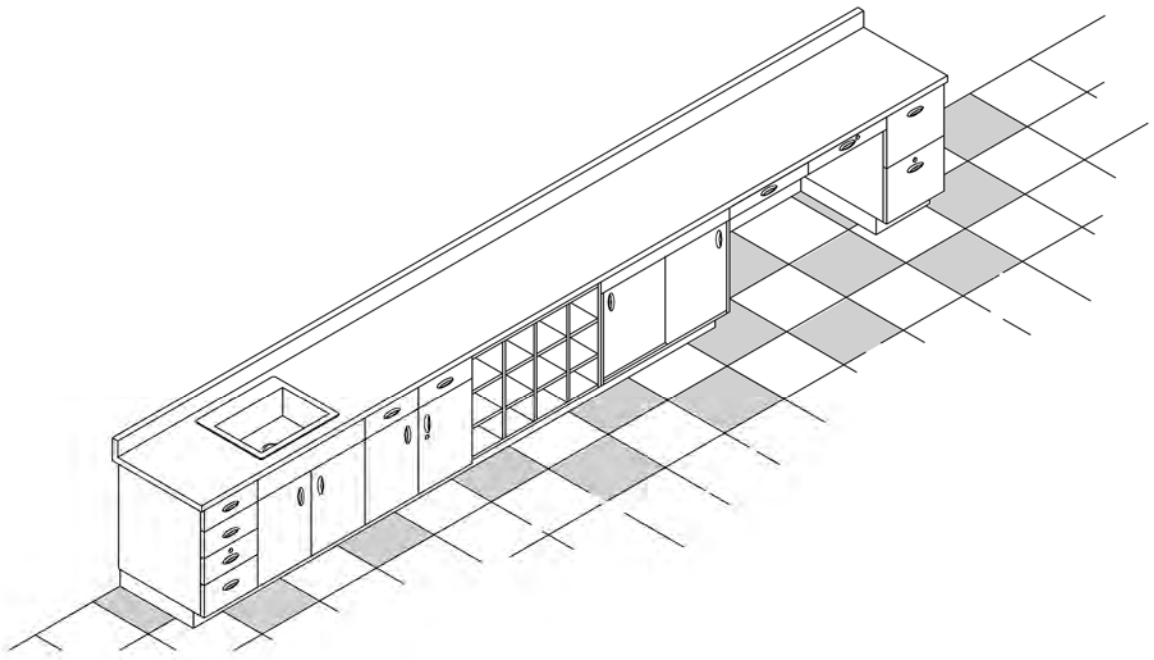

Base Cabinets

- Books
- Papers
- Kitchen equipment
- Open storage cabinets
- Drawer cabinets
- Cabinets with swinging doors
- Cabinets with sliding doors
- File drawers for both legal and letter files
- Corner cabinets

BASE CABINETS

- Base cabinets are available on 1" increments in width and depth.
- Base cabinets are 35 3/4" high for standing counters and 29 1/2" high for sitting counters. See the Module Table (Page 1.10) for other cabinet heights available. (Height from Module Table + 1 1/2" countertop thickness + 4" base = finish countertop height)
- Cabinet interiors on both open and closed units are available in almond, folkstone grey and white melamine.
- Exposed exterior colors for cabinets are selected from plastic laminate colors offered by Wilsonart, Formica, Pionite and Nevamar. (Premium priced laminates are subject to additional charges.)
- Adjustable shelves are 3/4" thick in cabinets up to 32" wide and 1" thick in cabinets wider than 32". Specify quantity of shelves required.
- Four shelf supports are provided for shelves up to 29" deep. Six shelf supports are provided for shelves 30" deep and over.
- Specific drawer requirements should be noted to insure adequate sizing.
- Single cabinet doors must have right or left hinge specified.
- Standard cabinet locks are the dead bolt type. They are keyed alike per room, different between rooms, and master keyed. Other key choices available upon request.
- See cabinet specifications for more information.

OPEN

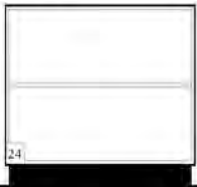

B100

Adjustable shelves

CUBICLES

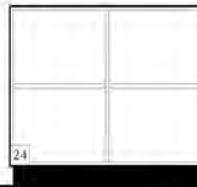

B111

Adjustable shelves
(1) 3/4" partition

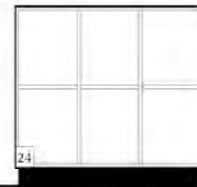

B112

Adjustable shelves
(2) 3/4" partitions

DOUBLE FACED OPEN



B113

Adjustable shelves
(3) 3/4" partitions

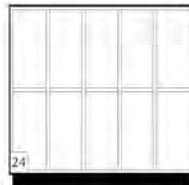

B114

Adjustable shelves
(4) 3/4" partitions

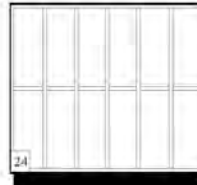

B115

Adjustable shelves
(5) 3/4" partitions

DOUBLE FACED OPEN

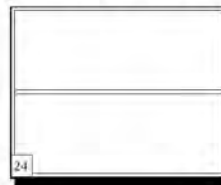

B120

Adjustable shelves

Section



B120D

Adjustable shelves
(1) 3/4" back divider

Section



OPEN

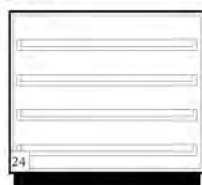

B170

Pullout shelves



B151

Adjustable shelves



B152

Adjustable shelves

BASE CABINETS

HINGED DOORS

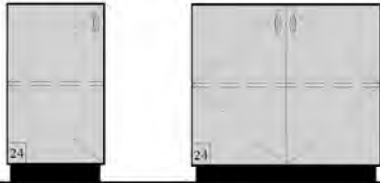

B201

Adjustable shelves

B202

Adjustable shelves

CUBICLES

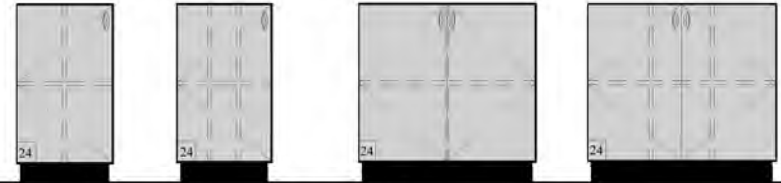

B209

Adjustable shelves
(1) 3/4" partition

B210

Adjustable shelves
(2) 3/4" partitions

B211

Adjustable shelves
(1) 3/4" partition

B212

Adjustable shelves
(2) 3/4" partitions

CUBICLES

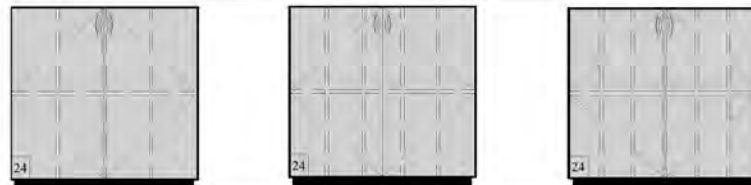

B213

Adjustable shelves
(3) 3/4" partitions

B214

Adjustable shelves
(4) 3/4" partitions

B215

Adjustable shelves
(5) 3/4" partitions

HINGED DOUBLE FACED

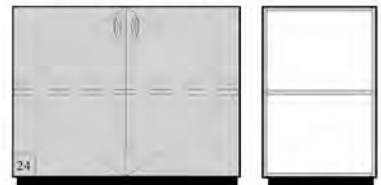

B220

Adjustable shelves

B220D

Adjustable shelves
(1) 3/4" back divider

Section

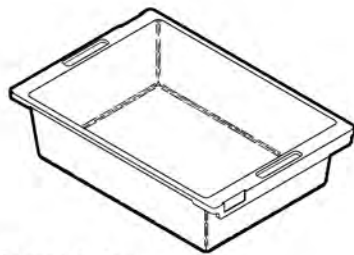

Large tote tray

13 7/8"W x 4 5/16"H x 19 7/8"D
TH490

Totemate® trays

One piece molded structural foam polypropylene plastic with handle and label holder at each end. Trays are available in either folkstone grey or almond color.

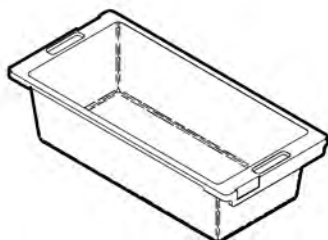

Small tote tray

10"W x 4 5/16"H x 19 7/8"D
TH491

LARGE TOTE TRAY STORAGE

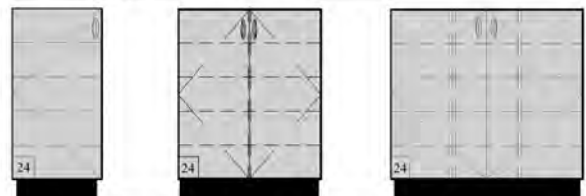

B260

16" Wide
1/2" Adjustable shelves
5 Large trays

B261

32" Wide
(1) 3/4" Vertical partitions
1/2" Adjustable shelves
10 Large trays

B262

48" Wide
(2) 3/4" Vertical partitions
1/2" Adjustable shelves
15 Large trays

SMALL TOTE TRAY STORAGE



B263

24" Wide
(1) 3/4" Vertical partition
1/2" Adjustable shelves
10 Small trays

B264

48" Wide
(3) 3/4" Vertical partitions
1/2" Adjustable shelves
20 Small trays

BLIND CORNER



B139

Adjustable shelves

B140

Adjustable shelves

B239

Adjustable shelves

B240

Adjustable shelves

BLIND CORNER



B141

Adjustable shelves

B142

Adjustable shelves

B641

Adjustable shelves

B642

Adjustable shelves

LAZY SUSAN CORNER STORAGE

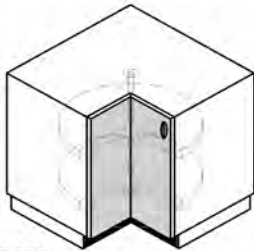

B275

(2) 28" Diameter adjustable kidney shelves
Continuous door hinges

B277

Adjustable shelves
(Rotating shelves omitted)

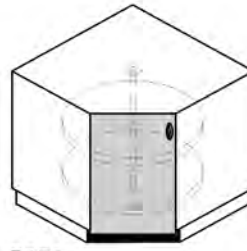
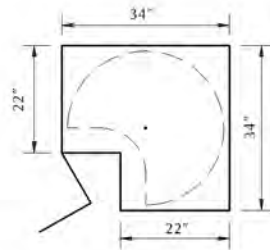

B276

(2) 24" Diameter adjustable full circle shelves

B278

Adjustable shelves
(Rotating shelves omitted)

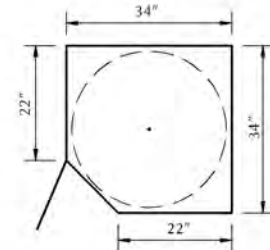

SINK BASE CORNER STORAGE

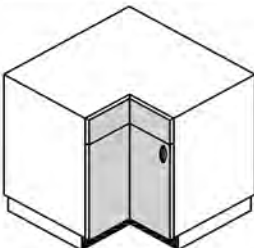

B279
Face rail

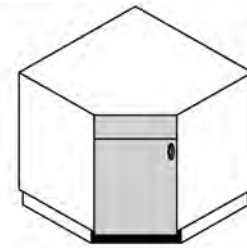
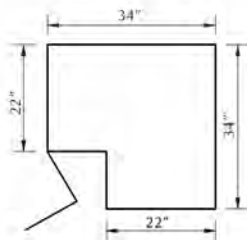

B280
Face rail

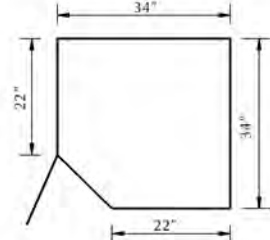

BASE CABINETS

OPEN SINK



B132

Adjustable shelves
optional

SINK HINGED DOORS



B234

Concealed rail
Subtop omitted

B235

Concealed rail
Subtop omitted

SLIDING DOOR SINK BASE

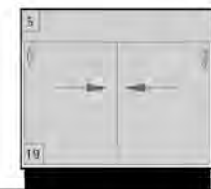

B432

Sliding doors
Face rail
Subtop omitted

SINK HINGED DOORS



B231

Face rail
Subtop omitted

B232

Face rail
Subtop omitted

B233

Face rail
Subtop omitted



SINK HINGED DOORS - NO BOTTOM

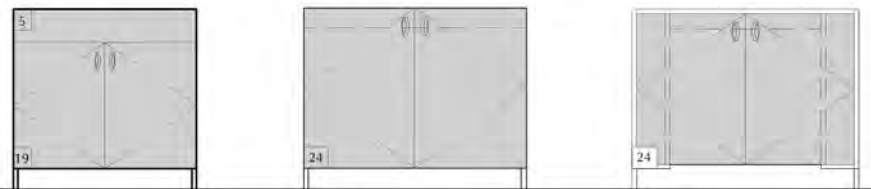

B236

Face rail
Wheelchair accessible
Subtop & bottom omitted

B238

Support rail behind doors
Wheelchair accessible
Subtop & bottom omitted

B230

Retractable (pocket) doors
Wheelchair accessible
Subtop & bottom omitted

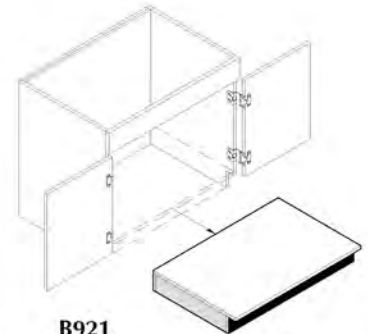

B921

Optional removable bottom with
attached toe kick.



SINK WALL HUNG

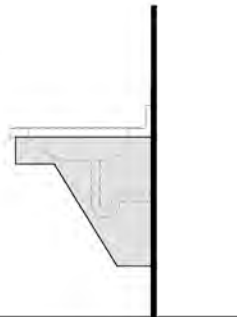

B237

Wheelchair accessible wall
hung sink enclosure

Side view of B237

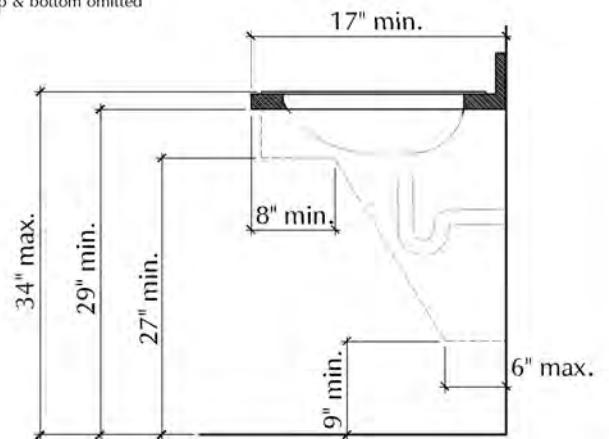

HINGED DOORS



B270
Pullout shelves

3/4" SLIDING

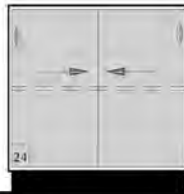

B402
Sliding doors
Adjustable shelves

DOUBLE FACED SLIDING

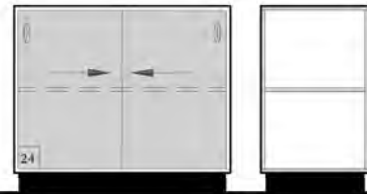

B420 Section
Sliding doors
Adjustable shelves
B420D
Sliding doors
Adjustable shelves
(1) 3/4" back divider

3/4" SLIDING DOOR

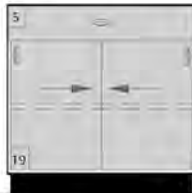

B451
Sliding doors
Adjustable shelves



B452
Sliding doors
Adjustable shelves

DOOR & DRAWER COMBINATION



B650
Adjustable shelves



B650P
Adjustable shelves
Pullboard



B651
Adjustable shelves



B652
Adjustable shelves

DOOR & DRAWER COMBINATION

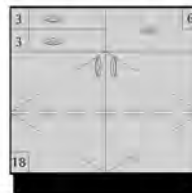

B654
Adjustable shelves

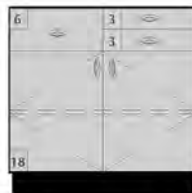

B655
Adjustable shelves



B656
Adjustable shelves

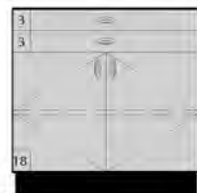

B657
Adjustable shelves

BASE CABINETS

LOCKER STORAGE

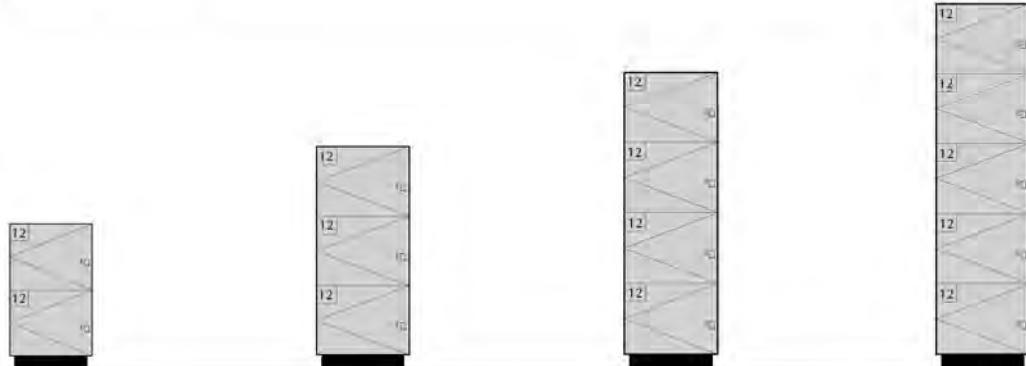

B942X
Key lock

B943X
Key lock

B944X
Key lock

B945X
Key lock

B942Z
Padlock hasp

B943Z
Padlock hasp

B944Z
Padlock hasp

B945Z
Padlock hasp

MULTI-DRAWER STORAGE



D701
(1) drawer

D702
(2) drawers

D703
(3) drawers

D704
(4) drawers

D705
(5) drawers

D706
(6) drawers

D707
(7) drawers

DRAWER STORAGE WITH PULLBOARD



D703P
(3) drawers
Pullboard

D704P
(4) drawers
Pullboard

RANGETOP WITH DRAWERS



D743
(3) drawers
Face rail

D744
(4) drawers
Face rail

PAPER STORAGE DRAWERS



D713
(3) drawers



D714
(4) drawers



D715
(5) drawers



D716
(6) drawers



D717
(7) drawers

Paper drawers are hooded and furnished with full extension guides

DOUBLE MULTI-DRAWER STORAGE

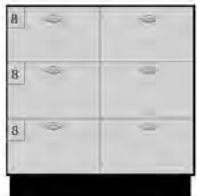

D723
(6) drawers



D724
(8) drawers



D725
(10) drawers



D726
(12) drawers



D727
(14) drawers

DRAWER COMBINATION



D730
(5) drawers



D731
(6) drawers



D732
(6) drawers

DRAWER COMBINATION



D733
(6) drawers



D734
(7) drawers



D735
(6) drawers

BASE CABINETS



FILE DRAWER STORAGE

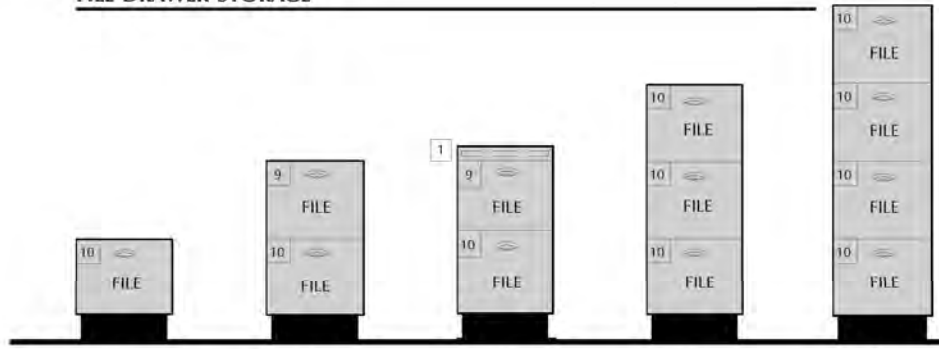

File Cabinet

Letter file 16" wide
 Legal file 19" wide
 Specify legal or letter

F801
(1) file

F802
(2) files

F802P
(2) files
Pullboard

F803
(3) files

F804
(4) files

FILE DRAWER STORAGE

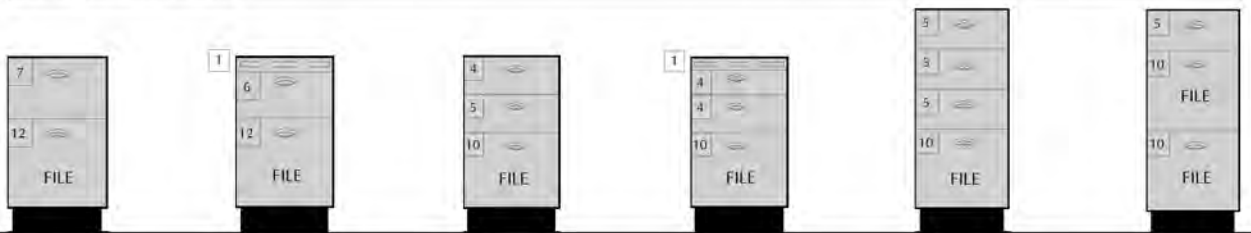

F812
(1) file
(1) box drawer

F812P
(1) file
(1) drawer
Pullboard

F813
(1) file
(2) drawers

F813P
(1) file
(2) drawers
Pullboard

F814
(1) file
(3) drawers

F823
(2) files
(1) drawer



LATERAL FILE DRAWER STORAGE

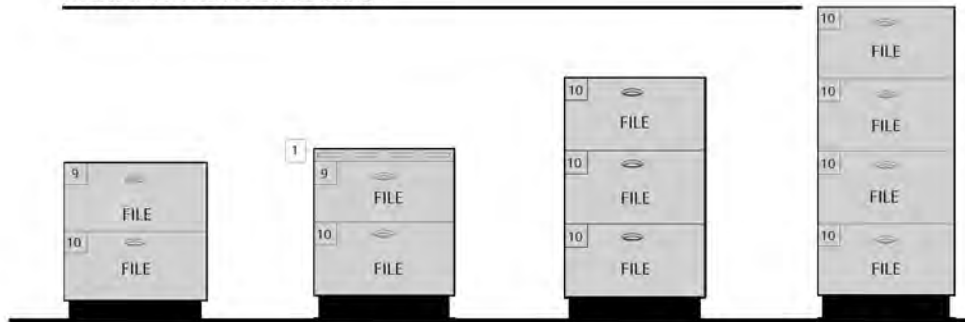

Lateral File Cabinet

Min. depth 20"
 Max. width 36"
 Legal and letter

F832
(2) files

F832P
(2) files
Pullboard

F833
(3) files

F834
(4) files

LATERAL FILE DRAWER STORAGE

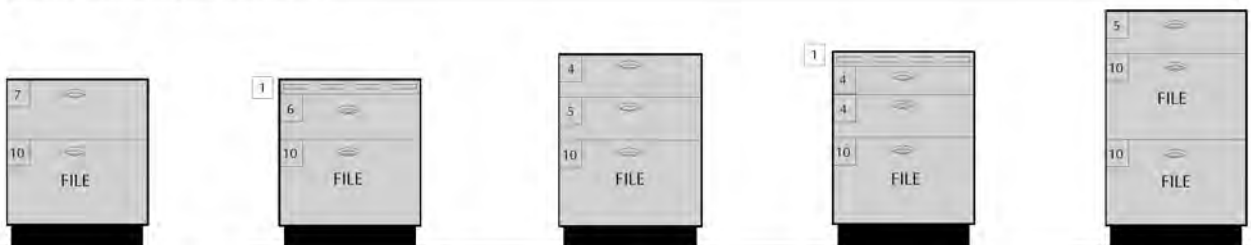

F842
(1) file
(1) drawer

F842P
(1) file
(1) drawer
Pullboard

F843
(1) file
(2) drawers

F843P
(1) file
(2) drawers
Pullboard

F853
(2) files
(1) drawer

UNDER COUNTER OPEN STORAGE (Min. height 3 3/4")

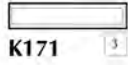

K171

3



K172

3



K173

3

FACE RAIL (Minimum height 3 3/4")

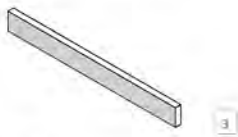

K57B

Length 96"
3mm PVC at bottom edge

3

KNEE SPACE DRAWERS (Min. height 3 3/4" - Inside clear height 2 3/4")



K771

3



K772

3



K773

3



K781

3



K782

3

PENCIL DRAWERS WITH GUIDES



K775

15"W x 3 3/4"H x 21"D
Molded plastic tray
Metal roller guides

3

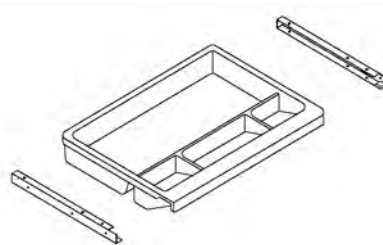

K776

21"W x 3 3/4"H x 16"D
Molded plastic tray
without front
Plastic guides

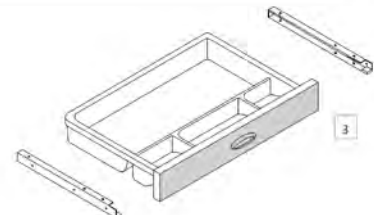

K777

21"W x 3 3/4"H x 16"D
Molded plastic tray
with front
Plastic guides

3

WALL CABINETS

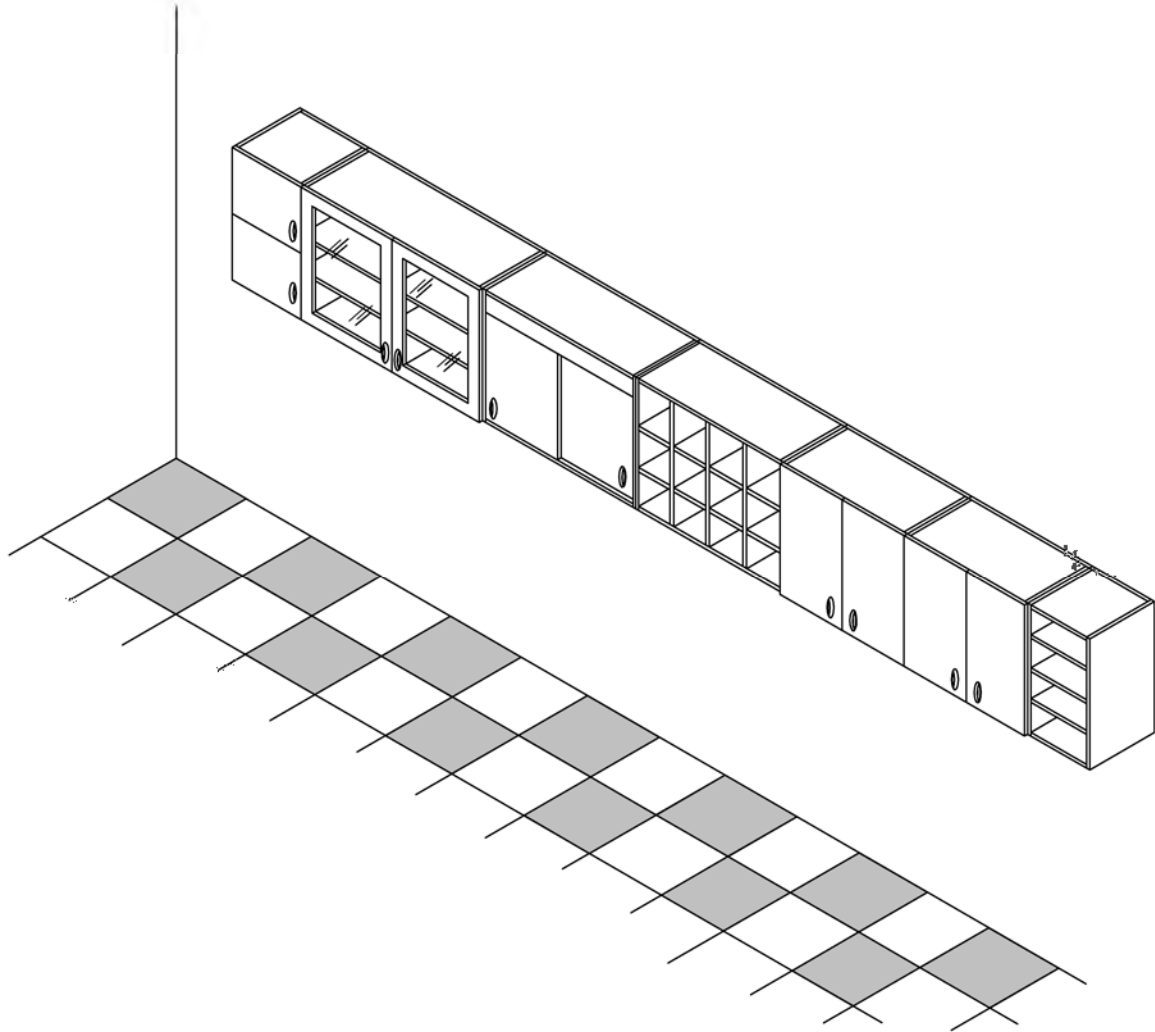

Wall Cabinets

- Open shelves
- Sliding and swinging door cabinets
- Cubicles
- Glass swinging and sliding door cabinets
- Corner cabinets with rotating shelves

WALL CABINETS

- Wall cabinets are available on 1" increments in width and depth.
- Wall cabinets are 30 1/4" high unless otherwise noted. See Module Table for other cabinet heights available (24 module = 30 1/4" high).
- Cabinet interiors at both open and closed units are available in almond, folkstone grey and white melamine.
- Exposed exterior colors for cabinets and countertops are selected from plastic laminate colors offered by Wilsonart, Formica, Pionite and Nevamar. Premium priced laminates are subject to additional charges.
- Adjustable shelves are 3/4" thick in cabinets up to 32" wide and 1" thick in cabinets wider than 32". Shelves over 42" wide are not recommended. Specify quantity of shelves required.
- Four shelf supports are provided for shelves up to 29" deep. Six shelf supports are provided for shelves 30" deep and over.
- Single cabinet doors must have right or left hinge specified.
- All glazing provided for cabinet doors is 1/4" thick plate glass unless otherwise specified. Fixed glass is installed with removable PVC stops.
- Standard cabinet locks are dead bolt type. They are keyed alike per room, different between rooms, and master keyed. Other key choices available upon request.
- Light valances can be provided at any upper cabinet by adding "V" to the model number. Standard valance height is 2 1/2" unless otherwise noted.
- See cabinet specifications for more information.

OPEN

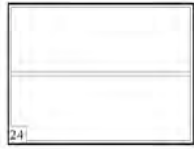

W100
Adjustable shelves

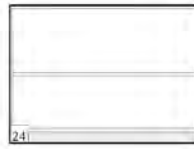

W100V
Adjustable shelves
2 1/2" Light valance

CUBICLES

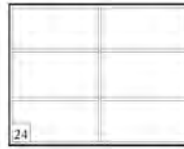

W111
Adjustable shelves
(1) 3/4" Partition

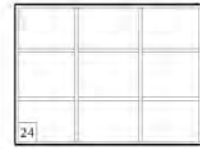

W112
Adjustable shelves
(2) 3/4" Partitions

CUBICLES

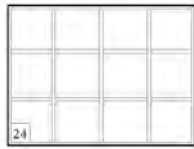

W113
Adjustable shelves
(3) 3/4" Partitions

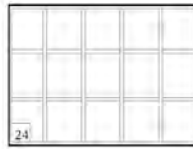

W114
Adjustable shelves
(4) 3/4" Partitions

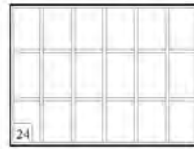

W115
Adjustable shelves
(5) 3/4" Partitions

OPEN DOUBLE FACED

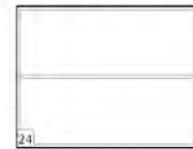

W120
Adjustable shelves

Section



OPEN DOUBLE FACED

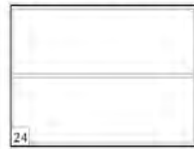

W120D
Adjustable shelves
(1) 3/4" Back divider

Section



W120V
Adjustable shelves
2 1/2" Light valance

Section



CUBICLES

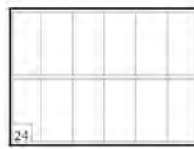

W131
1" Fixed shelf
1/2" Adjustable dividers
Specify quantity of dividers

WALL HUNG BOOKSHELF

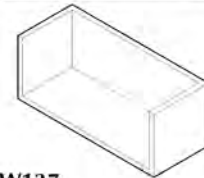

W137
12" High x 12" deep

OPEN WALL HUNG WARDROBE



W138R
Shelf with clothes rod under

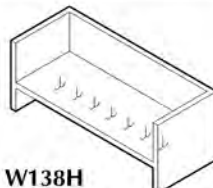

W138H
Shelf with coat hooks under

OPEN BLIND CORNER

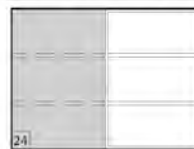

W139
Adjustable shelves



W140
Adjustable shelves

WALL CABINETS

HINGED DOORS



W201
Adjustable shelves



W201G
Stile & rail glass doors
Adjustable shelves



W201GV
Stile & rail glass doors
Adjustable shelves
2 1/2" Light valance



W201V
Adjustable shelves
2 1/2" Light valance

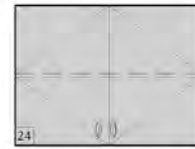

W202
Adjustable shelves

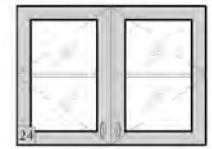

W202G
Stile & rail glass doors
Adjustable shelves

HINGED DOORS

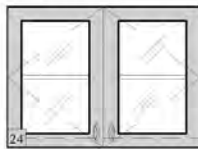

W202GV
Stile & rail glass doors
Adjustable shelves
2 1/2" Light valance



W202V
Adjustable shelves
2 1/2" Light valance

HINGED DOOR CUBICLES



W209
Adjustable shelves
(1) 3/4" Partition



W210
Adjustable shelves
(2) 3/4" Partitions

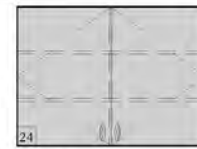

W211
Adjustable shelves (1)
(1) 3/4" Partition

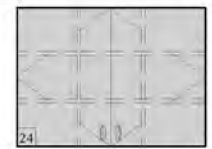

W212
Adjustable shelves (2)
(2) 3/4" Partitions

HINGED DOOR CUBICLES

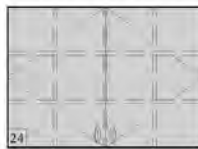

W213
Adjustable shelves
(3) 3/4" Partitions

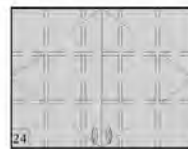

W214
Adjustable shelves (4)
(4) 3/4" Partitions

DOUBLE FACED HINGED DOORS



W219
Adjustable shelves



Section



W219V
Adjustable shelves
2 1/2" Light valance



Section

W219D

Adjustable shelves
(1) 3/4" Back divider

DOUBLE FACED HINGED DOORS



W220
Adjustable shelves

W220D

Adjustable shelves
(1) 3/4" Back divider



Section



W220V
Adjustable shelves
2 1/2" Light valance



Section

HINGED DOOR CUBICLE

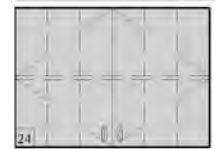

W231
1" Fixed shelf
1/2" Adjustable dividers
Specify quantity of dividers

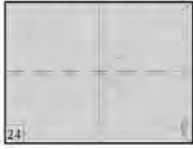
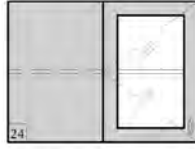
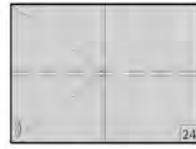
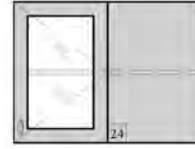
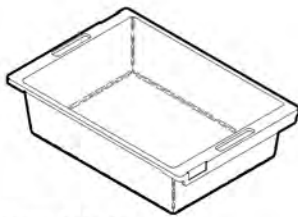
BLIND CORNER

W239
 Adjustable shelves

W239G
 Stile and rail glass door
 Adjustable shelves

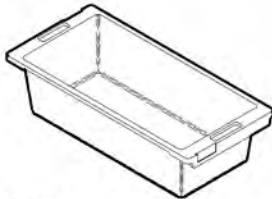
W240
 Adjustable shelves

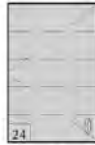
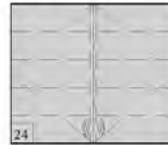
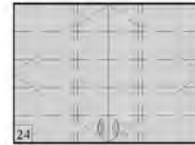
W240G
 Stile and rail glass door
 Adjustable shelves

Large Tote Tray
 13 7/8"W x 4 5/16"H x 19 7/8"D
 TH490

Totemate® trays

One piece molded structural foam polypropylene plastic with handle and label holder at each end. Trays are available in either folkstone grey or almond color.



Small Tote Tray
 10"W x 4 5/16"H x 19 7/8"D
 TH491

LARGE TOTE TRAY STORAGE

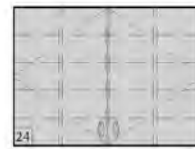
W260
 16" Wide
 22" Min. depth
 1/2" Adjustable shelves
 5 Large trays

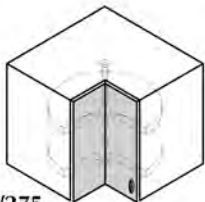
W261
 32" Wide
 22" Min. depth
 (1) 3/4" Vertical partition
 1/2" Adjustable shelves
 10 Large trays

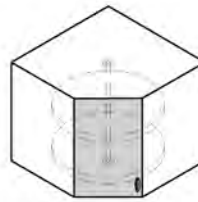
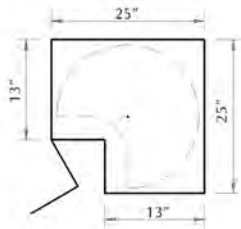
W262
 48" Wide
 22" Min. depth
 (2) 3/4" Vertical partition
 1/2" Adjustable shelves
 15 Large trays

SMALL TOTE TRAY STORAGE

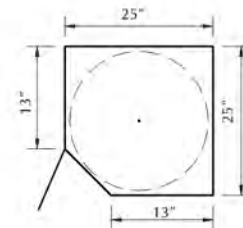
W263
 24" Wide
 22" Min. depth
 (1) 3/4" Vertical partition
 1/2" Adjustable shelves
 10 Small trays

W264
 48" Wide
 22" Min. depth
 (3) 3/4" Vertical partition
 1/2" Adjustable shelves
 20 Small trays

LAZY SUSAN CORNER STORAGE

W275
 (2) 18" Diameter adjustable kidney shelves
 Continuous hinge between doors

W277
 Adjustable shelves
 (rotating shelves omitted)

W276
 (2) 18" Diameter adjustable full circle shelves

W278
 Adjustable shelves
 (rotating shelves omitted)

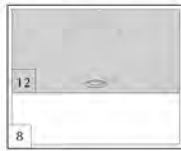
WALL CABINETS

HINGED DOORS



W298
16" Min. depth



W299
16" Min. depth



W301
Adjustable shelves

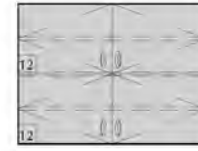

W302
Adjustable shelves



W346
Adjustable shelves

HINGED DOOR & SHELF COMBINATIONS

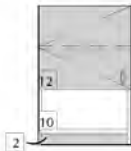

W346V
Adjustable shelves
2 1/2" Light valance

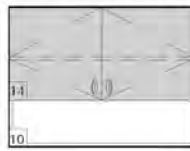

W347
Adjustable shelves

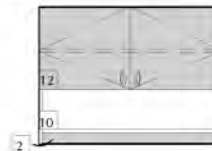

W347V
Adjustable shelves
2 1/2" Light valance



W348
Adjustable shelves
1/2" adjustable dividers

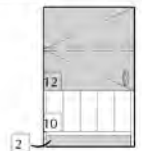

W348V
Adjustable shelves
1/2" adjustable dividers
2 1/2" Light valance

HINGED DOOR & SHELF COMBINATIONS

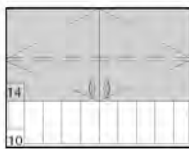

W349
Adjustable shelves
1/2" adjustable dividers

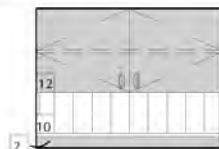

W349V
Adjustable shelves
1/2" adjustable dividers
2 1/2" Light valance

SLIDING DOORS

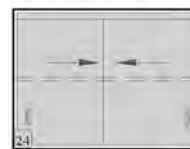

W402
Sliding doors
Adjustable shelves

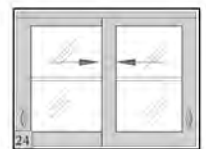

W402G
Sliding stile and rail glass doors
Adjustable shelves

SLIDING DOORS



W402V
Sliding doors
Adjustable shelves
2 1/2" Light valance

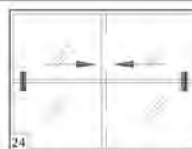

W404G
Sliding glass doors
Adjustable shelves



W411
Sliding doors
Adjustable shelves
(1) 3/4" Fixed partition

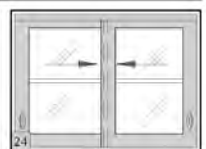

W411G
Sliding stile and rail glass doors
Adjustable shelves
(1) 3/4" Partition

WALL SHELVING SYSTEM

Wall shelves are supported by 12 gauge steel anochrome standards and support brackets.
 K&V #87 Standards, #187 Brackets

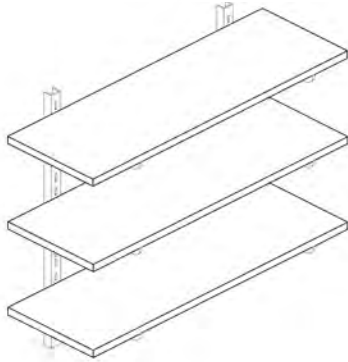

S123 Shown
42 36 12
 42" Max. width

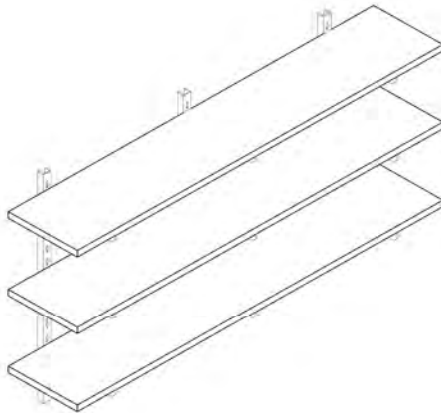

S133 Shown
96 36 12
 96" Max. width

<u>Catalog #</u>	<u>Description</u>
S121	24" standard with (1) shelf
S122	24" standard with (2) shelves
S123	36" standard with (3) shelves
S124	48" standard with (4) shelves
S125	60" standard with (5) shelves
S126	72" standard with (6) shelves
S127	84" standard with (7) shelves
S128	96" standard with (8) shelves

- Shelves are 1" thick overlaid with thermofused melamine. All four edges are banded with .018" PVC. Colors available are almond, folkstone grey, and white.
- Plastic laminate finish can be provided by adding the suffix "L" to the model number.
- Shelf lengths are available in 1" increments up to 42".
- Shelf depths available are 12", 14", 16", 18", 20", 22" and 24"

<u>Catalog #</u>	<u>Description</u>
S131	24" standard with (1) shelf
S132	24" standard with (2) shelves
S133	36" standard with (3) shelves
S134	48" standard with (4) shelves
S135	60" standard with (5) shelves
S136	72" standard with (6) shelves
S137	84" standard with (7) shelves
S138	96" standard with (8) shelves

- Shelves are 1" thick overlaid with thermofused melamine. All four edges are banded with .018" PVC. Colors available are almond, folkstone grey, and white.
- Plastic laminate finish can be provided by adding the suffix "L" to the model number.
- Shelf lengths are available in 1" increments up to 96".
- Shelf depths available are 12", 14", 16", 18", 20", 22" and 24"

MODERNFOLD™

A DORMA Group Company



Accordion Doors & Partitions

SOUNDMASTER® / MODERNFOLD

Accordion Doors and Partitions from Modernfold.

When you need to get the most from your space.

Accordion doors and partitions from Modernfold are designed to provide quick and easy space division with moderate sound attenuation and a pleasing visual appearance.

All Modernfold accordion doors and partitions provide quick sight and sound division with a simple pull-and-latch

operation. Electric operation is also available. Accordion doors and partitions are available as single and paired openings. For optimal design flexibility, curved track allows the partition to move around corners. Modernfold offers a large selection of standard finishes.

Since Modernfold's inception, building owners, facility managers, architects, interior designers, and contractors have come to recognize the Modernfold name—a name synonymous with flexible space design, quality products, professional installation, and ongoing product support.



Soundmaster®

For versatility and durability, Modernfold's Soundmaster offers a broad range of vinyl, carpet, and fabric choices to complement any room decor. Its steel sound liner and three-ply top and bottom sweeps provide moderate speech privacy.



Modernfold®

Modernfold accordion doors and partitions are the industry standard. With their durability, replaceable outer

coverings and easy operation, they are designed to give you many years of easy and trouble free operation.

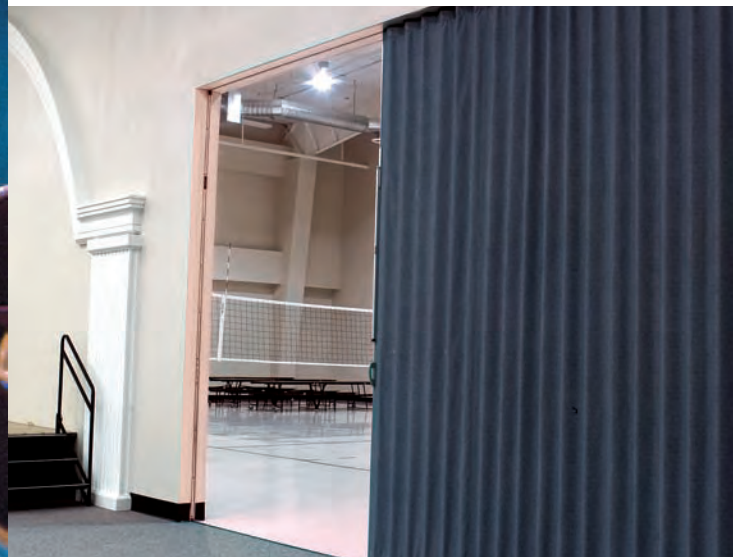

Soundmaster accordion partitions are ideal for dividing space economically when moderate sound attenuation is desired.

Soundmaster accordion partitions are ideal for applications in church classrooms, fellowship halls, clinics, restaurants, and many other applications. Behind its fabric outer covering, Soundmaster has steel paneled sound liners to provide moderate sound attenuation and increased durability. Optional electric

operation makes large, even curved openings as easy as turning a key. When both durability and moderate noise reduction are important, Soundmaster partitions are the answer.

Acoustical Performance—up to 40 STC is provided with Soundmaster's steel panel and

membrane liners. Three-ply top and bottom sweeps assure a positive seal. Long term strength and durability is made possible by Soundmaster's patented, three-dimensional welded steel frame and heavy duty construction.



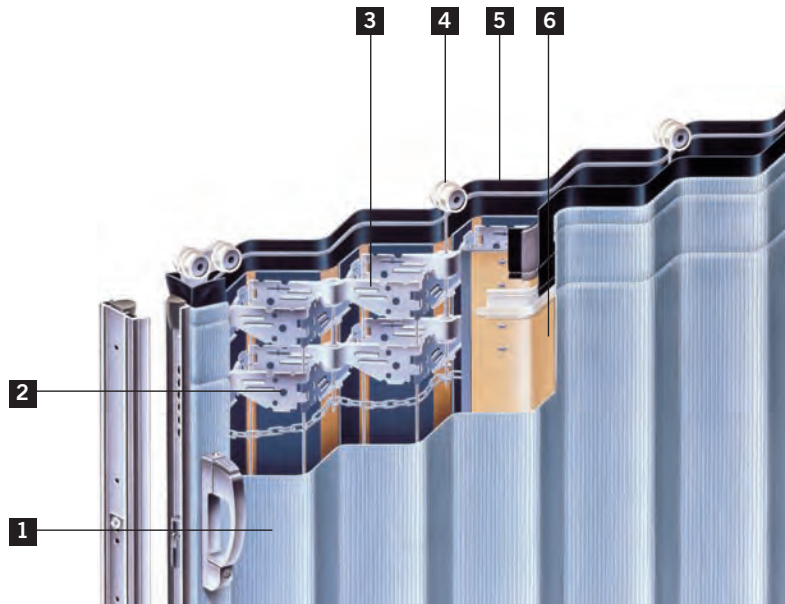

1 Easily replaceable
Class A rated coverings

2 Continuous horizontal
pantograph hinges

3 Three-dimensional
welded steel frame

4 Ball-bearing trolleys
with high tensile
yokes

5 Three-ply top and
bottom sweep seals

6 Steel sound liner



The Modernfold accordion is ideal for basic sight and space separation.

When strength and durability are important and only sight division is required, Modernfold accordion doors and partitions are the answer. Modernfold partitions feature a durable steel

frame construction, ball bearing trolleys, and a wide choice of finish options. The heavy, all steel frame and hinging, which supports the finish, takes a lot of abuse, yet its weight requires

only minimal support. In addition to simple, straight "wall-to-wall" runs, Modernfold accordion partitions can be curved or even serpentine to meet your exact needs.

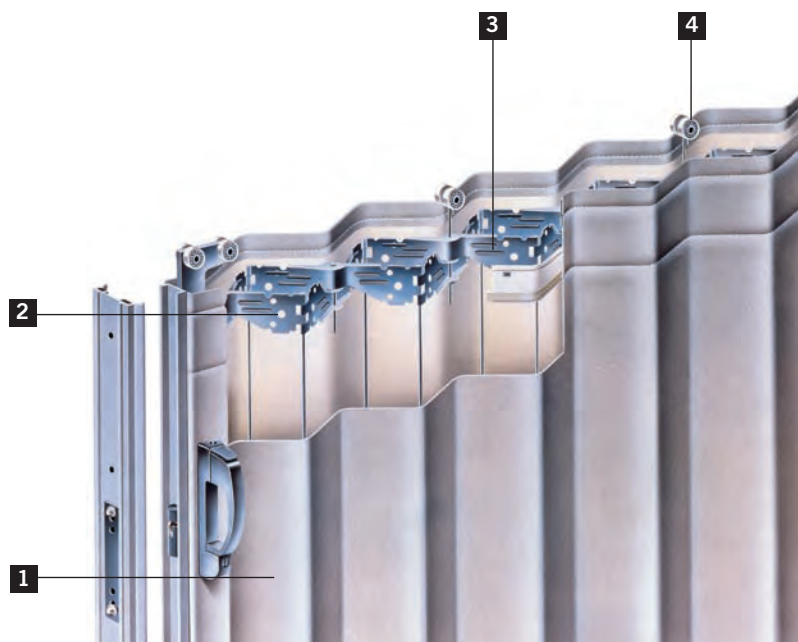

- 1** Easily replaceable Class A rated coverings
- 2** Continuous horizontal pantograph hinges
- 3** Three-dimensional welded steel frame
- 4** Ball-bearing trolleys with high tensile yokes

Accordion Door/Partitions Selector Guide

	Soundmaster				Modernfold			
Model	8M	8E	12M	12E	800M	800E	1200M	1200E
Stack Width	9-inch	9-inch	12-5/8 inch	12-5/8 inch	9-inch	9-inch	12-5/8 inch	12-5/8 inch
Stack Depth*	2-1/8 inch	2-1/8 inch	1-3/4 inch	1-3/4 inch	2-1/8 inch	2-1/8 inch	1-3/4 inch	1-3/4 inch
Operation	Manual	Electric	Manual	Electric	Manual	Electric	Manual	Electric
Frame	All Steel	All Steel	All Steel	All Steel	All Steel	All Steel	All Steel	All Steel
Skin/Face Options	Vinyl, Fabric, Carpet	Vinyl, Fabric, Carpet	Vinyl, Fabric, Carpet	Vinyl, Fabric, Carpet	Vinyl, Fabric, Carpet	Vinyl, Fabric, Carpet	Vinyl, Fabric, Carpet	Vinyl, Fabric, Carpet
	#7 Steel Track	#7 with Chain Guide	#7 Steel Track	#7 with Chain Guide	#7 Steel Track	#7 with Chain Guide	#7 Steel Track	#7 with Chain Guide
	#6 Steel Track	—	#6 Steel Track	—	#6 Steel Track	—	#6 Steel Track	—
Suspension Options	#5 Aluminum Track	—	—	—	#5 Aluminum Track	—	—	—
Hinge Type	All Steel	All Steel	All Steel	All Steel	All Steel	All Steel	All Steel	All Steel
Maximum Width**	50'-0"	50'-0"	60'-0"	60'-0"	50'-0"	50'-0"	60'-0"	60'-0"
Maximum Height	12'-0"	12'-0"	12'-0"	12'-0"	12'-0"	12'-0"	12'-0"	12'-0"
STC	39	39	40	40	N/A	N/A	N/A	N/A
Hanging Weight	4 lb/sq ft	4 lb/sq ft	5-lb/sq ft	5-lb/sq ft	2-lb/sq ft	2-lb/sq ft	2-3/4 lb/sq ft	2-3/4 lb/sq ft

* Per lineal foot of opening width, plus posts
** Paired partitions double maximum width

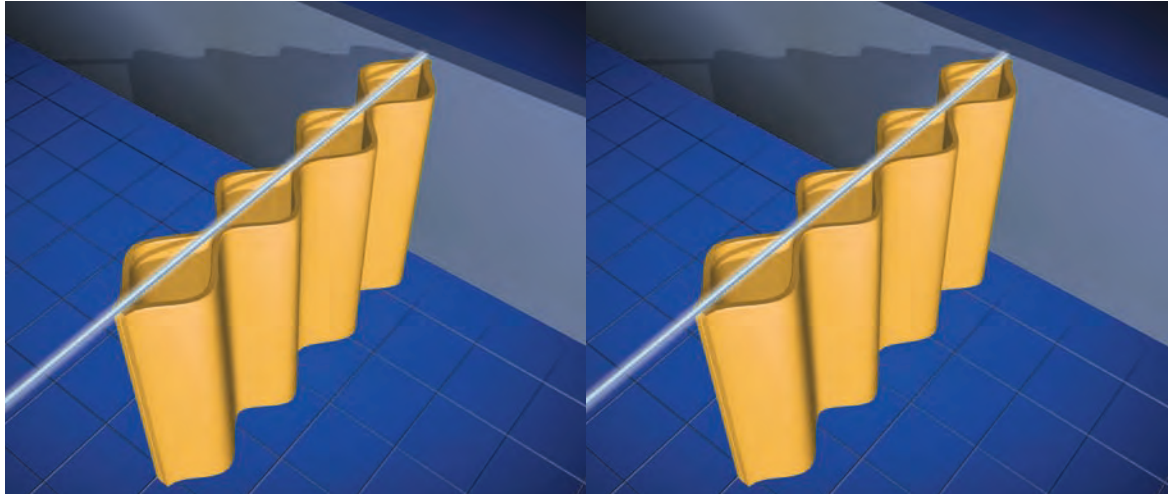

Manufacturer reserves the right to change or modify product or specifications at any time without prior notice. Soundmaster® and Modernfold® are registered trademarks of Modernfold, Inc.

MODERNFOLD™
A DORMA Group Company

Modernfold, Inc.
215 West New Road
Greenfield, IN 46140

Tel: 800-869-9685
Fax: 866-410-5016

e-mail: info@modernfold.com
www.modernfold.com

A DORMA Group Company
www.dorma-usa.com



Take concrete floors
to a higher level.



SkimStone Hybridized Portland Cement

A unique decorative finish for concrete

The perfect finish for every floor



The interior designer chose SkimStone for this urban loft to complement the exposed brick and concrete wall.



The ideal alternative to traditional flooring

Transform a concrete floor into a work of art

With SkimStone®, you can transform a concrete floor into a work of art. Our decorative finishing system provides an organic, textured look that's extremely durable – indoors and out. All it takes is a three-step application and a few simple tools to achieve one-of-a-kind results. SkimStone offers an exciting alternative to traditional paints and stains, is more predictable than acid stains, and more economical than many natural materials. Its unique beauty and tough surface are ideal for both homes and public spaces.

Artistic Effects

SkimStone is incredibly versatile, letting you mimic the look of marble, tile, granite and stone. Create patterns with stencils or by taping off areas between coats. For a more mottled appearance, use sponges, rags or brushes. It's easy to change the intensity of any color by changing the amount of tint used. You can also use a different color for each layer and mix tints to invent your own color.

Green Properties

SkimStone is a waterborne product, meeting Built Green, Build-It-Green and LEED specifications. It has low VOC emissions and is easy on the environment. SkimStone is non-toxic and cleans up with water. With its minimal build, SkimStone virtually eliminates tear-outs reducing landfill waste and costly disposal fees.

See where SkimStone can take your imagination:

For more information, visit your local retailer or

www.skimstone.com

Urban Enoteca,
a wine tasting venue,
used SkimStone to finish
16,000 square feet of
high-traffic flooring.



18 colors. 90 shades. Unlimited possibilities.



Colors shown here are approximate. The color and texture of the concrete, application method and use of sealer will affect the final color.

SkimStone is available at:

This mosaic is a beautiful example of the versatility of SkimStone. Look for more inspiration and ideas at www.skimstone.com



SkimStone is a registered trademark of Rudd Company, Inc.



Founded in 1912, Rudd Company is a leading manufacturer of quality paints and coatings

1141 NW 50th Street • Seattle, WA 98107 • 800.444.7833



TECHNICAL DATA SHEET Decorative Finish for Concrete Floors

PRODUCT DESCRIPTION

SkimStone is a two-component trowel applied cementitious decorative coating for existing concrete floors. The acrylic based Type I Solution is tinted using SkimStone ColorPaks, which can be added at varying strengths or combined to produce unique colors. The tinted Type I Solution is mixed with SkimStone White Powder to achieve the recommended viscosity. A basic three-coat application produces a unique textured appearance. SkimStone is sealed with SkimStone Protective Sealer, a 100% urethane waterborne sealer.

APPEARANCE

A trowel applied SkimStone application produces a unique organic appearance with depth of texture.

SURFACE PREPARATION

All concrete surfaces must be clean and free of all loose material (dirt and debris), oil, grease, glues or other contaminants. Previously sealed or painted concrete must be returned to bare concrete by mechanical grinding or shot blasting. To ensure adhesion on extremely smooth or slick concrete, surface texture (profile) created by mechanical abrasion is recommended. New concrete should be allowed to age at least three months prior to applying SkimStone. The concrete surface must be completely dry.

TINTING

SkimStone is tinted using SkimStone ColorPaks. These lead-free industrial grade acrylic colorants provide excellent color stability and fade resistance. Up to 8 ounces of ColorPak may be used to tint each gallon of Type I Solution. Note: Colors will appear different in the mixing bucket or when left unsealed when compared to the finished, sealed application.

MIXING

When mixing SkimStone, it is important to tint the amount of Type I Solution needed for the coat to be applied *prior* to adding the powder. SkimStone may be mixed either by hand or by using a mixing device such as an attachment for an electric drill. It is critical that both the ColorPak and powder are mixed completely into the Type I Solution until the mixture is smooth and free of lumps. The recommended consistency of the mixture will vary depending on the roughness of the substrate -- the rougher the substrate, the thicker the mixture. (See Coverage Chart) Stir mixture periodically during application to ensure even color.

APPLICATION

SkimStone is typically applied using a straight edged metal finishing trowel. Other trowels may be substituted and will render different appearances in the final product based on their size and shape. When applying SkimStone, it is important to hold the trowel at an angle so that only one edge is touching the floor. Apply using broad, sweeping, even strokes. As SkimStone dries it will be possible to see these strokes, so a determination in terms of workflow direction should be made prior to applying any subsequent coats.

DRYING TIME

Typical dry time is 30 minutes to 2 hours per coat, depending on temperature, humidity, and application thickness. Allow 8 hours or overnight dry before applying SkimStone Protective Sealer.

SEALING

SkimStone Protective Sealer is an easy to use 100% urethane waterborne sealer, designed for both interior and exterior applications. When used on interior surfaces, 4-5 coats are recommended for maximum sheen and protection. However, when used on exterior surfaces no more than two thin coats of sealer should be used to allow the concrete to breathe.

COVERAGE

Coverage varies from 400 -1200 ft² per gallon of Type I Solution depending on the roughness of the substrate. Protective Sealer coverage is up to 1600 ft² per gallon based on application technique and porosity of surface.

CLEANUP

Equipment and tools can be cleaned with water immediately after use. Dried material may be scraped or removed by sanding.

MAINTENANCE

Allow 24 hours to dry before permitting light foot traffic or moving in furniture. Maximum hardness of the Protective Sealer will be achieved in 7-10 days. Use floors with care during this period. Avoid contact with water. Do not cover with rugs and avoid sliding furniture across surface. Maintain by regular sweeping and vacuuming. Immediately wipe up spills with damp rag. Clean sealed surface with SkimStone Cleaner as needed. Use protective felt pads on furniture legs to protect from scratching.

APPLICATION PRECAUTIONS

- Always add the Powder to the colored Type I Solution. Doing the reverse will cause the material to become hard and unworkable.
- Use Type I Solution for thinning mixture. Do NOT thin with water.
- Do not exceed colorant tinting ratio of 8 oz per gallon of Type I Solution.
- Do not topcoat with waterbase acrylic sealers or finishes.
- Not recommended over silicone-based stains or sealers, even after removal.
- Not recommended over floors where previous coatings have been removed by acid etching.

SAFETY PRECAUTIONS

- Always wear a dust mask when working with the powder and sanding or abrading the surface.
- Wear protective eyewear to avoid accidental contact with eyes.
- Wear gloves when working with or handling SkimStone.

HELPFUL TIPS

- Make a basecoat for large, uneven surfaces. First, mix 2 parts sand (70 mesh) to 1 part SkimStone Powder. Then mix this dry blend with the Type I Solution at a ratio of 2½ parts dry to 1 part liquid.
- You want the concrete or basecoat to show through in places on the first coat. This helps to achieve the appearance of texture when the second and third coats are applied.
- To keep the application very thin, increase the pressure and the angle of the trowel.
- Pouring too much mixture on the surface can make it difficult to apply in a thin coat. Start with a cup or less and increase or decrease the amount to fit your level of comfort.
- You can save the SkimStone mixture overnight by pouring (floating) approximately 1 oz of colored Type I solution over the top. Place a layer of plastic wrap directly on the surface of the mixture to restrict contact with air. Cover container with aluminum foil and refrigerate. Overnight, SkimStone may become thick. Mixing will regain the appropriate consistency. Be sure to label and keep out of the reach of children!
- If you're applying SkimStone to a large area, a pair of kneepads is recommended.

PHYSICAL PROPERTIES

Product	Component	VOC	Viscosity	Wt/Gal	Freeze/Thaw Stable
Powder	Proprietary blend with Portland Cement	N/A	N/A	5.9	N/A
Type I Solution	Acrylic Emulsion Blend	<2 g/l	10 cps	8.53	Yes
Protective Sealer	Urethane Blend	<120g/l	50 cps	8.45	Yes
ColorPaks	Lead-Free Acrylic	<330g/l	>80KU	9.2-15.6	Yes

DOT CLASS / SHIPPING INFORMATION

Powder:	Case: 32 lbs. Pail: 32 lbs. Not Regulated
Type I Solution:	Case: 36 lbs. Pail: 45 lbs. W/B Paint – Not Regulated (Keep from Freezing)
Protective Sealer:	Case (Gals): 54 lbs. W/B Paint – Not Regulated (Keep from Freezing)
ColorPaks:	W/B – Not Regulated (Keep from Freezing)

WARRANTY

We guarantee that our products, in their original sealed containers, will be free of defects and conform to Rudd Company quality control specifications. We assume no responsibility for risks or liabilities resulting from the use or performance of this product since conditions of application are beyond our control.

Rudd Company, Inc.
800-444-7833
www.skimstone.com



1010 SLIDING MALL FRONT

ELEVATIONS/VERTICAL SECTION DETAILS	2
HORIZONTAL SECTION DETAILS	3
SIZE LIMITATIONS	5
GENERAL INFORMATION	5
HARDWARE	6

LAWS AND BUILDING AND SAFETY CODES GOVERNING THE DESIGN AND USE OF GLAZED ENTRANCE, WINDOW, AND CURTAIN WALL PRODUCTS VARY WIDELY. KAWNEER DOES NOT CONTROL THE SELECTION OF PRODUCT CONFIGURATIONS, OPERATING HARDWARE, OR GLAZING MATERIALS, AND ASSUMES NO RESPONSIBILITY THEREFOR.

Metric (SI) conversion figures are included throughout these details for reference. Numbers in parentheses () are millimeters unless otherwise noted.

The following metric (SI) units are found in these details:

- m – meter
- cm – centimeter
- mm – millimeter
- s – second
- Pa – pascal
- MPa – megapascal

Kawneer reserves the right to change configurations without prior notice when deemed necessary for product improvement.

1010 SLIDING MALL FRONT

ELEVATIONS/VERTICAL SECTION DETAILS



SCALE 3" = 1'-0"

NOTE: DOTTED LINES ON PLAN INDICATE OPTIONAL TRACK LAYOUT

OTHER CONFIGURATIONS AVAILABLE USING STANDARD COMPONENTS SHOWN.

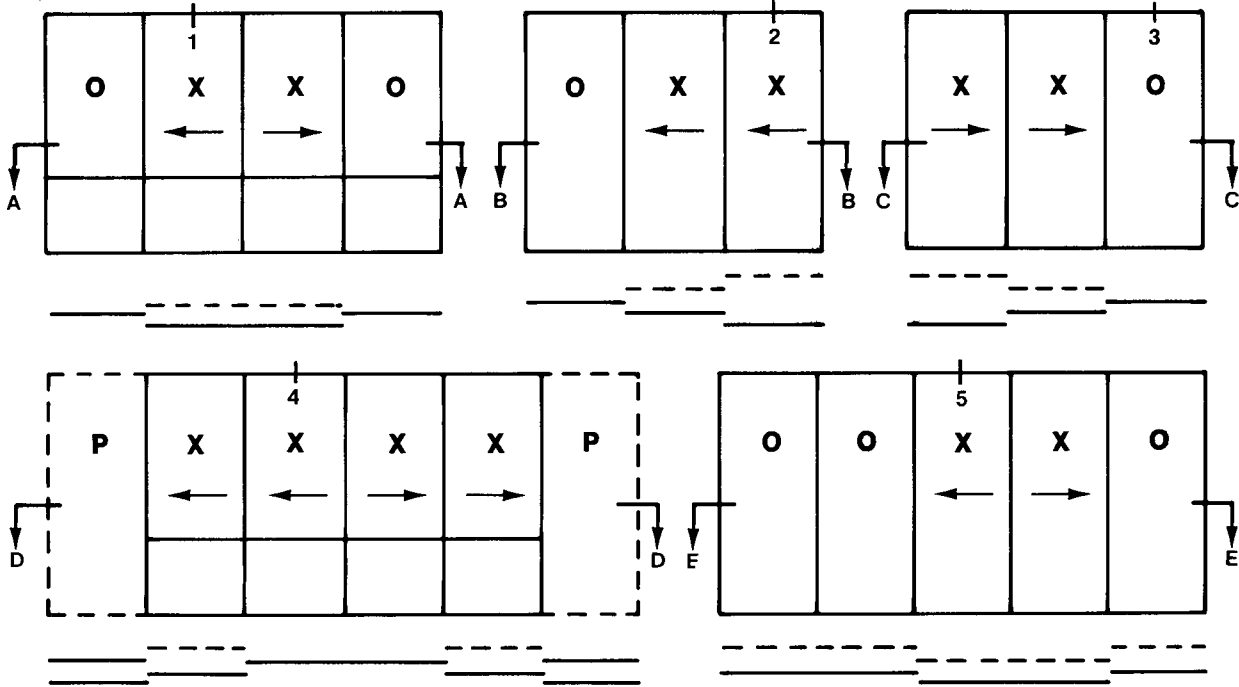

ELEVATIONS KEYED TO DETAILS BELOW AND ON PAGE 3

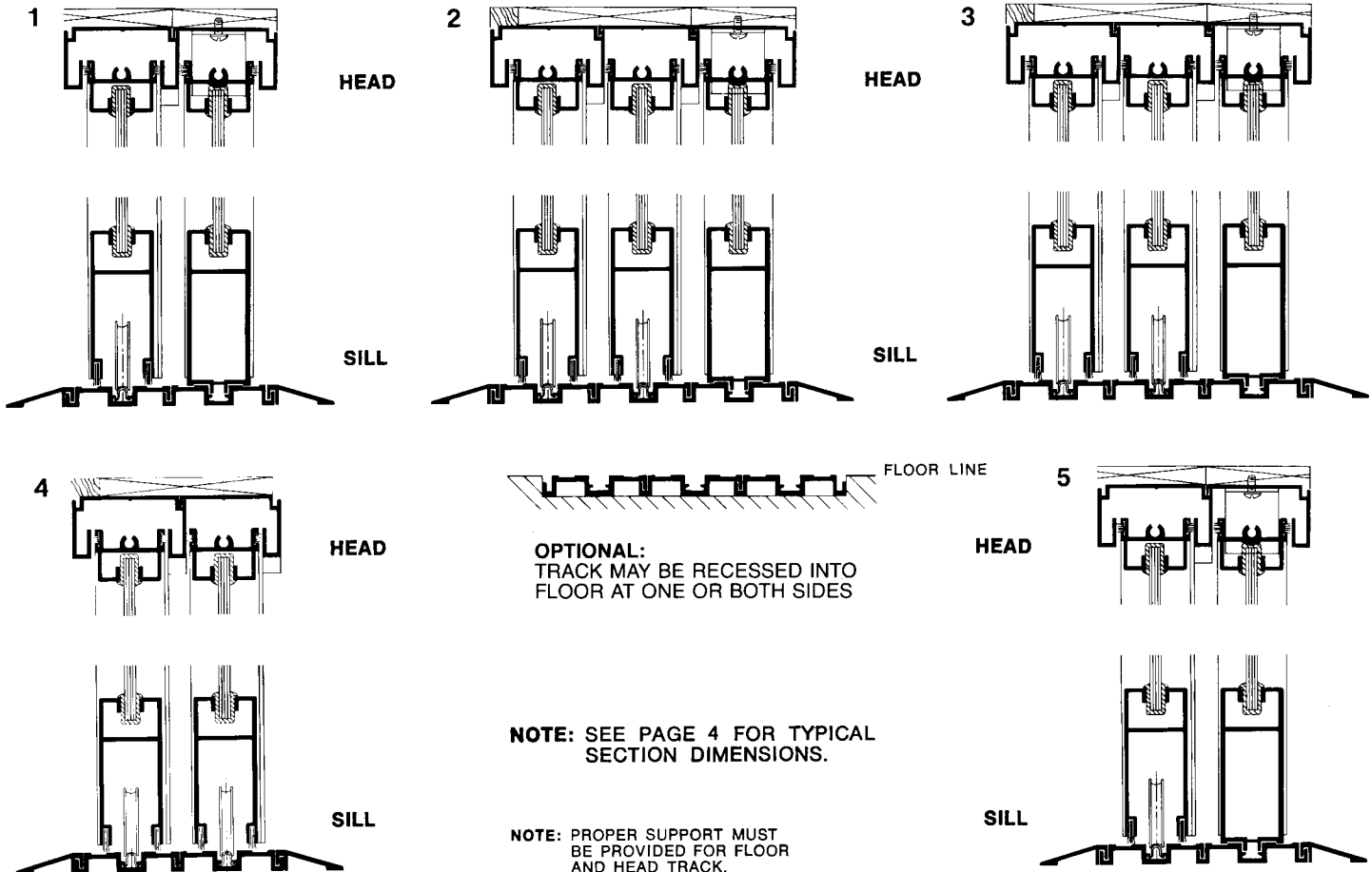

1010 SLIDING MALL FRONT

HORIZONTAL SECTION DETAILS



SCALE 3" = 1'-0"

NOTE: SEE PAGE 4 FOR TYPICAL SECTION DIMENSIONS

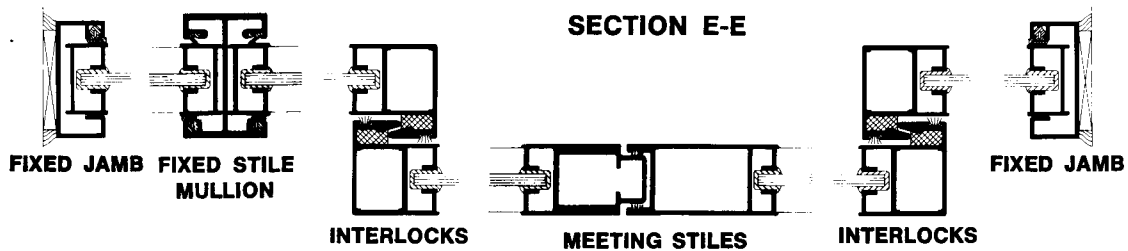
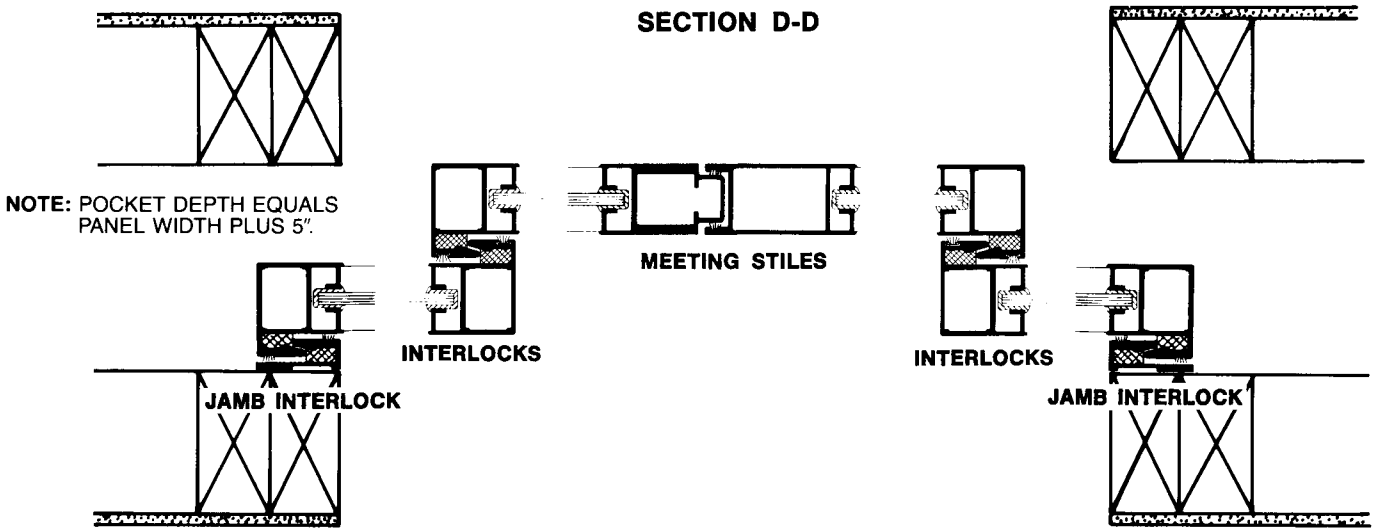
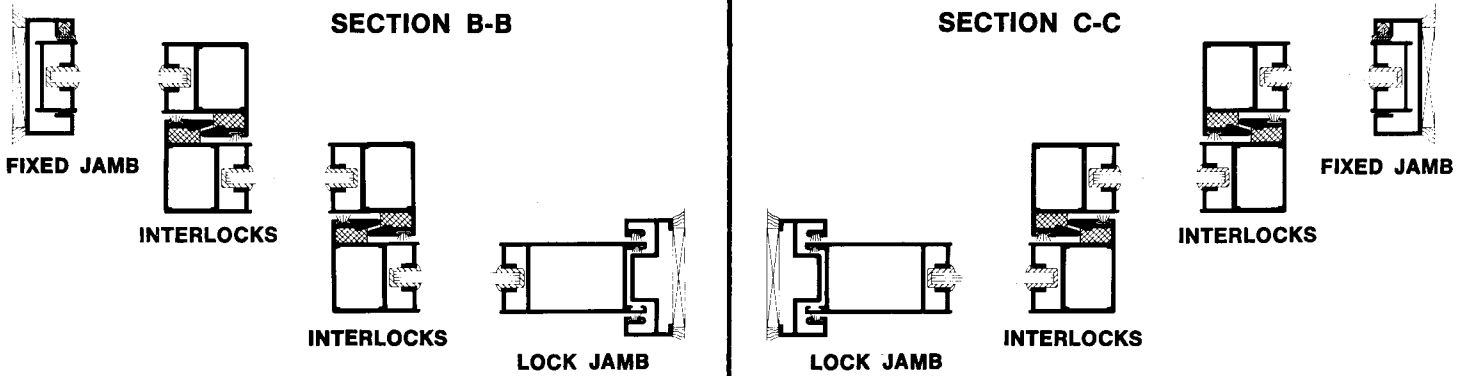
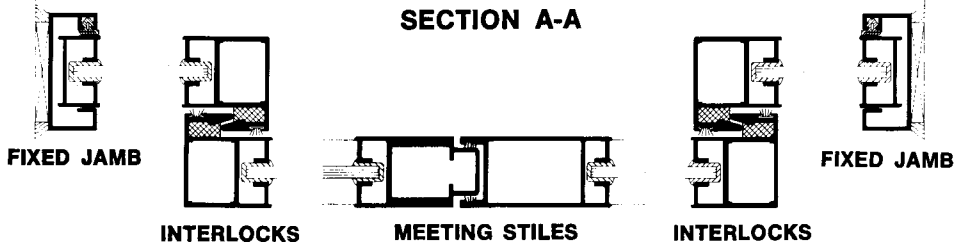

DRAFT

1010 SLIDING MALL FRONT

SIZE LIMITATIONS/GENERAL INFORMATION

MAXIMUM PANEL SIZE CHART INTERIOR APPLICATIONS ONLY

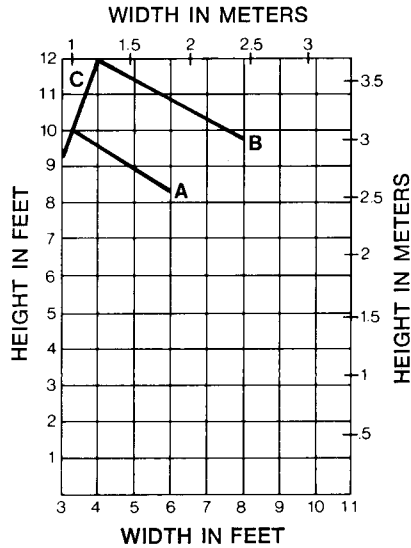

A Maximum panel size with standard interlocks (single glazing).

— AND —

Maximum panel size for double glazed units.

B Maximum panel size with heavy duty interlocks (single glazing).

C Panel width should be at least 1/3 panel height.

- GENERAL NOTES:** (1) ON PANELS OVER 10' IN HEIGHT AN INTERMEDIATE HORIZONTAL MUNTIN IS RECOMMENDED.
 (2) THIS IS NOT A WINDLOAD CHART FOR EXTERIOR APPLICATIONS.

GLAZING OPTIONS AVAILABLE



$\frac{3}{16}$ " (4.8) - $\frac{7}{32}$ " (5.6) - $\frac{1}{4}$ " (6.4)
SINGLE GLAZING



$\frac{3}{8}$ " (9.5)
SINGLE GLAZING
AND
 $\frac{5}{8}$ " (15.9) - 1" (25.4)
DOUBLE GLAZING

GENERAL INFORMATION

General Description: The "1010" sliding mall front is a multi-track unit primarily for interior applications. It is ideally suited for the following commercial applications.

- Enclosed shopping malls
- Sliding room dividers
- Institutional sliding doors
- Interior pocket doors.

1010 SLIDING MALL FRONT

HARDWARE

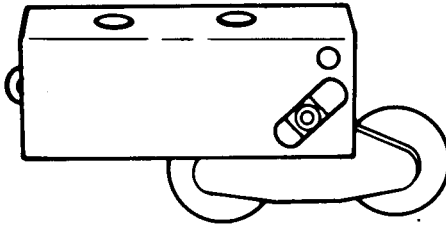

TANDEM CASTER

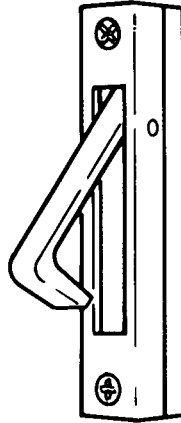
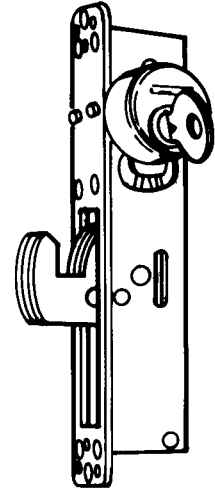
EDGE PULL
(OPTIONAL)FLUSH
FACE PULLMS 1850A-505
HOOK BOLT LOCK

EXTRUDED PULL

1010 SLIDING MALL FRONT

Standard Offering

- Tandem Casters
- Adams Rite Maximum Security 1850A-505 Hookbolt Lock
- 1 $\frac{5}{32}$ " (29.3) cylinders – One interior, one exterior
- Flush Face Pulls

Optional Offering

- Extruded pull in lieu of flush face pull
- Thumbturn (in lieu of interior cylinder)
- Adams Rite 1848 Hookbolt Lock w/5 pin cylinder (in lieu of A.R.M.S. 1850A-505)
- Stainless steel hookbolt and strike (not compatible with A.R.M.S. 1850A-505)
- Stainless steel rollers on tandem casters
- Bottom rail lock
- Cylinder operated flush bolts
- Manually operated flush bolt

Limitations

- Interlock stiles require notching if the lock cylinders for the A.R.M.S. 1850A-505 lock are to bypass the stiles.
- Thumbturns will not bypass interlock stiles.