

**TONGASS BOULEVARD  
RECONSTRUCTION  
PHASE 1**

**VOLUME I of I**

**Contract No. BE21-150**

File No. 2089



**ENGINEERING DEPARTMENT**

**SECTION 00005 - TABLE OF CONTENTS**

**DIVISION 0 - BIDDING AND CONTRACT REQUIREMENTS, CONTRACT FORMS, AND CONDITIONS OF THE CONTRACT**

**BIDDING and CONTRACT REQUIREMENTS No. of Pages**

00005	Table of Contents .....	2
00030	Notice Inviting Bids .....	2
00100	Instructions to Bidders .....	8
00210	Information to Bidders.....	1
00300	Bid .....	2
00310	Bid Schedule .....	2
00320	Bid Bond .....	1
00360	Subcontractor Report.....	3
00370	Contractor Financial Responsibility.....	3

**CONTRACT FORMS**

00500	Agreement .....	6
00610	Performance Bond .....	2
00620	Payment Bond .....	2

**CONDITIONS OF THE CONTRACT**

00700	General Conditions .....	48
00800	Supplementary General Conditions .....	6
00830	Alaska Labor Standards, Reporting, and Prevailing Wage Rate Determination.....	1
	Appendix A- Pamphlet 600- Effective April 1, 2021 .....	38
00852	Permits .....	1
00853	Standard Details.....	1

**TECHNICAL SPECIFICATIONS**

Special Provisions .....	69
--------------------------	----

**No. of Pages**

**LIST OF DRAWINGS – 23 SHEETS**

<u>Sheet No.</u>	<u>Description</u>
C001	Cover Sheet
C002	General Notes, Abbreviations and Symbols
C003	Survey Control Map
C004	Summary Tables
C100	Typical Sections
C101	Construction Details
C102	Construction Details
C103	Corrosion Protection Details
C200	Plan – Tongass Blvd, Trinity Drive to STA “T” 13+00
C201	Plan – Tongass Blvd, STA “T”13+00 to STA “T” 16+00

## SECTION 00005 - TABLE OF CONTENTS

C202	Plan – Tongass Blvd, STA “T” 16+00 to STA “T” 18+58
C203	Plan – Tongass Blvd, STA “T” 18+58 to EOP
C300	Profile – Tongass Blvd, Trinity Drive to STA “T” 16+00
C301	Profile – STA “T” 16+00 to EOP
C400	Pavement and Gutter Layout – Tongass Blvd, Trinity Drive to STA “T” 13+00
C401	Pavement and Gutter Layout – Tongass Blvd, STA “T” 13+00 to STA “T” 16+00
C402	Pavement and Gutter Layout – Tongass Blvd, STA “T” 16+00 to STA “T” 18+58
C403	Pavement and Gutter Layout – Tongass Blvd, STA “T” 18+58 to EOP
C500	Signing & Striping Plan
E001	Legend and Tables
E200	Electrical Plan – Trinity Drive to STA “T” 16+00
E201	Electrical Plan – STA “T” 16+00 to EOP
E300	Single Line Diagram and Details

**END OF SECTION**

**SECTION 00030 NOTICE INVITING BIDS**

**OBTAINING CONTRACT DOCUMENTS.** The Contract Documents are entitled:

**TONGASS BOULEVARD RECONSTRUCTION PHASE 1  
Contract No. BE21-150**

The Contract Documents may be downloaded for free at the CBJ Engineering Department webpage at: <https://juneau.org/engineering-public-works>.

**PRE-BID CONFERENCE.** Prospective Bidders are encouraged to attend a pre-Bid conference to discuss the proposed WORK, which will be conducted by the OWNER, at 10:00 a.m. on April 27, 2021. The object of the conference is to acquaint Bidders with the project and bid documents. Conference call capability will be available for the Pre-Bid meeting. Proposers intending to participate via conference call shall notify Paula Osborn in the CBJ Engineering Contracts Division, at (907) 586-0888, or [Contracts@Juneau.Org](mailto:Contracts@Juneau.Org) by 4:30 p.m., April 26, 2021.

**DESCRIPTION OF WORK.** The WORK covered in the Contract Documents includes reconstruction of Tongass Boulevard from the intersection of Trinity Drive to Dudley Street. Work generally includes clearing and grubbing, excavation, 2" minus shot rock with D-1 base course, storm drain improvements, replacement of existing water main, new water services, new fire hydrants, replacement of existing sewer main line, new sewer services, new sanitary sewer manholes, asphalt pavement, asphalt sidewalk, curb & gutter, mailboxes, traffic control signs, lighting, and other miscellaneous related WORK.

**COMPLETION OF WORK.** The WORK must be completed by October 1, 2021, or 120 days of issuance of Notice to proceed.

**DEADLINE FOR BIDDER QUESTIONS: May 4, 2021**

**DEADLINE FOR BIDS:** Sealed bids must be received by the Purchasing Division **prior to 2:00 p.m., Alaska Time on May 11, 2021,** or such later time as may be announced by addendum at any time prior to the deadline. Bids will be time and date stamped by the Purchasing Division, which will establish the official time of receipt of bids. Bids will be opened immediately thereafter. Bidders may attend this bid opening on the conference call line 907-713-2140, with participant code 258358.

Bid documents delivered in person or by **courier** service must be delivered to:

**PHYSICAL LOCATION:**  
City and Borough of Juneau, Purchasing Division  
105 Municipal Way, Room 300  
Juneau, AK 99801

Bid documents delivered by **U.S. Postal Service** must be mailed to:

**MAILING ADDRESS:**  
City and Borough of Juneau, Purchasing Division  
155 South Seward Street  
Juneau, AK 99801

**\* A face covering must be worn in the  
105 Municipal Way building per the  
CBJ Emergency Ordinance No. 2020-45**



**SECTION 00030 NOTICE INVITING BIDS**

Please affix the label below to outer envelope in the lower left hand corner.

<b>IMPORTANT NOTICE TO BIDDER</b>		
<b>To submit your Bid:</b>		
1. Print your company name and address on the upper left corner of your envelope.		
2. <b>Complete this label and place it on the lower left corner of your envelope.</b>		
<b>S E A L E D</b>	<b>BID NUMBER:</b>	<b>B I D</b>
	<u>BE21-150</u>	
	<b>SUBJECT:</b>	
	<u>TONGASS BLVD. RECONSTRUCTION, PHASE 1</u>	
	<b>DEADLINE DATE:</b>	
	<u>PRIOR TO 2:00PM ALASKA TIME</u>	

**Mailing/delivery times to Alaska may take longer than other areas of the U.S.** Late bids will not be accepted and will be returned.

**SITE OF WORK.** The site of the WORK is Tongass Boulevard in Juneau, Alaska between the Trinity Drive and Loop Road intersections.

**BIDDING, CONTRACT, or TECHNICAL QUESTIONS.** All communications relative to this WORK, prior to opening Bids, shall be directed to the following:

Greg Smith, Contract Administrator  
CBJ Engineering Department, 3<sup>rd</sup> Floor, Marine View Center  
Email: [greg.smith@juneau.org](mailto:greg.smith@juneau.org)  
Telephone: (907) 586-0873  
Fax: (907) 586-4530

**BID SECURITY.** Each Bid shall be accompanied by a certified or cashier's check or Bid Bond, in the amount of 5% percent of the Bid, payable to the City and Borough of Juneau, Alaska, as a guarantee that the Bidder, if its Bid is accepted, will promptly execute the Agreement. A Bid shall not be considered unless one of the forms of Bidder's security is enclosed with it.

**CONTRACTOR'S LICENSE.** All contractors are required to have a current Alaska Contractor's License, prior to submitting a Bid, and a current Alaska Business License prior to award.

**BID TO REMAIN OPEN.** The Bidder shall guarantee the Bid for a period of 120 Days from the date of Bid opening. Any component of the Bid may be awarded anytime during the 120 Days.

**SECTION 00030 NOTICE INVITING BIDS**

**OWNER'S RIGHTS RESERVED.** The OWNER reserves the right to reject any or all Bids, to waive any informality in a Bid, and to make award to the lowest responsive, responsible Bidder as it may best serve the interests of the OWNER.

**OWNER: City and Borough of Juneau**

By:  Date 4-15-2021  
Greg Smith, Contract Administrator

**END OF SECTION**

## SECTION 00100 - INSTRUCTIONS TO BIDDERS

**1.0 DEFINED TERMS.** Terms used in these Instructions to Bidders and the Notice Inviting Bids, which are defined in the General Conditions, have the meanings assigned to them in the General Conditions. The term "Bidder" means one who submits a Bid directly to the OWNER, as distinct from a sub-bidder, who submits a Bid to a Bidder.

### **2.0 INTERPRETATIONS AND ADDENDA.**

- A. **INTERPRETATIONS.** All questions about the meaning or intent of the Contract Documents are to be directed to the Engineering Contracts Administrator. Interpretations or clarifications considered necessary by the Engineering Contracts Administrator in response to such questions will be issued by Addendum, mailed, faxed, or delivered to all parties recorded by the Engineering Contracts Administrator, or OWNER, as having received the Contract Documents. Questions received less than seven Days prior to the Deadline for Bids may not be answered. Only questions answered by formal written Addendum will be binding. Oral and other interpretations or clarifications will be without legal effect.
- B. **ADDENDA.** Addenda may be issued to modify the Contract Documents as deemed advisable by the OWNER. Addenda may be faxed or, if addendum format warrants, addenda may be posted to the CBJ Engineering Department website. In any event, notification of addendum issuance will be faxed to planholders. Hard copies are available upon request. The OWNER will make all reasonable attempts to ensure that all planholders receive notification of Addenda, however, it is strongly recommended by the OWNER that bidders independently confirm the contents, number, and dates of each Addendum prior to submitting a Bid.

**3.0 FAIR COMPETITION.** More than one Bid from an individual, firm, partnership, corporation, or association under the same or different names will not be considered. If the OWNER believes that any Bidder is interested in more than one Bid for the WORK contemplated, all Bids in which such Bidder is interested will be rejected. If the OWNER believes that collusion exists among the Bidders, all Bids will be rejected.

**4.0 RESPONSIBILITY OF BIDDERS.** Only responsive Bids from responsible Bidders will be considered. A Bid submitted by a Bidder determined to be not responsible may be rejected. The OWNER may find a bidder to be not responsible for any one of the following reasons, but is not limited in its responsibility analysis to the following factors:

- A. Evidence of bid rigging or collusion;
- B. Fraud or dishonesty in the performance of previous contracts;
- C. Record of integrity;
- D. More than one bid for the same work from an individual, firm, or corporation under the same or different name;
- E. Unsatisfactory performance on previous or current contracts;
- F. Failure to pay, or satisfactorily settle, all bills due for labor and material on previous contracts;

## SECTION 00100 - INSTRUCTIONS TO BIDDERS

- G. Uncompleted work that, in the judgment of the OWNER, might hinder or prevent the bidder's prompt completion of additional work, if awarded;
- H. Failure to reimburse the OWNER for monies owed on any previous contracts;
- I. Default under previous contracts;
- J. Failure to comply with any qualification requirements of the OWNER; special standards for responsibility, if applicable, will be specified. These special standards establish minimum standards or experience required for a responsible Bidder on a specific contract;
- K. Engaging in any activity that constitutes a cause for debarment or suspension under the CBJ Procurement Code 53.50 or submitting a bid during a period of debarment;
- L. Lack of skill, ability, financial resources, or equipment required to perform the contract; or
- M. Lack of legal capacity to contract.
- N. Bidders must be registered as required by law and in good standing for all amounts owed to the OWNER per Paragraph 21.0 of this Section.
- O. Failure to submit all completed documents as required and specified on the Bid Form, Section 00300.

Nothing contained in this section deprives the OWNER of its discretion in determining the lowest responsible bidder. Before a Bid is considered for award, a Bidder may be requested to submit information documenting its ability and competency to perform the WORK, according to general standards of responsibility and any special standards which may apply. It is Bidder's responsibility to submit sufficient, relevant, and adequate information. OWNER will make its determination of responsibility and has no obligation to request clarification or supplementary information.

**5.0 NON-RESPONSIVE BIDS.** Only responsive Bids will be considered. Bids may be considered non-responsive and may be rejected. Some of the reasons a Bid may be rejected for being non-responsive are:

- A. If a Bid is received by the CBJ Purchasing Division after the Deadline for Bids.
- B. If the Bid is on a form other than that furnished by the OWNER, or legible copies thereof; or if the form is altered or any part thereof is detached; or if the Bid is improperly signed.
- C. If there are unauthorized additions, conditional or alternate Bids, or irregularities of any kind which may tend to make the bid incomplete, indefinite, ambiguous as to its meaning, or in conflict with the OWNER's Bid document.
- D. If the Bidder adds any unauthorized conditions, limitations, or provisions reserving the right to accept or reject any award, or to enter into a contract pursuant to an award. This does not exclude a Bid limiting the maximum gross amount of awards acceptable to any one Bidder at any one Bid opening, provided that any selection of awards will be made by the OWNER.
- E. If the Bid does not contain a Unit Price for each pay item listed, except in the case of

## SECTION 00100 - INSTRUCTIONS TO BIDDERS

authorized alternate pay items.

- F. If the Bidder has not acknowledged receipt of each Addendum.
- G. If the Bidder fails to furnish an acceptable Bid guaranty with the Bid.
- H. If any of the Unit Prices Bid are excessively unbalanced (either above or below the amount of a reasonable Bid) to the potential detriment of the OWNER.
- I. If a Bid modification does not conform to Article 15.0 of this Section.
- J. Failure to submit all completed documents as required and specified on the Bid Form, Section 00300.

### 6.0 BIDDER'S EXAMINATION OF CONTRACT DOCUMENTS AND SITE. It is the responsibility of each Bidder before submitting a Bid:

- A. To examine thoroughly the Contract Documents, and other related data identified in the Bidding documents (including "technical data" referred to below):
  - 1. To visit the site to become familiar with and to satisfy the Bidder as to the general and local conditions that may affect cost, progress, or performance, of the WORK,
  - 2. To consider federal, state and local laws and regulations that may affect cost, progress, or performance of the WORK,
  - 3. To study and carefully correlate the Bidder's observations with the Contract Documents, and other related data; and
  - 4. To notify the ENGINEER of all conflicts, errors, or discrepancies in or between the Contract Documents and such other related data.

### 7.0 REFERENCE IS MADE TO THE SUPPLEMENTARY GENERAL CONDITIONS FOR IDENTIFICATION OF:

- A. Those reports of explorations and tests of subsurface conditions at the site which have been utilized by the Engineer of Record in the preparation of the Contract Documents. The Bidder may rely upon the accuracy of the technical data contained in such reports, however, the interpretation of such technical data, including any interpolation or extrapolation thereof, together with non-technical data, interpretations, and opinions contained therein or the completeness thereof is the responsibility of the Bidder.
- B. Those Drawings of physical conditions in or relating to existing surface and subsurface conditions (except underground utilities) which are at or contiguous to the site have been utilized by the Engineer of Record in the preparation of the Contract Documents. The Bidder may rely upon the accuracy of the technical data contained in such Drawings, however, the interpretation of such technical data, including any interpolation or extrapolation thereof, together with nontechnical data, interpretations, and opinions contained in such Drawings or the completeness thereof is the responsibility of the Bidder.
- C. Copies of such reports and Drawings will be made available by the OWNER to any Bidder on request if said reports and Drawings are not bound herein. Those reports and Drawings are not part of the Contract Documents, but the technical data contained therein upon

## SECTION 00100 - INSTRUCTIONS TO BIDDERS

which the Bidder is entitled to rely, as provided in Paragraph SGC-4.2 of the Supplementary General Conditions, are incorporated herein by reference.

- D. Information and data reflected in the Contract Documents with respect to underground utilities at or contiguous to the site is based upon information and data furnished to the OWNER and the Engineer of Record by the owners of such underground utilities or others, and the OWNER does not assume responsibility for the accuracy or completeness thereof unless it is expressly provided otherwise in the Supplementary General Conditions, or in Section 01530 - Protection and Restoration of Existing Facilities of the General Requirements.
- E. Provisions concerning responsibilities for the adequacy of data furnished to prospective Bidders on subsurface conditions, underground utilities and other physical conditions, and possible changes in the Contract Documents due to differing conditions appear in Paragraphs 4.2, 4.3, and 4.4 of the General Conditions.
- F. Before submitting a Bid, each Bidder will, at Bidder's own expense, make or obtain any additional examinations, investigations, explorations, tests, and studies and obtain any additional information and data which pertain to the physical conditions (surface, subsurface, and underground utilities) at or contiguous to the site or otherwise which may affect cost, progress, or performance of the WORK and which the Bidder deems necessary to determine its Bid for performing the WORK in accordance with the time, price, and other terms and conditions of the Contract Documents.
- G. On request in advance, the OWNER will provide each Bidder access to the site to conduct such explorations and tests as each Bidder deems necessary for submission of a Bid. Bidder shall fill all holes and shall clean up and restore the site to its former condition upon completion of such explorations.
- H. The lands upon which the WORK is to be performed, rights-of-way and easements for access thereto and other lands designated for use by the CONTRACTOR in performing the WORK are identified in the Contract Documents. All additional lands and access thereto required for temporary construction facilities or storage of materials and equipment are to be provided by the CONTRACTOR. Easements for permanent structures or permanent changes in existing structures are to be obtained and paid for by the OWNER unless otherwise provided in the Contract Documents.
- I. The submission of a Bid will constitute an incontrovertible representation by the Bidder that the Bidder has complied with every requirement of Article 6.0, "Bidder's Examination of Contract Documents and Site" herein, that without exception the Bid is premised upon performing the WORK required by the Contract Documents and such means, methods, techniques, sequences, or procedures of construction as may be indicated in or required by the Contract Documents, and that the Contract Documents are sufficient in scope and detail to indicate and convey understanding of all terms and conditions for performance of the WORK.

### 8.0 BID FORM.

- A. The Bid shall be made on the Bid Schedule(s) bound herein, or on the yellow Bid packet provided, or on legible and complete copies thereof, and shall contain the following: Sections 00300, 00310, the required Bid Security, and any other documents required in

## SECTION 00100 - INSTRUCTIONS TO BIDDERS

Section 00300 – Bid.

- B. All blanks on the Bid Form and Bid Schedule must be completed in ink or typed.
- C. Bids by corporations must be executed in the corporate name by the president, a vice-president (or other corporate officer). The corporate address and state of incorporation must appear below the signature.
- D. Bids by partnerships must be executed in the partnership name and be signed by a managing partner, and the official address of the partnership must appear below the signature.
- E. The Bidder's Bid must be signed. All names must be printed or typed below the signature.
- F. The Bid shall contain an acknowledgment of receipt of all Addenda, the numbers of which shall be filled in on the Bid form. Failure to acknowledge Addenda may render Bid non-responsive and may cause its rejection.
- G. The address to which communications regarding the Bid are to be directed must be shown.

**9.0 QUANTITIES OF WORK.** The quantities of WORK, or material, stated in Unit Price items of the Bid are supplied only to give an indication of the general scope of the WORK; the OWNER does not expressly or by implication agree that the actual amount of WORK, or material, will correspond therewith, and reserves the right after award to increase or decrease the amount of any Unit Price item of the WORK by an amount up to and including 25 percent of any Bid item, without a change in the Unit Price, and shall include the right to delete any Bid item in its entirety, or to add additional Bid items up to and including an aggregate total amount not to exceed 25 percent of the Contract Price (see Section 00700 - General Conditions, Article 10 Changes In the WORK).

**10.0 SUBSTITUTE OR "OR-EQUAL" ITEMS.** Substitution requests are not accepted during the bidding process.

**11.0 SUBMISSION OF BIDS.** The Bid shall be delivered by the time and to the place stipulated in Section 00030 - Notice Inviting Bids. It is the Bidder's sole responsibility to see that its Bid is received in proper time. Oral, telegraphic, emailed, or faxed Bids will not be considered. The envelope enclosing the sealed Bids shall be plainly marked in the upper left-hand corner with the name and address of the Bidder and shall also include the label included in Section 00030 – Notice Inviting Bids. The Bid Security shall be enclosed in the same envelope with the Bid

**12.0 BID SECURITY, BONDS, AND INSURANCE.** Each Bid shall be accompanied by a certified, or cashier's check, or approved Bid Bond in an amount of at least 5 percent of the total Bid price. The "total Bid price" is the amount of the Base Bid, plus the amount of alternate Bids, if any, which total to the maximum amount for which the CONTRACT could be awarded. Said check or Bond shall be made payable to the OWNER and shall be given as a guarantee that the Bidder, if offered the WORK, will enter into an Agreement with the OWNER, and will furnish the necessary insurance certificates, Payment Bond, and Performance Bond; each of said Bonds, if required, and insurance amounts shall be as stated in the Supplementary General Conditions. In case of refusal or failure to enter into said Agreement, the check or Bid Bond, as the case may be, may be forfeited to the OWNER. If the Bidder elects to furnish a Bid Bond as its Bid security, the Bidder shall use

## SECTION 00100 - INSTRUCTIONS TO BIDDERS

the Bid Bond form bound herein, or one conforming substantially to it in form. Bid Bonds must be accompanied by a legible Power of Attorney.

**13.0 RETURN OF BID SECURITY.** The OWNER will return all Bid security checks (certified or cashier's) accompanying such of the Bids as are not considered in making the award. All other Bid securities will be held until the Agreement has been executed. Following execution of the Agreement, all other Bid security checks will be returned to the respective Bidders whose Bids they accompanied and Bid security bonds will be appropriately discarded.

**14.0 DISCREPANCIES IN BIDS.** In the event there is more than one Pay Item in a Bid Schedule, the Bidder shall furnish a price for all Pay Items in the schedule, and failure to do so may render the Bid non-responsive and cause its rejection. In the event there are Unit Price Pay Items in a Bid Schedule and the "amount" indicated for a Unit Price Bid Item does not equal the product of the Unit Price and quantity, the Unit Price shall govern and the amount will be corrected accordingly, and the Bidder shall be bound by said correction. In the event there is more than one Pay Item in a Bid Schedule and the total indicated for the schedule does not agree with the sum of the prices Bid on the individual items, the prices Bid on the individual items shall govern and the total for the schedule will be corrected accordingly, and the Bidder shall be bound by said correction.

### **15.0 BID MODIFICATIONS AND UNAUTHORIZED ALTERNATIVE BIDS.**

- A. Any bidder may deliver a modification to a bid in person, by mail or fax (907-586-4561), provided that such modification is received by the Purchasing Division no later than the deadline for bids. Modifications will be time and date stamped by the Purchasing Division, which will establish the official time of receipt of the modification. The modification must not reveal the bid price but should be in the form of an addition or subtraction or other modification so that the final prices will not be known until the sealed bid is opened.

The Bid modifications shall be provided on the **Bid Modification Form** located at the end of this Section. Submittal of any other form by the vendor may deem the modification unacceptable by the OWNER. **A mail or fax modification should not reveal the Bid price but should provide the addition or subtraction or other modification so that the final prices will not be known by the City and Borough until the sealed Bid is opened.** Submitted Modification forms shall include the modification to the unit price or lump sum amount of each pay item modified.

**FAX DISCLAIMER:** It is the responsibility of the bidder to submit modifications in a timely manner. Bidders' use of a fax machine to modify their bid shall be at bidders' sole risk. The Purchasing Division will attempt to keep the fax machine in good working order but will not be responsible for bid modifications that are late due to mechanical failure, a busy fax machine, or any other cause arising from bidder's use of a fax machine, even if bidder submits a transmission report or provides other confirmation indicating that the bidder transmitted a bid modification prior to the deadline. The City will not be responsible for its failure to receive the modification whether such failure is caused by equipment or human error, or otherwise. Bidders are therefore strongly encouraged to confirm receipt of their bid modification with the Purchasing Division (907-586-5258) prior to deadline.

- B. Conditioned bids, limitations, or provisos attached to the Bid or bid modification will render it unauthorized and cause its rejection as being non-responsive. The completed



## SECTION 00100 - INSTRUCTIONS TO BIDDERS

Bid forms shall be without interlineations, alterations, or erasures in the printed text. All changes shall be initialed by the person signing the Bid. Alternative Bids will not be considered unless called for.

**16.0 WITHDRAWAL OF BID.** Prior to the Deadline for Bids, the Bid may be withdrawn by the Bidder by means of a written request, signed by the Bidder or its properly authorized representative. Such written request must be delivered to the place stipulated in the Notice Inviting Bids for receipt of Bids.

### **17.0 AWARD OF CONTRACT.**

- A. Award of a contract, if it is awarded, will be on the basis of materials and equipment described in the Drawings or specified in the Technical Specifications and will be made to the lowest responsive, responsible Bidder whose Bid complies with all the requirements prescribed. Unless otherwise specified, any such award will be made within the period stated in the Notice Inviting Bids that the Bids are to remain open. Unless otherwise indicated, a single award will be made for all the Bid items in an individual Bid Schedule.
- B. If the OWNER has elected to advertise this Project with a Base Bid and Alternates, the OWNER may elect to award the contract for the Base Bid, or the Base Bid in combination with one or more Alternates selected by the OWNER. In either case, award shall be made to the responsive, responsible bidder offering the lowest total Bid for the WORK to be awarded.

### **18.0 EXECUTION OF AGREEMENT.**

- A. All Bids of value greater than \$1,000,000 must be approved by the CBJ Assembly. After the CBJ Assembly has approved the award and after the Bid protest period, the OWNER will issue a Notice of Intent to Award to the approved Bidder. The Bidder to whom award is made shall execute a written Agreement with the OWNER on the Agreement form, Section 00500, collect insurance, and shall furnish all certificates and Bonds required by the Contract Documents within 10 Days (calendar) from the date of the Notice of Intent to Award letter.
- B. Failure or refusal to enter into the Agreement as herein provided or to conform to any of the stipulated requirements in connection therewith shall be just cause for annulment of the award and forfeiture of the Bid security. If the lowest responsive, responsible Bidder refuses or fails to execute the Agreement, the OWNER may award the contract to the second lowest responsive, responsible Bidder. If the second lowest responsive, responsible Bidder refuses or fails to execute the Agreement, the OWNER may award the contract to the third lowest responsive, responsible Bidder. On the failure or refusal of such second or third lowest Bidder to execute the Agreement, each such Bidder's Bid securities shall be likewise forfeited to the OWNER.

**19.0 LIQUIDATED DAMAGES.** Provisions for liquidated damages if any, are set forth in Section 00500 - Agreement.

### **20.0 FILING A PROTEST.**

- A. A Bidder may protest the proposed award of a competitive sealed Bid by the City and Borough of Juneau. The protest shall be executed in accordance with CBJ Ordinance

## SECTION 00100 - INSTRUCTIONS TO BIDDERS

53.50.062 PROTESTS and CBJ Ordinance 53.50.080 ADMINISTRATION OF PROTEST. The entire text of the CBJ Purchasing Ordinance can be accessed at the CBJ website, <http://www.juneau.org/law/code/code.php>, or call the CBJ Purchasing Division at (907) 586-5258 for a copy of the ordinance.

B. Late protests shall not be considered by the CBJ Purchasing Officer.

**21.0 CONTRACTOR'S GOOD STANDING WITH CBJ FINANCE DEPARTMENT:** Contractors must be in good standing with the CBJ prior to award, and prior to any contract renewals, and in any event no later than *seven business days* following notification by the CBJ of intent to award. **Good standing** means: all amounts owed to the CBJ are current and the Contractor is not delinquent with respect to any taxes, fees, assessment, or other monies due and owed the CBJ, or a Confession of Judgment has been executed and the Contractor is in compliance with the terms of any stipulation associated with the Confession of Judgment, including being current as to any installment payments due; and Contractor is current in all CBJ reporting obligations (such as sales tax registration and reporting and business personal property declarations). Failure to meet these requirements may be cause for rejection of your bid. To determine if your business is in good standing, or for further information, contact the CBJ Finance Department's Sales Tax Division at (907) 586-5265 for sales tax issues, Assessor's Office at (907)586-0930 for business personal property issues, or Collections Division at (907) 586-5268 for all other accounts.

**22.0 PERMITS AND LICENSES.** The CONTRACTOR is responsible for all WORK associated with meeting any local, state, and/or federal permit and licensing requirements.

**SECTION 00100 - INSTRUCTIONS TO BIDDERS**

CITY AND BOROUGH OF JUNEAU  
PURCHASING DIVISION  
FAX NO. 907-586-4561

**BID MODIFICATION FORM**

Modification Number: \_\_\_\_\_

Modification Page \_\_\_\_ of \_\_\_\_

Note: All modifications shall be made to the original bid amount(s). If more than one Modification form is submitted by any one bidder, changes from all Modification forms submitted will be combined and applied to the original bid. Changes to the modified Bid amounts will be calculated by the OWNER. Bidder may use multiple modification pages if required.

<b>PAY ITEM NO.</b>	<b>PAY ITEM DESCRIPTION</b>	<b>MODIFICATIONS TO UNIT PRICE OR LUMP SUM (<i>indicate +/-</i>)</b>

**Base Bid Total Increase or Decrease: \$ \_\_\_\_\_**

\_\_\_\_\_  
**Name of Bidding Firm**

\_\_\_\_\_  
**Responsible Party Signature**

\_\_\_\_\_  
**Printed Name (must be an authorized signatory for Bidding Firm)**

**END OF SECTION**

**SECTION 00300 - BID**

**BID TO: THE CITY AND BOROUGH OF JUNEAU**

1. The undersigned Bidder proposes and agrees, if this Bid is accepted, to enter into an Agreement with the OWNER on the form included in the Contract Documents (as defined in Article 7 of Section 00500 - Agreement) to perform the WORK as specified or indicated in said Contract Documents entitled

**Tongass Boulevard Reconstruction, Phase 1  
Contract No. BE21-150**

2. Bidder accepts all of the terms and conditions of the Contract Documents, including without limitation those in the "Notice Inviting Bids" and "Instructions to Bidders," dealing with the disposition of the Bid Security.
3. This Bid will remain open for the period stated in the "Notice Inviting Bids" unless otherwise required by law. Bidder will enter into an Agreement within the time and in the manner required in the "Notice Inviting Bids" and the "Instructions to Bidders," and will furnish insurance certificates, Payment Bond, Performance Bond, and any other documents as may be required by the Contract Documents.
4. Bidder has familiarized itself with the nature and extent of the Contract Documents, WORK, site, locality where the WORK is to be performed, the legal requirements (federal, state and local laws, ordinances, rules, and regulations), and the conditions affecting cost, progress or performance of the WORK and has made such independent investigations as Bidder deems necessary.
5. This Bid is genuine and not made in the interest of or on behalf of any undisclosed person, firm or corporation and is not submitted in conformity with any agreement or rules of any group, association, organization or corporation; Bidder has not directly or indirectly induced or solicited any other Bidder to submit a false or sham Bid; Bidder has not solicited or induced any person, firm or corporation to refrain from bidding; and Bidder has not sought by collusion to obtain for itself any advantage over any other Bidder or over OWNER.
6. To all the foregoing, and including all Bid Schedule and information required of Bidder contained in this Bid Form, said Bidder further agrees to complete the WORK required under the Contract Documents within the Contract Time stipulated in said Contract Documents, and to accept in full payment therefore the Contract Price based on the total bid price(s) named in the aforementioned Bid Schedule.
7. Bidder has examined copies of all the Contract Documents including the following Addenda (receipt of all of which is hereby acknowledged by the Undersigned):

Addenda No.	Date Issued	Addenda No.	Date Issued

**Give number and date of each Addenda above. Failure to acknowledge receipt of all Addenda may cause the Bid to be non-responsive and may cause its rejection.**

**SECTION 00300 - BID**

8. The Bidder has read this Bid and agrees to the conditions as stated herein by signing its signature in the space provided below.

Dated: _____	Bidder: _____ (Company Name)
Alaska CONTRACTOR's Business License No: _____	By: _____ (Signature)
Alaska CONTRACTOR's License No: _____	Printed Name: _____ Title: _____
Telephone No: _____	Address: _____ (Street or P.O. Box)
Fax No: _____	_____ (City, State, Zip)
E-mail: _____	

9. TO BE CONSIDERED, ALL BIDDERS MUST COMPLETE AND INCLUDE THE FOLLOWING AT THE TIME OF THE DEADLINE FOR BIDS. MISSING DOCUMENTS WILL DEEM THIS BID NON-RESPONSIVE:

- Bid, Section 00300 (includes Addenda receipt statement)
- Completed Bid Schedule, Section 00310
- Bid Security (Bid Bond, Section 00320, or by a certified or cashier's check as stipulated in the Notice Inviting Bids, Section 00030)
- **Contractor Financial Responsibility, Section 00370**

10. The apparent low Bidder is required to complete and submit the following documents by 4:30 p.m. on the *fifth business day* following the date of the Posting Notice.

- Subcontractor Report, Section 00360

The apparent low Bidder who fails to submit the completed Subcontractor Report within the time specified in Section 00360 – Subcontractor Report, may be found to be not a responsible Bidder and may be required to forfeit the Bid security. The OWNER may then consider the next lowest Bidder for award of the contract.

11. The successful Bidder will be required to submit, *within ten Days (calendar)* after the date of the “Notice of Intent to Award” letter, the following executed documents:

- Agreement Forms, Section 00500
- Performance Bond, Section 00610
- Payment Bond, Section 00620
- Certificates of Insurance, (CONTRACTOR) Section 00700 and Section 00800

**END OF SECTION**

**SECTION 00310 - BID SCHEDULE**

PAY ITEM NO.	PAY ITEM DESCRIPTION	PAY UNIT	APPROX. QUANTITY	UNIT PRICE		AMOUNT	
				DOLLARS	CENTS	DOLLARS	CENTS
1505.1	Mobilization	Lump Sum	All Req'd	LUMP	SUM		
1570.1	Erosion and Sediment Control	Lump Sum	All Req'd	LUMP	SUM		
2201.1	Clearing and Grubbing	Lump Sum	All Req'd	LUMP	SUM		
2202.1	Excavation	CY	1,960				
2202.2	Sideslopes and Ditch Grading	Lump Sum	All Req'd	LUMP	SUM		
2202.3	Mining Area Restoration and Road Cleaning Guarantee	Contingent Sum	All Req'd	Contingent	Sum	\$ 5,000	00
2204.1	2-Inch Minus Shot Rock w/ Base Course	CY	1,470				
2204.2	Base Course, Grading D-1 for Driveways	Ton	20				
2401.1	Sanitary Sewer Pipe, 8-Inch PVC	LF	1,037				
2401.2	Sanitary Sewer Pipe, 12-Inch PVC	LF	41				
2401.3	Service Connections and Laterals	Each	7				
2401.4	Locate Sanitary Sewer Services	Lump Sum	All Req'd	LUMP	SUM		
2401.5	Connect to Existing Sanitary Sewer Pipe	Each	7				
2402.1	Liner	Each	6				
2501.1	4 & 6-Inch Pipe Culvert	LF	100				
2501.2	12-Inch Pipe Culvert	LF	287				
2501.3	18-Inch Pipe Culvert	LF	164				
2501.4	24-Inch Pipe Culvert	LF	972				
2501.5	6-Inch Underdrain	LF	244				
2501.6	CPP Saddle Tee	Each	2				
2502.1	Storm Drain Manhole, Type I	Each	8				
2502.2	Storm Drain Manhole, Type II	Each	1				
2502.3	Catch Basin, Type IV	Each	2				
2502.4	Catch Basin, Type III	Each	3				
2502.5	24-Inch CPP Inlet	Each	5				
2502.6	Connect to Dissimilar Storm Drain Pipe	Each	1				
2601.1	10-Inch HDPE Water Pipe	LF	219				
2601.2	24-Inch HDPE Water Pipe	LF	945				
2601.3	Connect to Existing Water Pipe	Each	7				
2601.4	Temporary Water System	Lump Sum	All Req'd	LUMP	SUM		
2601.5	Corrosion Protection	Each	11				
2602.1	10-Inch Gate Valve	Each	5				
2602.2	24-Inch Butterfly Valve	Each	4				
2603.1	Fire Hydrant Assembly with Access Pad	Each	3				
2604.1	Air Release Valve	Each	1				
2605.1	1-Inch Poly Water Services	Each	6				
2605.2	4-Inch HDPE Water Services	Each	1				
2605.3	Locate Water Services	Lump Sum	All Req'd	LUMP	SUM		
2607.1	Pipe Insulation	Board	120				
2702.1	Construction Surveying	Lump Sum	All Req'd	LUMP	SUM		
2707.1	Remove and Reset Chain Link Fence	LF	93				
2707.2	Remove and Reset Wood Fence	LF	90				
2709.1	Topsoil	CY	60				

**SECTION 00310 - BID SCHEDULE**

PAY ITEM NO.	PAY ITEM DESCRIPTION	PAY UNIT	APPROX. QUANTITY	UNIT PRICE		AMOUNT	
				DOLLARS	CENTS	DOLLARS	CENTS
2709.2	Topsoil Finish Grading	MH	30				
2710.1	Seeding, Hydraulic Method, Type III	SU	1				
2716.1	Remove and Dispose of Storm and Sanitary Sewer Pipe	Lump Sum	All Req'd	LUMP	SUM		
2716.2	Fill Water Pipe with Slurry	Lump Sum	All Req'd	LUMP	SUM		
2717.1	Remove and Dispose of Storm and Sanitary Sewer Structures	Lump Sum	All Req'd	LUMP	SUM		
2718.1	Sign Assembly	Each	12				
2719.1	Reconstruct Mailbox	Each	10				
2720.1	Painted Traffic Markings	Lump Sum	All Req'd	LUMP	SUM		
2722.1	Relocate Electrical Conductor	Each	18				
2723.1	Remove and Relocate Landscaping	Lump Sum	All Req'd	LUMP	SUM		
2801.1	A.C. Pavement, Type II-A, Class B	Ton	656				
2801.2	Pads	SY	1,122				
2806.1	Remove Existing Asphalt Surfacing	SY	4,700				
3302.1	Concrete Area Drains	Each	7				
3302.2	Concrete Headwall with Hinged Trash Rack	Each	2				
3303.1	Concrete Access Pad, 6-Inches Thick with Detectable Tiles	SY	110				
3303.2	Concrete Sidewalk, 6-Inches Thick	SY	112				
3303.3	Concrete Curb and Gutter, Type I	LF	1,835				
3304.1	Removal of Concrete Sidewalks	SY	128				
3304.2	Removal of Curb and Gutter	LF	1,554				
260000.1	Lighting	Lump Sum	All Req'd	LUMP	SUM		

**TOTAL BASE BID \$ \_\_\_\_\_**

**COMPANY NAME: \_\_\_\_\_**

**SECTION 00320 - BID BOND**

KNOW ALL PERSONS BY THESE PRESENTS, that \_\_\_\_\_  
\_\_\_\_\_ as Principal, and \_\_\_\_\_  
as Surety, are held and firmly bound unto **THE CITY AND BOROUGH OF JUNEAU** hereinafter called  
"OWNER," in the sum of \_\_\_\_\_  
\_\_\_\_\_ dollars, (not less than five percent of the total amount of the Bid) for the  
payment of which sum, well and truly to be made, we bind ourselves, our heirs, executors, administrators,  
successors, and assigns, jointly and severally, firmly by these presents.

WHEREAS, said Principal has submitted a Bid to said OWNER to perform the WORK required under  
the Bid Schedule of the OWNER's Contract Documents entitled.

**TONGASS BOULEVARD RECONSTRUCTION PHASE 1  
Contract No. BE21-150**

NOW THEREFORE, if said Principal is awarded a contract by said OWNER and, within the time and  
in the manner required in the "Notice Inviting Bids" and the "Instructions to Bidders" enters into a written  
Agreement on the form of Agreement bound with said Contract Documents, furnishes the required certificates  
of insurance, and furnishes the required Performance Bond and Payment Bond, then this obligation shall be  
null and void, otherwise it shall remain in full force and effect. In the event suit is brought upon this bond by  
said OWNER and OWNER prevails, said Surety shall pay all costs incurred by said OWNER in such suit,  
including a reasonable attorney's fee to be fixed by the court.

SIGNED AND SEALED, this \_\_\_\_\_ day of \_\_\_\_\_, 20\_\_

(SEAL) \_\_\_\_\_  
(Principal)

(SEAL) \_\_\_\_\_  
(Surety)

By: \_\_\_\_\_  
(Signature)

By: \_\_\_\_\_  
(Signature)

**END OF SECTION**



**SECTION 00360 - SUBCONTRACTOR REPORT**

**LIST OF SUBCONTRACTORS (AS 36.30.115)**

The apparent low Bidder must submit a list of Subcontractors that the Bidder proposes to use in the performance of this contract *on the fifth business day* following the Posting Notice of Bids. If the fifth day falls on a weekend or holiday, the report is due by close of business on the next business Day following the weekend or holiday. The Subcontractor Report list must include each Subcontractor's name, address, location, evidence of valid Alaska Business License, and valid Alaska Contractor's Registration under AS 08.18. *If no Subcontractors are to be utilized in the performance of the WORK, write in ink or type "NONE" on line (1) below.*

<u>SUBCONTRACTOR</u>	<sup>1</sup> AK Contractor License No.	<sup>1</sup> Contact Name	Type of	Contract	✓ if DBE
<u>ADDRESS</u>	<sup>2</sup> AK Business License No.	<sup>2</sup> Phone No.	<u>Work</u>	<u>Amount</u>	
1. _____ _____ _____	1 _____ 2 _____	_____ _____	_____ _____	\$ _____	<input type="checkbox"/>
2. _____ _____ _____	1 _____ 2 _____	_____ _____	_____ _____	\$ _____	<input type="checkbox"/>
3. _____ _____ _____	1 _____ 2 _____	_____ _____	_____ _____	\$ _____	<input type="checkbox"/>
4. _____ _____ _____	1 _____ 2 _____	_____ _____	_____ _____	\$ _____	<input type="checkbox"/>

I certify that the above listed Alaska Business License(s) and CONTRACTOR Registration(s), if applicable, were valid at the time Bids were opened for this Project.

\_\_\_\_\_  
CONTRACTOR, Authorized Signature

\_\_\_\_\_  
CONTRACTOR, Printed Name

\_\_\_\_\_  
COMPANY

## SECTION 00360 - SUBCONTRACTOR REPORT

- A. A Bidder may replace a listed Subcontractor if the Subcontractor:
1. fails to comply with AS 08.18;
  2. files for bankruptcy or becomes insolvent;
  3. fails to execute a contract with the Bidder involving performance of the WORK for which the Subcontractor was listed and the Bidder acted in good faith;
  4. fails to obtain bonding;
  5. fails to obtain insurance acceptable to the OWNER;
  6. fails to perform the contract with the Bidder involving work for which the Subcontractor was listed;
  7. must be substituted in order for the CONTRACTOR to satisfy required state and federal affirmative action requirements;
  8. refuses to agree or abide with the Bidder's labor agreement; or
  9. is determined by the OWNER not to be responsible.
  10. is not in "Good Standing" with the OWNER as required in Article 21.0 in Section 00100 – Instructions to Bidders.
- B. If a Bidder fails to list a Subcontractor or lists more than one Subcontractor for the same portion of WORK, the Bidder shall be considered to have agreed to perform that portion of WORK without the use of a Subcontractor and to have represented the Bidder to be qualified to perform that WORK.
- C. A Bidder who attempts to circumvent the requirements of this section by listing as a Subcontractor another contractor who, in turn, sublets the majority of the WORK required under the contract violates this section.
- D. If a contract is awarded to a Bidder who violates this section, the OWNER may:
1. cancel the contract; or
  2. after notice and a hearing, assess a penalty on the Bidder in an amount that does not exceed 10 percent of the value of the subcontract at issue.
- E. On the Subcontractor Report, the apparent low Bidder must list all Subcontractors anticipated to perform WORK on the project.
- F. An apparent low Bidder who fails to submit a completed Subcontractor Report within the time specified in this section may be found to be not a responsible Bidder and may be required to forfeit the Bid security. The OWNER will then consider the next lowest Bidder for award of the contract.

**END OF SECTION**

**SECTION 00370 - CONTRACTOR'S FINANCIAL RESPONSIBILITY**

To be considered, all bidders must complete and include this form *at the time of the deadline for bids*. Attach additional sheets as necessary to respond to questions.

**PROJECT: TONGASS BOULEVARD RECONSTRUCTION PHASE 1**

As the General Contractor on this project, I intend to subcontract \_\_\_\_\_% of the total value of this contract.

**A. EXPERIENCE**

1. Have you ever failed to complete a contract due to insufficient resources?

No  Yes If YES, explain:

---

---

---

---

2. Describe arrangements you have made to finance this work:

---

---

---

---

3. Have you had previous construction contracts or subcontracts with the City and Borough of Juneau?

Yes  No

4. Describe your most recent or current contract, its completion date, and scope of work:

---

---

---

---

---

---

5. List below, and/or as an attachment to this questionnaire, other construction projects you have completed, dates of completion, scope of work, and total contract amount for each project completed in the past twelve months.

---

---

---

---

---

**SECTION 00370 - CONTRACTOR'S FINANCIAL RESPONSIBILITY**

6. Per Alaska Statute 36.90.210, on previously awarded public contracts (including contracts still in progress), have you ever failed to pay a subcontractor or material supplier within eight working days after receiving payment from the Owner (for projects occurring within the last 3 years)?

Yes       No      If yes, please attach a detailed explanation for each occurrence.

**B. EQUIPMENT**

1. Describe below, and/or as an attachment, the equipment you have available and intend to use for this project.

ITEM	QUANTITY	MAKE	MODEL	SIZE/CAPACITY	PRESENT MARKET VALUE

2. Do you propose to purchase any equipment for use on this project not listed on table B-1?

No     Yes    If YES, describe type, quantity, and approximate cost:

---



---



---



---

3. Do you propose to rent any equipment for this work not listed on table B-1?

No     Yes    If YES, describe type and quantity:

---



---



---



---



---

**SECTION 00370 - CONTRACTOR'S FINANCIAL RESPONSIBILITY**

4. Is your bid based on firm offers for all materials necessary for this project?

Yes  No If NO, please explain:

---

---

---

---

---

---

**I hereby certify that the above statements are true and complete.**

\_\_\_\_\_  
Contractor Signature

\_\_\_\_\_  
Name and Title of Person Signing

\_\_\_\_\_  
Signature

\_\_\_\_\_  
Date

**SECTION 00500 - AGREEMENT**

THIS AGREEMENT is between THE CITY AND BOROUGH OF JUNEAU (hereinafter called OWNER) and \_\_\_\_\_ (hereinafter called CONTRACTOR) OWNER and CONTRACTOR, in consideration of the mutual covenants hereinafter set forth, agree as follows:

**ARTICLE 1. WORK.**

CONTRACTOR shall complete the WORK as specified or as indicated under the Bid Schedule of the OWNER's Bid Documents entitled **Contract No. BE21-150, TONGASS BOULEVARD RECONSTRUCTION, PHASE 1**

The WORK covered in the Contract Documents includes reconstruction of Tongass Boulevard from the intersection of Trinity Drive to Dudley Street. Work generally includes clearing and grubbing, excavation, 2" minus shot rock with D-1 base course, storm drain improvements, replacement of existing water main, new water services, new fire hydrants, replacement of existing sewer main line, new sewer services, new sanitary sewer manholes, asphalt pavement, asphalt sidewalk, curb & gutter, mailboxes, traffic control signs, lighting, and other miscellaneous related WORK.

The WORK to be paid under this contract shall include the following: Total Bid as shown in Section 00310 - Bid Schedule.

**ARTICLE 2. CONTRACT COMPLETION TIME.**

The WORK must be completed by October 1, 2021, or 120 days from issuance of Notice to Proceed.

**ARTICLE 3. DATE OF AGREEMENT**

The date of this Agreement will be the date of the last signature on page three of this section.

**ARTICLE 4. LIQUIDATED DAMAGES.**

OWNER and the CONTRACTOR recognize that time is of the essence of this Agreement and that the OWNER will suffer financial loss if the WORK is not completed within the time specified in Article 2 herein, plus any extensions thereof allowed in accordance with Article 12 of the General Conditions. They also recognize the delays, expense, and difficulties involved in proving in a legal proceeding the actual damages suffered by the OWNER if the WORK is not completed on time. The amount of liquidated damages specified below is agreed to be a reasonable estimate based on all facts known as of the date of this Agreement.

<u>Work Description</u>	<u>Completion Date</u>	<u>Liquidated Damages</u>
Construction	October 1, 2021, or 120 Days from Notice to Proceed	\$1,000.00
Final Completion and Closeout	October 29, 2021	\$500.00

**ARTICLE 5. CONTRACT PRICE.**

OWNER shall pay CONTRACTOR for completion of the WORK in accordance with the Contract Documents in the amount set forth in the Bid Schedule. The CONTRACTOR agrees to accept as full and complete payment for all WORK to be done in this contract for: **Contract No. BE21-150, TONGASS BOULEVARD RECONSTRUCTION PHASE 1**, those Unit Price amounts as set forth in the Bid Schedule in the Contract Documents for this Project.

## SECTION 00500 - AGREEMENT

The total amount of this contract shall be \_\_\_\_\_ (\$ \_\_\_\_\_), except as adjusted in accordance with the provisions of the Bid Documents.

### ARTICLE 6. PAYMENT PROCEDURES.

CONTRACTOR shall submit Applications for Payment in accordance with Article 14 of the General Conditions. Applications for Payment will be processed by the ENGINEER as provided in the General Conditions.

Progress payments will be paid in full in accordance with Article 14 of the General Conditions until ninety (90) percent of the Contract Price has been paid. The remaining ten (10) percent of the Contract Price may be retained, in accordance with applicable Alaska State Statutes, until final inspection, completion, and acceptance of the Project by the OWNER.

### ARTICLE 7. CONTRACT DOCUMENTS.

The Contract Documents which comprise the entire Agreement between OWNER and CONTRACTOR concerning the WORK consist of this Agreement (pages 00500-1 to 00500-6, inclusive) and the following sections of the Contract Documents:

- Table of Contents (pages 00005-1 to 00005-2, inclusive)
- Notice Inviting Bids (pages 00030-1 to 00030-2, inclusive).
- Instructions to Bidders (pages 00100-1 to 00100-9, inclusive).
- Bid (pages 00300-1 to 00300-2, inclusive).
- Bid Schedule (pages 00310-1, inclusive).
- Bid Bond (page 00320-1, inclusive) or Bid Security.
- Subcontractor Report (pages 00360-1 to 00360-2, inclusive).
- Contractor Financial Responsibility (pages 00370-1 to 00370-3, inclusive).
- Performance Bond (pages 00610-1 to 00610-2, inclusive).
- Payment Bond (pages 00620-1 to 00620-2, inclusive).
- Insurance Certificate(s).
- General Conditions (pages 00700-1 to 00700-48, inclusive).
- Supplementary General Conditions (pages 00800-1 to 00800-5, inclusive).
- Alaska Labor Standards, Reporting, and Prevailing Wage Determination (page 00830-1).
- Permits, (page 00852-1).
- Standard Details (page 00853-1).
- Special Provisions (pages 1 to 69 inclusive)
- Drawings consisting of 23 sheets, as listed in the Table of Contents.
- Addenda numbers \_\_\_\_\_ to \_\_\_\_\_, inclusive.
- Change Orders which may be delivered or issued after the Date of the Agreement and which are not attached hereto.

There are no Contract Documents other than those listed in this Article 7. The Contract Documents may only be amended by Change Order as provided in Paragraph 3.3 of the General Conditions.

### ARTICLE 8. MISCELLANEOUS.

Terms used in this Agreement which are defined in Article 1 of the General Conditions will have the meanings indicated in the General Conditions.

**SECTION 00500 - AGREEMENT**

**ARTICLE 8. MISCELLANEOUS. (Cont'd.)**

No assignment by a party hereto of any rights under or interests in the Contract Documents will be binding on another party hereto without the written consent of the party sought to be bound; and specifically but without limitation monies that may become due and monies that are due may not be assigned without such consent (except to the extent that the effect of this restriction may be limited by law), and unless specifically stated to the contrary in any written consent to an assignment, no assignment will release or discharge the assignor from any duty or responsibility under the Contract Documents.

OWNER and CONTRACTOR each binds itself, its partners, successors, assigns and legal representatives to the other party hereto, its partners, successors, assigns and legal representatives in respect of all covenants, agreements and obligations contained in the Contract Documents. This Agreement shall be governed by the laws of the State of Alaska. Jurisdiction shall be in the State of Alaska, First Judicial District.

IN WITNESS WHEREOF, OWNER and CONTRACTOR have caused this Agreement to be executed on the date listed below by OWNER.

**OWNER:**

**CONTRACTOR:**

\_\_\_\_\_  
City and Borough of Juneau

\_\_\_\_\_  
(Company Name)

\_\_\_\_\_  
(Signature)

\_\_\_\_\_  
(Signature)

By: Duncan Rorie Watt, City & Borough Manager  
(Printed Name)

By: \_\_\_\_\_  
(Printed Name, Authority or Title)

Date: \_\_\_\_\_

CONTRACTOR Signature Date: \_\_\_\_\_

OWNER's address for giving notices:

CONTRACTOR's address for giving notices:

\_\_\_\_\_  
155 South Seward Street

\_\_\_\_\_

\_\_\_\_\_  
Juneau, Alaska 99801

\_\_\_\_\_

\_\_\_\_\_  
907-586-0873      907-586-4530  
(Telephone)      (Fax)

\_\_\_\_\_  
(Telephone)      (Fax)

\_\_\_\_\_  
(E-mail address)

Contractor License No. \_\_\_\_\_



SECTION 00500 - AGREEMENT

CERTIFICATE  
(if Corporation)

STATE OF )  
 ) SS:  
COUNTY OF )

I HEREBY CERTIFY that a meeting of the Board of Directors of the  
\_\_\_\_\_ a corporation existing under the laws of  
the State of \_\_\_\_\_, held on \_\_\_\_\_, 20\_\_\_\_, the following resolution  
was duly passed and adopted:

“RESOLVED, that \_\_\_\_\_, as \_\_\_\_\_ President  
of the Corporation, be and is hereby authorized to **execute the Agreement** with the CITY AND  
BOROUGH OF JUNEAU and this corporation and that the execution thereof, attested by the  
Secretary of the Corporation, and with the Corporate Seal affixed, shall be the official act and deed  
of this Corporation.”

I further certify that said resolution is now in full force and effect.

IN WITNESS WHEREOF, I have hereunto set my hand and affixed the official seal of the  
corporation this \_\_\_\_\_ day of \_\_\_\_\_, 20\_\_\_\_\_.

\_\_\_\_\_  
Secretary

(SEAL)

SECTION 00500 - AGREEMENT

CERTIFICATE  
(if Partnership)

STATE OF )  
 ) SS:  
COUNTY OF )

I HEREBY CERTIFY that a meeting of the Partners of the \_\_\_\_\_ a partnership existing under the laws of the State of \_\_\_\_\_, held on \_\_\_\_\_, 20\_\_\_\_, the following resolution was duly passed and adopted:

"RESOLVED, that \_\_\_\_\_, as \_\_\_\_\_ of the Partnership, be and is hereby authorized to **execute the Agreement** with the CITY AND BOROUGH OF JUNEAU and this partnership and that the execution thereof, attested by the \_\_\_\_\_ shall be the official act and deed of this Partnership."

I further certify that said resolution is now in full force and effect.

IN WITNESS WHEREOF, I have hereunto set my hand this \_\_\_\_\_, day of \_\_\_\_\_, 20\_\_\_\_\_.

\_\_\_\_\_  
Secretary

(SEAL)

SECTION 00500 - AGREEMENT

CERTIFICATE  
(if Joint Venture)

STATE OF )  
 ) SS:  
COUNTY OF )

I HEREBY CERTIFY that a meeting of the Principals of the

\_\_\_\_\_ a joint venture existing under the laws of the

State of \_\_\_\_\_, held on \_\_\_\_\_, 20\_\_\_\_, the following resolution was duly passed and adopted:

"RESOLVED, that \_\_\_\_\_, as \_\_\_\_\_ of the Joint Venture, be and is hereby authorized to **execute the Agreement** with the CITY AND BOROUGH OF JUNEAU and this joint venture and that the execution thereof, attested by the \_\_\_\_\_ shall be the official act and deed of this Joint Venture."

I further certify that said resolution is now in full force and effect.

IN WITNESS WHEREOF, I have hereunto set my hand this \_\_\_\_\_, day of \_\_\_\_\_, 20\_\_\_\_.

\_\_\_\_\_  
Secretary

(SEAL)

END OF SECTION

**SECTION 00610 - PERFORMANCE BOND**

KNOW ALL PERSONS BY THESE PRESENTS: That we \_\_\_\_\_  
(Name of Contractor)

\_\_\_\_\_ a \_\_\_\_\_  
(Corporation, Partnership, Individual)

hereinafter called "Principal" and \_\_\_\_\_  
(Surety)

of \_\_\_\_\_, State of \_\_\_\_\_ hereinafter called the "Surety," are held and  
firmly bound to the CITY AND BOROUGH of JUNEAU, ALASKA hereinafter called "OWNER,"  
(Owner) (City and State)

for the penal sum of \_\_\_\_\_

\_\_\_\_\_ dollars (\$ \_\_\_\_\_) in lawful money of the  
United States, for the payment of which sum well and truly to be made, we bind ourselves, our heirs, executors,  
administrators and successors, jointly and severally, firmly by these presents.

THE CONDITION OF THIS OBLIGATION is such that whereas, the CONTRACTOR has entered  
into a certain contract with the OWNER, the effective date of which is (CBJ Contracts Office to fill in effective  
date) \_\_\_\_\_, a copy of which is hereto attached and made a part hereof for the  
construction of:

**TONGASS BOULEVARD RECONSTRUCTION PHASE 1  
CBJ Contract No. BE21-150**

NOW, THEREFORE, if the Principal shall truly and faithfully perform its duties, all the undertakings,  
covenants, terms, conditions, and agreements of said contract during the original term thereof, and any  
extensions thereof, which may be granted by the OWNER, with or without notice to the Surety, and if it shall  
satisfy all claims and demands incurred under such contract, and shall fully indemnify and save harmless the  
OWNER from all costs and damages which it may suffer by reason of failure to do so, and shall reimburse and  
repay the OWNER all outlay and expense which the OWNER may incur in making good any default, then this  
obligation shall be void; otherwise to remain in full force and effect.

PROVIDED, FURTHER, that the said Surety, for value received hereby stipulates and agrees that no  
change, extension of time, alteration or addition to the terms of the contract or to the WORK to be performed  
thereunder or the specifications accompanying the same shall in any wise affect its obligation on this bond, and  
it does hereby waive notice of any such change, extension of time, alteration or addition to the terms of the  
contract or to the WORK or to the Specifications.

PROVIDED, FURTHER, that no final settlement between the OWNER and the Principal shall abridge  
the right of any beneficiary hereunder, whose claim may be unsatisfied.

**SECTION 00610 - PERFORMANCE BOND**

**TONGASS BOULEVARD RECONSTRUCTION PHASE 1  
CBJ Contract No. BE21-150**

IN WITNESS WHEREOF, this instrument is issued in two (2) identical counterparts, each one of which shall be deemed an original.

**CONTRACTOR:**

By: \_\_\_\_\_  
(Signature)

\_\_\_\_\_  
(Printed Name)

\_\_\_\_\_  
(Company Name)

\_\_\_\_\_  
(Mailing Address)

\_\_\_\_\_  
(City, State, Zip Code)

**SURETY:**

By: \_\_\_\_\_  
(Signature of Attorney-in-Fact)

Date Issued: \_\_\_\_\_

\_\_\_\_\_  
(Printed Name)

\_\_\_\_\_  
(Company Name)

\_\_\_\_\_  
(Mailing Address)

\_\_\_\_\_  
(City, State, Zip Code)

**(Affix SURETY'S SEAL)**

**NOTE: If CONTRACTOR is Partnership, all Partners must execute bond.**

**END OF SECTION**

**SECTION 00620 - PAYMENT BOND**

KNOW ALL PERSONS BY THESE PRESENTS: That we \_\_\_\_\_  
(Name of Contractor)

\_\_\_\_\_ a \_\_\_\_\_  
(Corporation, Partnership, Individual)

hereinafter called "Principal" and \_\_\_\_\_  
(Surety)

of \_\_\_\_\_, State of \_\_\_\_\_ hereinafter called the "Surety," are held and  
firmly bound to the CITY AND BOROUGH of JUNEAU, ALASKA hereinafter called "OWNER,"  
(Owner) (City and State)

for the penal sum of \_\_\_\_\_

\_\_\_\_\_ dollars (\$ \_\_\_\_\_) in lawful money of the  
United States, for the payment of which sum well and truly to be made, we bind ourselves, our heirs, executors,  
administrators and successors, jointly and severally, firmly by these presents.

THE CONDITION OF THIS OBLIGATION is such that whereas, the CONTRACTOR has entered  
into a certain contract with the OWNER, the effective date of which is (CBJ Contracts Office to fill in effective  
date) \_\_\_\_\_, a copy of which is hereto attached and made a part hereof for the  
construction of:

**TONGASS BOULEVARD RECONSTRUCTION PHASE 1  
CBJ Contract No. BE21-150**

NOW, THEREFORE, if the Principal shall promptly make payment to all persons, firms,  
Subcontractors, and corporations furnishing materials for, or performing labor in the prosecution of the WORK  
provided for in such contract, and any authorized extension or modification thereof, including all amounts due  
for materials, lubricants, oil, gasoline, coal and coke, repairs on machinery, equipment and tools, consumed or  
used in connection with the construction of such WORK, and all insurance premiums on said work, and for all  
labor performed in such WORK, whether by Subcontractor or otherwise, then this obligation shall be void;  
otherwise to remain in full force and effect.

PROVIDED, FURTHER, that the said Surety, for value received hereby stipulates and agrees that no  
change, extension of time, alteration or addition to the terms of the contract or to the work to be performed  
thereunder or the specifications accompanying the same shall in any wise affect its obligation on this bond, and  
it does hereby waive notice of any such change, extension of time, alteration or addition to the terms of the  
contract or to the WORK or to the Specifications.

PROVIDED, FURTHER, that no final settlement between the OWNER and the Principal shall abridge  
the right of any beneficiary hereunder, whose claim may be unsatisfied.

**SECTION 00620 - PAYMENT BOND**

**TONGASS BOULEVARD RECONSTRUCTION PHASE 1  
CBJ Contract No. BE21-150**

IN WITNESS WHEREOF, this instrument is issued in two (2) identical counterparts, each one of which shall be deemed an original.

**CONTRACTOR:**

By: \_\_\_\_\_  
(Signature)

\_\_\_\_\_  
(Printed Name)

\_\_\_\_\_  
(Company Name)

\_\_\_\_\_  
(Mailing Address)

\_\_\_\_\_  
(City, State, Zip Code)

**SURETY:**

By: \_\_\_\_\_  
(Signature of Attorney-in-Fact)

Date Issued: \_\_\_\_\_

\_\_\_\_\_  
(Printed Name)

\_\_\_\_\_  
(Company Name)

\_\_\_\_\_  
(Mailing Address)

\_\_\_\_\_  
(City, State, Zip Code)

**(Affix SURETY'S SEAL)**

**NOTE: If CONTRACTOR is Partnership, all Partners must execute bond.**

**END OF SECTION**

**SECTION 00700 - GENERAL CONDITIONS**

**TABLE OF CONTENTS**  
**(Revised 03-2003)**

**ARTICLE 1 DEFINITIONS** ..... 00700-5

**ARTICLE 2 PRELIMINARY MATTERS**

2.1 Delivery of Bonds/Insurance Certificates ..... 00700-9  
2.2 Copies of Documents ..... 00700-9  
2.3 Commencement of Contract Time; Notice to Proceed ..... 00700-9  
2.4 Starting the WORK ..... 00700-9  
2.5 Pre-construction Conference ..... 00700-9  
2.6 Finalizing CONTRACTOR Submittals..... 00700-9

**ARTICLE 3 CONTRACT DOCUMENTS: INTENT, AMENDING, REUSE**

3.1 Intent ..... 00700-10  
3.2 Order of Precedence of Contract Documents ..... 00700-10  
3.3 Amending and Supplementing Contract Documents..... 00700-11  
3.4 Reuse of Documents..... 00700-11

**ARTICLE 4 AVAILABILITY OF LANDS; PHYSICAL CONDITIONS; REFERENCE POINTS**

4.1 Availability of Lands ..... 00700-11  
4.2 Physical Conditions - Subsurface and Existing Structures ..... 00700-11  
4.3 Differing Site Conditions ..... 00700-12  
4.4 Physical Conditions - Underground Utilities ..... 00700-12  
4.5 Reference Points..... 00700-13  
4.6 Use of the CBJ/State Lemon Creek Gravel Pit ..... 00700-13

**ARTICLE 5 BONDS AND INSURANCE**

5.1 Performance, Payment and Other Bonds..... 00700-14  
5.2 Insurance ..... 00700-15

**ARTICLE 6 CONTRACTOR'S RESPONSIBILITIES**

6.1 Supervision and Superintendence..... 00700-17  
6.2 Labor, Materials, and Equipment ..... 00700-17  
6.3 Adjusting Progress Schedule..... 00700-18  
6.4 Substitutes or "Or Equal" Items..... 00700-19  
6.5 Concerning Subcontractors, Suppliers and Others ..... 00700-19  
6.6 Permits..... 00700-19  
6.7 Patent Fees and Royalties ..... 00700-20  
6.8 Laws and Regulations..... 00700-20



**SECTION 00700 - GENERAL CONDITIONS**

**ARTICLE 6 CONTRACTOR'S RESPONSIBILITIES (Cont'd.)**

6.9 Taxes ..... 00700-20  
6.10 Use of Premises ..... 00700-20  
6.11 Safety and Protection..... 00700-21  
6.12 Shop Drawings and Samples ..... 00700-22  
6.13 Continuing the WORK..... 00700-22  
6.14 Indemnification ..... 00700-22  
6.15 Contractor's Daily Reports..... 00700-23  
6.16 Assignment of Contract..... 00700-23  
6.17 Contractor's Responsibility for Utility Property and Services ..... 00700-23  
6.18 Operating Water System Valves ..... 00700-24  
6.19 CONTRACTOR's WORK Schedule Limitations ..... 00700-24

**ARTICLE 7 OTHER WORK**

7.1 Related WORK at Site ..... 00700-24  
7.2 Coordination..... 00700-25

**ARTICLE 8 OWNER'S RESPONSIBILITIES**

8.1 Communications..... 00700-25  
8.2 Payments ..... 00700-25  
8.3 Lands, Easements, and Surveys..... 00700-25  
8.4 Change Orders..... 00700-25  
8.5 Inspections and Tests..... 00700-25  
8.6 Suspension of WORK ..... 00700-25  
8.7 Termination of Agreement ..... 00700-25

**ARTICLE 9 ENGINEER'S STATUS DURING CONSTRUCTION**

9.1 OWNER 's Representative ..... 00700-25  
9.2 Visits to Site ..... 00700-25  
9.3 Project Representation..... 00700-26  
9.4 Clarifications and Interpretations..... 00700-28  
9.5 Authorized Variations in WORK ..... 00700-28  
9.6 Rejecting Defective WORK ..... 00700-28  
9.7 CONTRACTOR Submittals, Change Orders, and Payments ..... 00700-28  
9.8 Decisions on Disputes ..... 00700-28  
9.9 Limitation on Engineer's Responsibilities ..... 00700-29

**SECTION 00700 - GENERAL CONDITIONS**

**ARTICLE 10 CHANGES IN THE WORK**

10.1 General ..... 00700-30  
10.2 Allowable Quantity Variations ..... 00700-30

**ARTICLE 11 CHANGE OF CONTRACT PRICE**

11.1 General ..... 00700-31  
11.2 Costs Relating to Weather ..... 00700-31  
11.3 Cost of WORK (Based on Time and Materials) ..... 00700-32  
11.4 CONTRACTOR's Fee ..... 00700-34  
11.5 Excluded Costs ..... 00700-35

**ARTICLE 12 CHANGE OF CONTRACT TIME**

12.1 General ..... 00700-36  
12.2 Extensions of Time for Delay Due to Weather ..... 00700-36

**ARTICLE 13 WARRANTY AND GUARANTEE; TESTS AND INSPECTIONS;  
CORRECTION, REMOVAL, OR ACCEPTANCE OF DEFECTIVE WORK**

13.1 Warranty and Guarantee ..... 00700-37  
13.2 Access to WORK ..... 00700-37  
13.3 Tests and Inspections ..... 00700-37  
13.4 OWNER May Stop the WORK ..... 00700-38  
13.5 Correction or Removal of Defective WORK ..... 00700-38  
13.6 One Year Correction Period ..... 00700-39  
13.7 Acceptance of Defective WORK ..... 00700-39

**ARTICLE 14 PAYMENTS TO CONTRACTOR AND COMPLETION**

14.1 Schedule of Values (Lump Sum Price Breakdown) ..... 00700-39  
14.2 Unit Price Bid Schedule ..... 00700-39  
14.3 Application for Progress Payment ..... 00700-39  
14.4 CONTRACTOR's Warranty of Title ..... 00700-40  
14.5 Review of Applications for Progress Payment ..... 00700-40  
14.6 Partial Utilization ..... 00700-41  
14.7 Substantial Completion ..... 00700-41  
14.8 Final Application for Payment ..... 00700-41  
14.9 Final Payment and Acceptance ..... 00700-42  
14.10 Release of Retainage and Other Deductions ..... 00700-42  
14.11 CONTRACTOR's Continuing Obligation ..... 00700-42  
14.12 Final Payment Terminates Liability of OWNER ..... 00700-43

**SECTION 00700 - GENERAL CONDITIONS**

**ARTICLE 15 SUSPENSION OF WORK AND TERMINATION**

15.1 Suspension of WORK by OWNER..... 00700-43  
15.2 Termination of Agreement by OWNER (CONTRACTOR Default)..... 00700-43  
15.3 Termination of Agreement by OWNER (For Convenience) ..... 00700-43  
15.4 Termination of Agreement by CONTRACTOR..... 00700-44

**ARTICLE 16 MISCELLANEOUS**

16.1 Giving Notice ..... 00700-44  
16.2 Rights In and Use of Materials Found on the WORK..... 00700-44  
16.3 Right to Audit..... 00700-45  
16.4 Archaeological or Historical Discoveries ..... 00700-45  
16.5 Construction Over or Adjacent to Navigable Waters ..... 00700-45  
16.6 Gratuity and Conflict of Interest..... 00700-45  
16.7 Suits of Law Concerning the WORK..... 00700-46  
16.8 Certified Payrolls..... 00700-46  
16.9 Prevailing Wage Rates ..... 00700-46  
16.10 Employment Reference ..... 00700-47  
16.11 Cost Reduction Incentive ..... 00700-47

## SECTION 00700 - GENERAL CONDITIONS

### ARTICLE 1 DEFINITIONS

Wherever used in these General Conditions or in the Contract Documents the following terms have the meanings indicated which are applicable to both the singular and plural thereof. Where an entire word is capitalized in the definitions and is found not capitalized in the Contract Documents it has the ordinary dictionary definition.

Addenda - Written or graphic instruments issued prior to the opening of Bids which make additions, deletions, or revisions to the Contract Documents.

Agreement - The written contract between the OWNER and the CONTRACTOR covering the WORK to be performed; other documents are attached to the Agreement and made a part thereof as provided therein.

Application for Payment - The form furnished by the ENGINEER which is to be used by the CONTRACTOR to request progress or final payment and which is to be accompanied by such supporting documentation as is required by the Contract Documents.

Asbestos - Any material that contains more than one percent asbestos and is friable or is releasing asbestos fibers into the air above current action levels established by the United States Occupational Safety and Health Administration.

Bid - The offer or proposal of the Bidder submitted on the prescribed form setting forth the price or prices for the WORK.

Bonds - Bid, Performance, and Payment Bonds and other instruments which protect against loss due to inability or refusal of the CONTRACTOR to perform its contract.

CBJ Project Manager - The authorized representative of the City and Borough of Juneau Engineering Department, as OWNER, who is responsible for administration of the contract.

Change Order - A document recommended by the ENGINEER, which is signed by the CONTRACTOR and the OWNER and authorizes an addition, deletion, or revision in the WORK, or an adjustment in the Contract Price or the Contract Time, issued on or after the Effective Date of the Agreement.

Contract Documents - The Table of Contents, Notice Inviting Bids, Instructions to Bidders, Bid Forms (including the Bid, Bid Schedule(s), Information Required of Bidder, Bid Bond, and all required certificates and affidavits), Agreement, Performance Bond, Payment Bond, General Conditions, Supplementary General Conditions, Technical Specifications, Drawings, Permits, and all Addenda, and Change Orders executed pursuant to the provisions of the Contract Documents.

Contract Price - The total monies payable by the OWNER to the CONTRACTOR under the terms and conditions of the Contract Documents.

Contract Time - The number of successive calendar Days stated in the Contract Documents for the completion of the WORK.

CONTRACTOR - The individual, partnership, corporation, joint-venture or other legal entity with whom the OWNER has executed the Agreement.

## SECTION 00700 - GENERAL CONDITIONS

Day - A calendar day of 24 hours measured from midnight to the next midnight.

Defective WORK - WORK that is unsatisfactory, faulty, or deficient; or that does not conform to the Contract Documents; or that does not meet the requirements of any inspection, reference standard, test, or approval referred to in the Contract Documents; or WORK that has been damaged prior to the ENGINEER's recommendation of final payment.

Drawings - The Drawings, plans, maps, profiles, diagrams, and other graphic representations which indicate the character, location, nature, extent, and scope of the WORK and which have been prepared by the ENGINEER and are referred to in the Contract Documents. Shop Drawings are not within the meaning of this paragraph.

Effective Date of the Agreement - The date indicated in the Agreement on which it becomes effective, but if no such date is indicated it means the date on which the Agreement is signed and delivered by the last of the two parties to sign and deliver.

Engineer of Record - The individual, partnership, corporation, joint-venture or other legal entity named as such in the Contract Documents.

ENGINEER - The ENGINEER is the firm or person(s) selected by the City and Borough of Juneau (CBJ) to perform the duties of project inspection and management. CBJ will inform the CONTRACTOR of the identity of the ENGINEER at or before the Notice to Proceed.

Field Order - A written order issued by the ENGINEER which may or may not involve a change in the WORK.

General Requirements - Division 1 of the Technical Specifications.

Hazardous Waste - The term Hazardous Waste shall have the meaning provided in Section 1004 of the Solid Waste Disposal Act (42 USC Section 9603) as amended from time to time.

Holidays - The CBJ legal holidays occur on:

1. New Year's Day - January 1
2. Martin Luther King's Birthday - Third Monday in January
3. President's Day - Third Monday in February
4. Seward's Day - Last Monday in March
5. Memorial Day - Last Monday in May
6. Independence Day - July 4
7. Labor Day - First Monday in September
8. Alaska Day - October 18
9. Veteran's Day - November 11
10. Thanksgiving Day - Fourth Thursday and the following Friday in November
11. Christmas Day - December 25

If any holiday listed above falls on a Saturday, Saturday and the preceding Friday are both legal holidays. If the holiday should fall on a Sunday, Sunday and the following Monday are both legal holidays.

## SECTION 00700 - GENERAL CONDITIONS

Inspector - The authorized representative of the ENGINEER assigned to make detailed inspections for conformance to the Contract Documents. Any reference to the Resident Project Representative in this document shall mean the Inspector.

Laws and Regulations; Laws or Regulations - Any and all applicable laws, rules, regulations, ordinances, codes, and/or orders of any and all governmental bodies, agencies, authorities and courts having jurisdiction.

Mechanic's Lien - A form of security, an interest in real property, which is held to secure the payment of an obligation. When referred to in these Contract Documents, "Mechanic's Lien" or "lien" means "Stop Notice".

Milestone - A principal event specified in the Contract Documents relating to an intermediate completion date of a portion of the WORK, or a period of time within which the portion of the WORK should be performed prior to Substantial Completion of all the WORK.

Notice of Award - The written notice by the OWNER to the apparent successful bidder stating that the apparent successful bidder has complied with all conditions for award of the contract.

Notice of Completion - A form signed by the ENGINEER and the CONTRACTOR recommending to the OWNER that the WORK is Substantially Complete and fixing the date of Substantial Completion. After acceptance of the WORK by the OWNER's governing body, the form is signed by the OWNER and filed with the County Recorder. This filing starts the 30-day lien filing period on the WORK.

Notice to Proceed - The written notice issued by the OWNER to the CONTRACTOR authorizing the CONTRACTOR to proceed with the WORK and establishing the date of commencement of the Contract Time.

Notice of Intent to Award - The written notice by the OWNER to the apparent successful bidder stating that upon compliance by the apparent successful bidder with the requirements listed therein, within the time specified, the OWNER will enter into an Agreement.

OWNER - The City and Borough of Juneau (CBJ), acting through its legally designated officials, officers, or employees.

Partial Utilization - Use by the OWNER or a substantially completed part of the WORK for the purpose for which it is intended prior to Substantial Completion of all the WORK.

PCB's - Polychlorinated biphenyls.

PERMITTEE – See definition for CONTRACTOR.

Petroleum - Petroleum, including crude oil or any fraction thereof which is liquid at standard conditions of temperature and pressure (60 degrees Fahrenheit and 14.7 pounds per square inch absolute), such as oil, petroleum, fuel oil, oil sludge, oil refuse, gasoline, kerosene, and oil mixed with other non-Hazardous Wastes and crude oils.

Project - The total construction of which the WORK to be provided under the Contract Documents may be the whole, or a part as indicated elsewhere in the Contract Documents.

## SECTION 00700 - GENERAL CONDITIONS

Radioactive Material - Source, special nuclear, or byproduct material as defined by the Atomic Energy Act of 1954 (42 USC Section 2011 et seq.) as amended from time to time.

Shop Drawings - All Drawings, diagrams, illustrations, schedules and other data which are specifically prepared by or for the CONTRACTOR and submitted by the CONTRACTOR, to the ENGINEER, to illustrate some portion of WORK.

Specifications - Same definition as "Technical Specifications" hereinafter.

Stop Notice - A legal remedy for Subcontractors and suppliers who contribute to public works, but who are not paid for their WORK, which secures payment from construction funds possessed by the OWNER. For public property, the Stop Notice remedy is designed to substitute for mechanic's lien rights.

Sub-Consultant - The individual, partnership, corporation, joint-venture or other legal entity having a direct contract with ENGINEER, or with any of its Consultants to furnish services with respect to the Project.

Subcontractor - An individual, partnership, corporation, joint-venture or other legal entity having a direct contract with the CONTRACTOR, or with any of its Subcontractors, for the performance of a part of the WORK at the site.

Substantial Completion - Refers to when the WORK has progressed to the point where, in the opinion of the ENGINEER as evidenced by Notice of Completion as applicable, it is sufficiently complete, in accordance with the Contract Documents, so that the WORK can be utilized for the purposes for which it is intended; or if no such notice is issued, when final payment is due in accordance with Paragraph 14.8. The terms "substantially complete" and "substantially completed" as applied to any WORK refer to substantial completion thereof.

Supplementary General Conditions (SGC) - The part of the Contract Documents which make additions, deletions, or revisions to these General Conditions.

Supplier - A manufacturer, fabricator, supplier, distributor, materialman, or vendor.

Technical Specifications - Divisions 1 through 16 of the Contract Documents consisting of the General Requirements and written technical descriptions of products and execution of the WORK.

Underground Utilities - All pipelines, conduits, ducts, cables, wires, manholes, vaults, tanks, tunnels, or other such facilities or attachments, and any encasements containing such facilities which have been installed underground to furnish any of the following services or materials: water, sewage and drainage removal, electricity, gases, steam, liquid petroleum products, telephone or other communications, cable television, traffic, or other control systems.

WORK, Work - The entire completed construction or the various separately identifiable parts thereof required to be furnished under the Contract Documents. WORK is the result of performing, or furnishing labor and furnishing and incorporating materials and equipment into the construction, and performing or furnishing services and furnishing documents, all as required by the Contract Documents.

## SECTION 00700 - GENERAL CONDITIONS

### ARTICLE 2 PRELIMINARY MATTERS

- 2.1 DELIVERY OF BONDS/INSURANCE CERTIFICATES. When the CONTRACTOR delivers the signed Agreements to the OWNER, the CONTRACTOR shall also deliver to the OWNER such Bonds and Insurance Policies and Certificates as the CONTRACTOR may be required to furnish in accordance with the Contract Documents.
- 2.2 COPIES OF DOCUMENTS. The OWNER shall furnish to the CONTRACTOR the required number of copies of the Contract Documents specified in the Supplementary General Conditions.
- 2.3 COMMENCEMENT OF CONTRACT TIME; NOTICE TO PROCEED. The Contract Time will start to run on the commencement date stated in the Notice to Proceed.
- 2.4 STARTING THE WORK
- A. The CONTRACTOR shall begin to perform the WORK within 10 days after the commencement date stated in the Notice to Proceed, but no WORK shall be done at the site prior to said commencement date.
  - B. Before undertaking each part of the WORK, the CONTRACTOR shall carefully study and compare the Contract Documents and check and verify pertinent figures shown thereon and all applicable field measurements. The CONTRACTOR shall promptly report in writing to the ENGINEER any conflict, error, or discrepancy which the CONTRACTOR may discover and shall obtain a written interpretation or clarification from the ENGINEER before proceeding with any WORK affected thereby.
  - C. The CONTRACTOR shall submit to the ENGINEER for review those documents called for under Section 01300 - CONTRACTOR Submittals in the General Requirements.
- 2.5 PRE-CONSTRUCTION CONFERENCE. The CONTRACTOR is required to attend a Pre-Construction Conference. This conference will be attended by the ENGINEER and others as appropriate in order to discuss the WORK in accordance with the applicable procedures specified in the General Requirements, Section 01010 - Summary of WORK in the General Requirements.
- 2.6 FINALIZING CONTRACTOR SUBMITTALS. At least 7 days before submittal of the first Application for Payment a conference attended by the CONTRACTOR, the ENGINEER and others as appropriate will be held to finalize the initial CONTRACTOR submittals in accordance with the General Requirements. As a minimum the CONTRACTOR's representatives should include the project manager and schedule expert. The CONTRACTOR should plan on this meeting taking no less than 8 hours. If the submittals are not finalized at the end of the meeting, additional meetings will be held so that the submittals can be finalized prior to the submittal of the first application for payment. No application for payment will be processed until CONTRACTOR submittals are finalized.



## SECTION 00700 - GENERAL CONDITIONS

### ARTICLE 3 CONTRACT DOCUMENTS: INTENT, AMENDING, REUSE

#### 3.1 INTENT

- A. The Contract Documents comprise the entire Agreement between the OWNER and the CONTRACTOR concerning the WORK. The Contract Documents shall be construed as a whole in accordance with Alaska Law.
- B. It is the intent of the Contract Documents to describe the WORK, functionally complete, to be constructed in accordance with the Contract Documents. Any work, materials, or equipment that may reasonably be inferred from the Contract Documents as being required to produce the intended result shall be supplied whether or not specifically called for. When words or phrases which have a well-known technical or construction industry or trade meaning are used to describe work, materials, or equipment such words or phrases shall be interpreted in accordance with that meaning, unless a definition has been provided in Article 1 of the General Conditions. Reference to standard specifications, manuals, or codes of any technical society, organization, or association, or to the Laws or Regulations of any governmental authority, whether such reference be specific or by implication, shall mean the latest standard specification, manual, code, or Laws or Regulations in effect at the time of opening of Bids, except as may be otherwise specifically stated. However, no provision of any referenced standard specification, manual, or code (whether or not specifically incorporated by reference in the Contract Documents) shall be effective to change the duties and responsibilities of the OWNER, the CONTRACTOR, or the ENGINEER or any of their consultants, agents, or employees from those set forth in the Contract Documents.
- C. If, during the performance of the WORK, CONTRACTOR discovers any conflict, error, ambiguity or discrepancy within the Contract Documents or between the Contract Documents and any provision of any such Law or Regulation applicable to the performance of the WORK or of any such standard, specification, manual or code or of any instruction of any Supplier referred to in paragraph 6.5, the CONTRACTOR shall report it to the ENGINEER in writing at once, and the CONTRACTOR shall not proceed with the WORK affected thereby (except in an emergency as authorized by the ENGINEER) until a clarification field order, or Change Order to the Contract Documents has been issued.

#### 3.2 ORDER OF PRECEDENCE OF CONTRACT DOCUMENTS

- A. In resolving conflicts resulting from, errors, or discrepancies in any of the Contract Documents, the order of precedence shall be as follows:
  - 1. Permits from other agencies as may be required by law, excepting the definition of "PERMITEE" in these permits.
  - 2. Field Orders
  - 3. Change Orders
  - 4. ENGINEER's written interpretations and clarifications.
  - 5. Agreement
  - 6. Addenda
  - 7. CONTRACTOR's Bid (Bid Form)
  - 8. Supplementary General Conditions
  - 9. Notice Inviting Bids

## SECTION 00700 - GENERAL CONDITIONS

10. Instructions to Bidders
11. General Conditions
12. Technical Specifications
13. Drawings

B. With reference to the Drawings the order of precedence is as follows:

1. Figures govern over scaled dimensions
2. Detail Drawings govern over general Drawings
3. Addenda/ Change Order drawings govern over Contract Drawings
4. Contract Drawings govern over standard drawings

3.3 AMENDING AND SUPPLEMENTING CONTRACT DOCUMENTS. The Contract Documents may be amended to provide for additions, deletions, and revisions in the WORK or to modify the terms and conditions thereof by a Change Order (pursuant to Article 10 CHANGES IN THE WORK).

3.4 REUSE OF DOCUMENTS. Neither the CONTRACTOR, nor any Subcontractor or Supplier, nor any other person or organization performing any of the WORK under a contract with the OWNER shall have or acquire any title to or ownership rights in any of the Drawings, Technical Specifications, or other documents used on the WORK, and they shall not reuse any of them on the extensions of the Project or any other project without written consent of the OWNER.

### ARTICLE 4 AVAILABILITY OF LANDS; PHYSICAL CONDITIONS; REFERENCE POINTS

4.1 AVAILABILITY OF LANDS. The OWNER shall furnish, as indicated in the Contract Documents, the lands upon which the WORK is to be performed, rights-of-way and easements for access thereto, and such other lands which are designated for the use of the CONTRACTOR. Easements for permanent structures or permanent changes in existing facilities will be obtained and paid for by the OWNER, unless otherwise provided in the Contract Documents. Nothing contained in the Contract Documents shall be interpreted as giving the CONTRACTOR exclusive occupancy of the lands or rights-of-way provided. The CONTRACTOR shall provide for all additional lands and access thereto that may be required for temporary construction facilities or storage of materials and equipment; provided, that the CONTRACTOR shall not enter upon nor use any property not under the control of the OWNER until a written temporary construction easement, lease or other appropriate agreement has been executed by the CONTRACTOR and the property owner, and a copy of said agreement furnished to the ENGINEER prior to said use; and, neither the OWNER nor the ENGINEER shall be liable for any claims or damages resulting from the CONTRACTOR's unauthorized trespass or use of any such properties.

#### 4.2 PHYSICAL CONDITIONS - SUBSURFACE AND EXISTING STRUCTURES

A. Explorations and Reports. Reference is made to SGC 4.2 Physical Conditions of the Supplementary General Conditions for identification of those reports of explorations and tests of sub-surface conditions at the site that have been utilized by the ENGINEER in the preparation of the Contract Documents. The CONTRACTOR may rely upon the accuracy of the technical data contained in such reports, however, reports are not to be considered complete or comprehensive and nontechnical data, interpretations, and opinions contained in such reports are not to be relied on by the CONTRACTOR. The CONTRACTOR is

## SECTION 00700 - GENERAL CONDITIONS

responsible for any further explorations or tests that may be necessary and any interpretation, interpolation, or extrapolation that it makes of any information shown in such reports.

- B. Existing Structures. Reference is made to SGC 4.2 Physical Conditions of the Supplementary General Conditions for identification of those drawings of physical conditions in or relating to existing surface and subsurface structures (except Underground Utilities referred to in Paragraph 4.4 herein) which are at or contiguous to the site that have been utilized by the ENGINEER in the preparation of the Contract Documents. The CONTRACTOR may rely upon the accuracy of the technical data contained in such drawings, however, nontechnical data, interpretations, and opinions contained in such drawings are not to be relied on by the CONTRACTOR. The CONTRACTOR is also responsible for any interpretation, interpolation, or extrapolation that it makes of any information shown in such drawings.

### 4.3 DIFFERING SITE CONDITIONS

- A. The CONTRACTOR shall promptly upon discovery (but in no event later than 14 days thereafter) and before the following conditions are disturbed, notify the ENGINEER, in writing of any:
  - 1. Material that the CONTRACTOR believes may be material that is hazardous waste, as defined in Article 1 of these General Conditions, or asbestos, PCB's, petroleum or any other substance or material posing a threat to human or to the environment.
  - 2. Subsurface or latent physical conditions at the site differing from those indicated.
  - 3. Unknown physical conditions at the site of any unusual nature, different materially from those ordinarily encountered and generally recognized as inherent in WORK of the character provided for in the contract.
- B. The OWNER shall promptly investigate the conditions, and if it finds that the conditions do materially so differ, or do involve hazardous waste, and cause a decrease or increase in the CONTRACTOR's cost of, or the time required for, performance of any part of the WORK shall issue a Change Order under the procedures described in the contract.
- C. In the event that a dispute arises between the OWNER and the CONTRACTOR whether the conditions materially differ, or involved hazardous waste or other materials listed above, or cause a decrease or increase in the CONTRACTOR's cost of, or time required for, performance of any part of the WORK, the CONTRACTOR shall not be excused from any scheduled completion date provided for by the contract, but shall proceed with all WORK to be performed under the contract. The CONTRACTOR shall retain any and all rights provided either by contract or by Law which pertain to the resolution of disputes and protests between the contracting parties.

### 4.4 PHYSICAL CONDITIONS - UNDERGROUND UTILITIES

- A. Indicated. The information and data indicated in the Contract Documents with respect to existing Underground Utilities at or contiguous to the site are based on information and data furnished to the OWNER or the ENGINEER by the owners of such Underground Utilities or by others. Unless it is expressly provided in the Supplementary General Conditions and/or Section 01530 - Protection and Restoration of Existing Facilities of the General Requirements, the OWNER and the ENGINEER shall not be responsible for the accuracy or

## SECTION 00700 - GENERAL CONDITIONS

completeness of any such information or data, and the CONTRACTOR shall have full responsibility for reviewing and checking all such information and data, for locating all Underground Utilities indicated in the Contract Documents, for coordination of the WORK with the owners of such Underground Utilities during construction, for the safety and protection thereof and repairing any damage thereto resulting from the WORK, the cost of which will be considered as having been included in the Contract Price.

- B. Not Indicated. If an Underground Utility is uncovered or revealed at or contiguous to the site which was not indicated in the Contract Documents and which the CONTRACTOR could not reasonably have been expected to be aware of, the CONTRACTOR shall identify the owner of such Underground Utility and give written notice thereof to that owner and shall notify the ENGINEER in accordance with the requirements of the Supplementary General Conditions and Section 01530 - Protection and Restoration of Existing Facilities of the General Requirements.

### 4.5 REFERENCE POINTS

- A. The ENGINEER will provide one bench mark, near or on the site of the WORK, and will provide two points near or on the site to establish a base line for use by the CONTRACTOR for alignment control. Unless otherwise specified in the General Requirements, the CONTRACTOR shall furnish all other lines, grades, and bench marks required for proper execution of the WORK.
- B. The CONTRACTOR shall preserve all bench marks, stakes, and other survey marks, and in case of their removal or destruction by its own employees or by its Subcontractor's employees, the CONTRACTOR shall be responsible for the accurate replacement of such reference points by personnel qualified under the Alaska Statute governing the licensing of Architects, Engineers, and Land Surveyors.

### 4.6 USE OF THE CBJ/STATE LEMON CREEK GRAVEL PIT

- A. On City and Borough of Juneau (CBJ) construction projects, the CBJ may make unclassified material available to CONTRACTORs, from the CBJ/State Lemon Creek gravel pit, at a rate less than charged other customers. CONTRACTORs are not required to use material from the CBJ/State pit and the CBJ makes no guarantee as to the quantity or quality of the available material. For this Project, contact Alec Venechuk, CBJ Material Source Manager, at (907) 586-0874 for the current material rates.
- B. CONTRACTORs proposing to use gravel from the CBJ/State pit are required to be in good standing for all amounts owed to the CBJ, for previous gravel operations, prior to submitting a mining plan for approval. CONTRACTORs using the pit must comply with Allowable Use Permit USE 2008-00061. Failure to meet these requirements, if so subject, shall be sufficient reason to deny use of the CBJ/State pit as a gravel source. To determine if your company is subject to these requirements, contact the CBJ Engineering Department, Gravel Pit Management, at (907) 586-0874.
- C. CONTRACTORs deciding to use material from the CBJ/State pit shall provide an Individual Mining Plan prepared by a professional engineer registered in the State of Alaska. The Individual Mining Plan must be reviewed and approved by the CBJ, prior to commencing

## SECTION 00700 - GENERAL CONDITIONS

operations within the pit. CONTRACTORS shall also secure a Performance Bond to ensure compliance with contract provisions, including any Individual Mining Plan stipulations. The bond shall remain in full force and effect until a release is obtained from the CBJ.

- D. If CONTRACTOR operations for a project do not exceed 500 tons of material, the CONTRACTOR will not be required to provide an Individual Mining Plan prepared by an engineer. However, the CONTRACTOR must submit an Individual Mining Plan that is in compliance with Allowable Use Permit USE 2008-00061 for gravel extraction within the CBJ/State pit. The CONTRACTOR must contact the CBJ Engineering Department for conditions for the extraction.
- E. CONTRACTORS using the CBJ material may do primary dry separation (screening) of materials within the pit. Crushing and washing of material will not be allowed. CONTRACTORS shall account for placement of materials removed from the pit. The CBJ may require CONTRACTORS to cross-check weight tickets, submit to an audit, or participate in other measures required by the CBJ to ensure accountability. Unprocessed overburden removed from the pit will not be weighed. All other material mined will be weighed at the CBJ scale. CONTRACTORS will be responsible for loading and/or screening their own material. If asphalt pavement is removed as part of the WORK, CONTRACTORS shall dispose of the material at a to-be-specified location within the pit area, as directed by the CBJ Project Manager.
- F. The gravel pit overhead charge shall be paid to the CBJ by the CONTRACTOR within 60 days after removal of all materials from the pit and prior to requesting and/or receiving final payment. Upon completion of each excavation CONTRACTORS shall notify the CBJ, in writing, in sufficient time to perform a field-compliance examination prior to vacating the pit. Any significant deviation from the stipulations of the Individual Mining Plan identified during the field inspection shall be corrected by the CONTRACTOR prior to release of the bond. A signed release from CBJ will be required prior to releasing the CONTRACTOR's bond.
- G. If asphalt pavement is removed as part of this WORK, the CONTRACTOR shall dispose of the material at the location designated as the Asphalt Storage Facility, or as directed by the ENGINEER.
- H. The CBJ/State pit is a seasonal operation. The hours of operation are from 7:00 a.m. to 6:00 p.m., Monday through Friday, from April 1 through October 15 of the year. CONTRACTORS may obtain gravel on weekends, or during the off-season, by applying for a separate agreement with the City and Borough of Juneau Engineering Department. The CONTRACTOR will be responsible for any additional costs incurred during weekend or off-season operations at the gravel pit.
- I. All Contractors/Equipment Operators using the CBJ/State Pit shall be in compliance with Federal Mine Safety and Health Administration regulations for quarry and gravel operations.

## ARTICLE 5 BONDS AND INSURANCE

### 5.1 PERFORMANCE, PAYMENT, AND OTHER BONDS

## SECTION 00700 - GENERAL CONDITIONS

- A. The CONTRACTOR shall furnish, when required, Performance and Payment Bonds on forms provided by the CBJ for the penal sums of 100% of the amount of the Bid award. The surety on each bond may be any corporation or partnership authorized to do business in the State of Alaska as an insurer under AS 21.09. These bonds shall remain in effect for 12 months after the date of final payment and until all obligations and liens under this contract have been satisfied. The CONTRACTOR shall also furnish such other Bonds as are required by the Supplementary General Conditions. All Bonds shall be in the form prescribed by the Contract Documents except as provided otherwise by Laws or Regulations, and shall be executed by such sureties as are named in the current list of "Companies Holding Certificates of Authority as Acceptable Sureties on Federal Bonds and as Acceptable Reinsuring Companies" as published in Circular 570 (amended) by the Audit Staff, Bureau of Government Financial Operations, U.S. Treasury Department. All Bonds signed by an agent must be accompanied by a certified copy of such agent's authority to act.
- B. If the surety on any Bond furnished by the CONTRACTOR is declared bankrupt or becomes insolvent or its right to do business is terminated in any state where any part of the WORK is located, the CONTRACTOR shall within 7 days thereafter substitute another Bond and Surety, which must be acceptable to the OWNER.
- C. All Bonds required by the Contract Documents to be purchased and maintained by CONTRACTOR shall be obtained from surety companies that are duly licensed or authorized in the State of Alaska to issue Bonds for the limits so required. Such surety companies shall also meet such additional requirements and qualifications as may be provided in the Supplementary General Conditions. The City Engineer may, on behalf of the OWNER, notify the surety of any potential default or liability.

### 5.2 INSURANCE

- A. The CONTRACTOR shall purchase and maintain the insurance required under this paragraph. Such insurance shall include the specific coverages set out herein and be written for not less than the limits of liability and coverages provided in the Supplementary General Conditions, or required by law, whichever are greater. All insurance shall be maintained continuously during the life of the Agreement up to the date of Final Completion and at all times thereafter when the CONTRACTOR may be correcting, removing, or replacing Defective WORK in accordance with Paragraph 13.6, but the CONTRACTOR's liabilities under this Agreement shall not be deemed limited in any way to the insurance coverage required.
- B. All insurance required by the Contract Documents to be purchased and maintained by the CONTRACTOR shall be obtained from insurance companies that are duly licensed or authorized in the State of Alaska to issue insurance policies for the limits and coverages so required. Such insurance companies shall have a current Best's Rating of at least an "A" (Excellent) general policy holder's rating and a Class VII financial size category and shall also meet such additional requirements and qualifications as may be provided in the Supplementary General Conditions.
- C. The CONTRACTOR shall furnish the OWNER with certificates showing the type, amount, class of operations covered, effective dates and dates of expiration of policies. All of the policies of insurance so required to be purchased and maintained (or the certificates or other

## SECTION 00700 - GENERAL CONDITIONS

evidence thereof) shall contain a provision or endorsement that the coverage afforded will not be cancelled, reduced in coverage, or renewal refused until at least 30 days' prior written notice has been given to the OWNER by certified mail. All such insurance required herein (except for Workers' Compensation and Employer's Liability) shall name the OWNER, its Consultants and subconsultants and their officers, directors, agents, and employees as "additional insureds" under the policies. The CONTRACTOR shall purchase and maintain the following insurance:

1. Workers' Compensation and Employer's Liability. This insurance shall protect the CONTRACTOR against all claims under applicable state workers' compensation laws. The CONTRACTOR shall also be protected against claims for injury, disease, or death of employees which, for any reason, may not fall within the provisions of a Workers' Compensation law. This policy shall include an "all states" endorsement. The CONTRACTOR shall require each Subcontractor similarly to provide Workers' Compensation Insurance for all of the latter's employees to be engaged in such WORK unless such employees are covered by the protection afforded by the CONTRACTOR's Workers' Compensation Insurance. In case any class of employees is not protected, under the Workers' Compensation Statute, the CONTRACTOR shall provide and shall cause each Subcontractor to provide adequate employer's liability insurance for the protection of such of its employees as are not otherwise protected.
2. Commercial General Liability. This insurance shall be written in comprehensive form and shall protect the CONTRACTOR against all claims arising from injuries to persons other than its employees or damage to property of the OWNER or others arising out of any act or omission of the CONTRACTOR or its agents, employees, or Subcontractors. The policy shall contain no exclusions for any operations within the scope of this contract.
3. Comprehensive Automobile Liability. This insurance shall be written in comprehensive form and shall protect the CONTRACTOR against all claims for injuries to members of the public and damage to property of others arising from the use of motor vehicles, and shall cover operation on or off the site of all motor vehicles licensed for highway use, whether they are owned, non-owned, or hired. Coverage for hired motor vehicles should include endorsement covering liability assumed under this Agreement.
4. Subcontractor's Commercial General Liability Insurance and Commercial Automobile Liability Insurance. The CONTRACTOR shall either require each of its Subcontractors to procure and to maintain Subcontractor's Commercial General Liability and Property Damage Insurance and Vehicle Liability Insurance of the type and in the amounts specified in the Supplementary General Conditions or insure the activities of its Subcontractors in the CONTRACTOR's own policy, in like amount.
5. Builder's Risk. This insurance shall be of the "all risks" type, shall be written in completed value form, and shall protect the CONTRACTOR, the OWNER, and the ENGINEER, against risks of damage to buildings, structures, and materials and equipment. The amount of such insurance shall be not less than the insurable value of the WORK at completion. Builder's risk insurance shall provide for losses to be payable to the CONTRACTOR and the OWNER, as their interests may appear. The policy shall contain a provision that in the event of payment for any loss under the coverage provided, the insurance company shall have no rights of recovery against the

## SECTION 00700 - GENERAL CONDITIONS

CONTRACTOR, the OWNER, and the ENGINEER. The Builder's Risk policy shall insure against all risks of direct physical loss or damage to property from any external cause including flood and earthquake. Allowable exclusions, if any, shall be as specified in the Supplementary General Conditions.

### ARTICLE 6 CONTRACTOR'S RESPONSIBILITIES

#### 6.1 SUPERVISION AND SUPERINTENDENCE

- A. The CONTRACTOR shall supervise, inspect, and direct the WORK competently and efficiently, devoting such attention thereto and applying such skills and expertise as may be necessary to perform the WORK in accordance with the Contract Documents. The CONTRACTOR shall be solely responsible for the means, methods, techniques, sequences, and procedures of construction and safety precautions and programs incidental thereto. The CONTRACTOR shall be responsible to see that the completed WORK complies accurately with the Contract Documents.
- B. The CONTRACTOR shall designate in writing and keep on the WORK site at all times during its progress a technically qualified, English-speaking superintendent, who is an employee of the CONTRACTOR and who shall not be replaced without written notice to the OWNER and the ENGINEER. The superintendent will be the CONTRACTOR's representative at the site and shall have authority to act on behalf of the CONTRACTOR. All communications given to the superintendent shall be as binding as if given to the CONTRACTOR. The CONTRACTOR shall issue all its communications to the OWNER through the ENGINEER and the ENGINEER only.
- C. The CONTRACTOR's superintendent shall be present at the site of the WORK at all times while WORK is in progress. Failure to observe this requirement shall be considered suspension of the WORK by the CONTRACTOR until such time as such superintendent is again present at the site.

#### 6.2 LABOR, MATERIALS, AND EQUIPMENT

- A. The CONTRACTOR shall provide competent, suitably qualified personnel to survey and lay out the WORK and perform construction as required by the Contract Documents. The CONTRACTOR shall furnish, erect, maintain, and remove the construction plant and any temporary works as may be required. The CONTRACTOR shall at all times maintain good discipline and order at the site. Except in connection with the safety or protection of persons or the WORK or property at the site or adjacent thereto, and except as otherwise indicated in the Contract Documents, all WORK at the site shall be performed during regular working hours, and the CONTRACTOR will not permit overtime work or the performance of work on Saturday, Sunday, or any legal holiday without the OWNER's written consent. The CONTRACTOR shall apply for this consent through the ENGINEER.
- B. Except as otherwise provided in this Paragraph, the CONTRACTOR shall receive no additional compensation for overtime work, i.e., work in excess of 8 hours in any one calendar day or 40 hours in any one calendar week, even though such overtime work may be required under emergency conditions and may be ordered by the ENGINEER in writing. Additional compensation will be paid the CONTRACTOR for overtime work only in the



## SECTION 00700 - GENERAL CONDITIONS

event extra work is ordered by the ENGINEER and the Change Order specifically authorizes the use of overtime work and then only to such extent as overtime wages are regularly being paid by the CONTRACTOR for overtime work of a similar nature in the same locality.

- C. All costs of inspection and testing performed during overtime work by the CONTRACTOR which is allowed solely for the convenience of the CONTRACTOR shall be borne by the CONTRACTOR. The OWNER shall have the authority to deduct the cost of all such inspection and testing from any partial payments otherwise due to the CONTRACTOR.
  - D. Unless otherwise specified in the Contract Documents, the CONTRACTOR shall furnish and assume full responsibility for all materials, equipment, labor, transportation, construction equipment and machinery, tools, appliances, fuel, power, light, heat, telephone, water, sanitary facilities, and all other facilities and incidentals necessary for the furnishing, performance, testing, start-up, and completion of the WORK.
  - E. All materials and equipment to be incorporated into the WORK shall be of good quality and new, except as otherwise provided in the Contract Documents. All warranties and guarantees specifically called for by the Specifications shall expressly run to the benefit of the OWNER. If required by the ENGINEER, the CONTRACTOR shall furnish satisfactory evidence (including reports of required tests) as to the kind and quality of materials and equipment. All materials and equipment shall be applied, installed, connected, erected, used, cleaned, and conditioned in accordance with the instructions of the applicable Supplier except as otherwise provided in the Contract Documents; but no provisions of any such instructions will be effective to assign to the ENGINEER, or any of the ENGINEER consultants, agents, or employees, any duty or authority to supervise or direct the furnishing or performance of the WORK or any duty or authority to undertake responsibility contrary to the provisions of Paragraphs 9.9C and 9.9D.
  - F. The CONTRACTOR shall at all times employ sufficient labor and equipment for prosecuting the several classes of WORK to full completion in the manner and time set forth in and required by these specifications. All workers shall have sufficient skill and experience to perform properly the WORK assigned to them. Workers engaged in special WORK, or skilled WORK, shall have sufficient experience in such WORK and in the operation of the equipment required to perform all WORK, properly and satisfactorily.
  - G. Any person employed by the CONTRACTOR or by any Subcontractor who, in the opinion of the ENGINEER, does not perform the WORK in a proper and skillful manner, or is intemperate or disorderly shall, at the written request of the ENGINEER, be removed forthwith by the CONTRACTOR or Subcontractor employing such person, and shall not be employed again in any portion of the WORK without the approval of the ENGINEER. Should the CONTRACTOR fail to remove such person or persons as required above, or fail to furnish suitable and sufficient personnel for the proper prosecution of the WORK, the ENGINEER may suspend the WORK by written notice until such orders are complied with.
- 6.3 ADJUSTING PROGRESS SCHEDULE. The CONTRACTOR shall submit monthly updates of the progress schedule to the ENGINEER for acceptance in accordance with the provisions in Section 01300 - CONTRACTOR Submittals in the General Requirements.

## SECTION 00700 - GENERAL CONDITIONS

- 6.4 SUBSTITUTES OR "OR-EQUAL" ITEMS. The CONTRACTOR shall submit proposed substitutes or "or-equal" items in accordance with the provisions in Section 01300 - CONTRACTOR Submittals in the General Requirements.
- 6.5 CONCERNING SUBCONTRACTORS, SUPPLIERS, AND OTHERS.
- A. The CONTRACTOR shall be responsible to the OWNER and the ENGINEER for the acts and omissions of its Subcontractors and their employees to the same extent as CONTRACTOR is responsible for the acts and omissions of its own employees. Nothing contained in this Paragraph shall create any contractual relationship between any Subcontractor and the OWNER or the ENGINEER nor relieve the CONTRACTOR of any liability or obligation under the prime contract.
- B. The CONTRACTOR shall perform not less than 40% of the WORK with its own forces (i.e., without subcontracting). The 40% requirement shall be understood to mean that the CONTRACTOR shall perform, with its own organization, WORK amounting to at least 40% of the awarded contract amount. The 40% requirement will be calculated based upon the total of the subcontract amounts submitted for contract award, and any other information requested by the OWNER from the apparent low bidder.
- 6.6 PERMITS
- A. Unless otherwise provided in the Supplementary General Conditions, the CONTRACTOR shall obtain and pay for all construction permits and licenses from the agencies having jurisdiction, including the furnishing of insurance and bonds if required by such agencies. The enforcement of such requirements under this contract shall not be made the basis for claims for additional compensation. The OWNER shall assist the CONTRACTOR, when necessary, in obtaining such permits and licenses. The CONTRACTOR shall pay all governmental charges and inspection fees necessary for the prosecution of the WORK, which are applicable at the time of opening of Bids. The CONTRACTOR shall pay all charges of utility owners for connections to the WORK.
- B. These Contract Documents may require that the WORK be performed within the conditions and/or requirements of local, state and/or federal permits. These permits may be bound within the Contract Documents, included within the Contract Documents by reference, or included as part of the WORK, as designated in this Section. The CONTRACTOR is responsible for completing the WORK required for compliance with all permit requirements; this WORK is incidental to other items in the Contract Documents. Any reference to the PERMITTEE in the permits shall mean the CONTRACTOR. If any permits were acquired by the OWNER, this action was done to expedite the start of construction. If the CONTRACTOR does not complete the WORK within the specified permit window, the CONTRACTOR shall be responsible for the permit extension, and for completing any additional requirements placed upon the permit.
- C. The OWNER shall apply for, and obtain, the necessary building permit for this Project, however, the CONTRACTOR is responsible for scheduling and coordinating all necessary inspections. The CBJ Inspection number is 586-1703. All other provisions of this Section remain in effect.

## SECTION 00700 - GENERAL CONDITIONS

- 6.7 PATENT FEES AND ROYALTIES. The CONTRACTOR shall pay all license fees and royalties and assume all costs incident to the use in the performance of the WORK or the incorporation in the WORK of any invention, design, process, product, software or device which is the subject of patent rights or copyrights held by others. If a particular invention, design, process, product, or device is specified in the Contract Documents for use in the performance of the WORK and if to the actual knowledge of the OWNER or the ENGINEER its use is subject to patent rights or copyrights calling for the payment of any license fee or royalty to others, the existence of such rights shall be disclosed by the OWNER in the Contract Documents. The CONTRACTOR shall indemnify, defend and hold harmless the OWNER and the ENGINEER and anyone directly or indirectly employed by either of them from and against all claims, damages, losses, and expenses (including attorneys' fees and court costs) arising out of any infringement of patent rights or copyrights incident to the use in the performance of the WORK or resulting from the incorporation in the WORK of any invention, design, process, product, or device not specified in the Contract Documents, and shall defend all such claims in connection with any alleged infringement of such rights.
- 6.8 LAWS AND REGULATIONS. The CONTRACTOR shall observe and comply with all federal, state, and local laws, ordinances, codes, orders, and regulations which in any manner affect those engaged or employed on the WORK, the materials used in the WORK, or the conduct of the WORK. If any discrepancy or inconsistency should be discovered in this contract in relation to any such law, ordinance, code, order, or regulation, the CONTRACTOR shall report the same in writing to the ENGINEER. The CONTRACTOR shall indemnify, defend, and hold harmless the OWNER, the ENGINEER, and their officers, agents, and employees against all claims or liability arising from violation of any such law, ordinance, code, order, or regulation, whether by CONTRACTOR or by its employees, Subcontractors, or third parties. Any particular law or regulation specified or referred to elsewhere in the Contract Documents shall not in any way limit the obligation of the CONTRACTOR to comply with all other provisions of federal, state, and local laws and regulations. The OWNER may, per AS 36.30, audit the CONTRACTOR's or Subcontractor(s) records that are related to the cost or pricing data for this contract, all related Change Orders, and/or contract modifications.
- 6.9 TAXES. The CONTRACTOR shall pay all sales, consumer, use, and other similar taxes required to be paid by the CONTRACTOR in accordance with the Laws and Regulations of the place of the Project which are applicable during the performance of the WORK.
- 6.10 USE OF PREMISES. The CONTRACTOR shall confine construction equipment, the storage of materials and equipment, and the operations of workers to (1) the Project site, (2) the land and areas identified in and permitted by the Contract Documents, and (3) the other land and areas permitted by Laws and Regulations, rights-of-way, permits, leases and easements. The CONTRACTOR shall assume full responsibility for any damage to any such land or area, or to the owner or occupant thereof or of any land or areas contiguous thereto, resulting from the performance of the WORK. Should any claim be made against the OWNER or the ENGINEER by any such owner or occupant because of the performance of the WORK, the CONTRACTOR shall promptly attempt to settle with such other party by agreement or otherwise resolve the claim through litigation. The CONTRACTOR shall, to the fullest extent permitted by Laws and Regulations, indemnify, defend, and hold the OWNER and the ENGINEER harmless from and against all claims, damages, losses, and expenses (including, but not limited to, fees of engineers attorneys, and other professionals and court costs) arising directly, indirectly, or consequentially out of any action, legal or equitable, brought by any such owner or occupant against the OWNER, the ENGINEER, their Consultants, Sub-consultants, and the officers,

## SECTION 00700 - GENERAL CONDITIONS

directors, employees and agents of each and any of them to the extent caused by or based upon the CONTRACTOR's performance of the WORK.

### 6.11 SAFETY AND PROTECTION

- A. The CONTRACTOR shall be responsible for initiating, maintaining, and supervising all safety precautions and programs in connection with the WORK. The CONTRACTOR shall take all necessary precautions for the safety of, and shall provide the necessary protection to prevent damage, injury or loss to:
1. all employees on the WORK and other persons and organizations who may be affected thereby;
  2. all the WORK and materials and equipment to be incorporated therein, whether in storage on or off the site; and
  3. other property at the site or adjacent thereto, including trees, shrubs, lawns, walks, pavements, roadways, structures, and utilities not designated for removal, relocation, or replacement in the course of construction.
- B. The CONTRACTOR shall comply with all applicable Laws and Regulations whether referred to herein or not) of any public body having jurisdiction for the safety of persons or property or to protect them from damage, injury, or loss and shall erect and maintain all necessary safeguards for such safety and protection. The CONTRACTOR shall notify owners of adjacent property and utilities when prosecution of the WORK may affect them, and shall cooperate with them in the protection, removal, relocation, and replacement of their property.
- C. The CONTRACTOR shall designate a qualified and experienced safety representative at the site whose duties and responsibilities shall be the prevention of accidents and the maintaining and supervising of safety precautions and program.
- D. Materials that contain hazardous substances or mixtures may be required on the WORK. A Material Safety Data Sheet shall be requested by the CONTRACTOR from the manufacturer of any hazardous product used.
- E. Material usage shall be accomplished with strict adherence to all safety requirements and all manufacturer's warnings and application instructions listed on the Material Safety Data Sheet and on the product container label.
- F. The CONTRACTOR shall be responsible for coordinating communications on any exchange of Material Safety Data Sheets or other hazardous material information that is required to be made available to, or exchanged between, or among, employers at the site in accordance with Laws or Regulations.
- G. The CONTRACTOR shall notify the ENGINEER if it considers a specified product or its intended usage to be unsafe. This notification must be given to the ENGINEER prior to the product being ordered, or if provided by some other party, prior to the product being incorporated in the WORK.

## SECTION 00700 - GENERAL CONDITIONS

### 6.12 SHOP DRAWINGS AND SAMPLES

- A. After checking and verifying all field measurements and after complying with applicable procedures specified in the General Requirements, the CONTRACTOR shall submit to the ENGINEER for review, all Shop Drawings in accordance with Section 01300 - CONTRACTOR Submittals in the General Requirements.
- B. The CONTRACTOR shall also submit to the ENGINEER for review all samples in accordance with Section 01300 - CONTRACTOR Submittals in the General Requirements.
- C. Before submittal of each shop drawing or sample, the CONTRACTOR shall have determined and verified all quantities, dimensions, specified performance criteria, installation requirements, materials, catalog numbers, and similar data with respect thereto and reviewed or coordinated each Shop Drawing or sample with other Shop Drawings and samples and with the requirements of the WORK and the Contract Documents.

6.13 CONTINUING THE WORK. The CONTRACTOR shall carry on the WORK and adhere to the progress schedule during all disputes or disagreements with the OWNER. No work shall be delayed or postponed pending resolution of any disputes or disagreements, except as the CONTRACTOR and the OWNER may otherwise agree in writing.

### 6.14 INDEMNIFICATION

- A. To the fullest extent permitted by Laws and Regulations, the CONTRACTOR shall indemnify, defend, and hold harmless the OWNER, the ENGINEER, their Consultants, Sub-consultants and the officers, directors, employees, and agents of each and any of them, against and from all claims and liability arising under, by reason of or incidentally to the contract or any performance of the WORK, but not from the sole negligence or willful misconduct of the OWNER, and the ENGINEER. Such indemnification by the CONTRACTOR shall include but not be limited to the following:
  - 1. Liability or claims resulting directly or indirectly from the negligence or carelessness of the CONTRACTOR, its employees, or agents in the performance of the WORK, or in guarding or maintaining the same, or from any improper materials, implements, or appliances used in its construction, or by or on account of any act or omission of the CONTRACTOR, its employees, agents, or third parties;
  - 2. Liability or claims arising directly or indirectly from bodily injury, occupational sickness or disease, or death of the CONTRACTOR's or Subcontractor's own employees engaged in the WORK resulting in actions brought by or on behalf of such employees against the OWNER, and the ENGINEER;
  - 3. Liability or claims arising directly or indirectly from or based on the violation of any law, ordinance, regulation, order, or decree, whether by the CONTRACTOR, its employees, or agents;
  - 4. Liability or claims arising directly or indirectly from the use or manufacture by the CONTRACTOR, its employees, or agents in the performance of this contract of any copyrighted or non-copyrighted composition, secret process, patented or non-patented invention, computer software, article, or appliance, unless otherwise specifically stipulated in this contract.

## SECTION 00700 - GENERAL CONDITIONS

5. Liability or claims arising directly or indirectly from the breach of any warranties, whether express or implied, made to the OWNER or any other parties by the CONTRACTOR, its employees, or agents;
  6. Liabilities or claims arising directly or indirectly from the willful or criminal misconduct of the CONTRACTOR, its employees, or agents; and,
  7. Liabilities or claims arising directly or indirectly from any breach of the obligations assumed herein by the CONTRACTOR.
- B. The CONTRACTOR shall reimburse the ENGINEER and the OWNER for all costs and expenses, (including but not limited to fees and charges of engineers, attorneys, and other professionals and court costs including all costs of appeals) incurred by said OWNER, and the ENGINEER in enforcing the provisions of this Paragraph 6.14.
- C. The indemnification obligation under this Paragraph 6.14 shall not be limited in any way by any limitation of the amount or type of damages, compensation, or benefits payable by or for the CONTRACTOR or any such Subcontractor or other person or organization under workers' compensation acts, disability benefit acts, or other employee benefit acts.
- 6.15 CONTRACTOR'S DAILY REPORTS. The CONTRACTOR shall complete a daily report indicating total manpower for each construction trade, major equipment on site, each Subcontractor's manpower, weather conditions, etc., involved in the performance of the WORK. The daily report shall be completed on forms provided by the ENGINEER and shall be submitted to the ENGINEER at the conclusion of each workday. The report should comment on the daily progress and status of the WORK within each major component of the WORK. These components will be decided by the ENGINEER. CONTRACTOR shall record the name, affiliation, time of arrival and departure, and reason for visit for all visitors to the location of the WORK.
- 6.16 ASSIGNMENT OF CONTRACT. The CONTRACTOR shall not assign, sublet, sell, transfer, or otherwise dispose of the contract or any portion thereof, or its right, title, or interest therein, or obligations thereunder, without the written consent of the OWNER except as imposed by law. If the CONTRACTOR violates this provision, the contract may be terminated at the option of the OWNER. In such event, the OWNER shall be relieved of all liability and obligations to the CONTRACTOR and to its assignee or transferee, growing out of such termination.
- 6.17 CONTRACTOR'S RESPONSIBILITY FOR UTILITY PROPERTY AND SERVICES. It is understood that any turn-on or turn-off, line locates and any other work or assistance necessary by the CBJ Water Utilities Division, will be at the CONTRACTOR's expense unless otherwise stated in the bid documents. All cost must be agreed to prior to any related actions, and will be considered incidental to the project cost. Billing to the CONTRACTOR will be direct from the CBJ Water Utilities Division.
- 6.18 OPERATING WATER SYSTEM VALVES
- A. The CONTRACTOR shall submit a written request, to the ENGINEER, for approval to operate any valve on any in-service section of the CBJ water system. The request must be submitted at least 24-hours prior to operating any valves. The CBJ Water Utilities Division reserves the right to approve or deny the request. The request shall specifically identify each valve to be operated, the time of operation, and the operation to be performed. The

## SECTION 00700 - GENERAL CONDITIONS

CONTRACTOR shall obtain the written approval of the ENGINEER for any scheduled operation before operating any valve.

- B. The CONTRACTOR shall be responsible for all damages, both direct and consequential, to the City or any other party, caused by unauthorized operation of any valve of the CBJ water system.

6.19 CONTRACTOR'S WORK SCHEDULE LIMITATIONS. Construction of Buildings and Projects. It is unlawful to operate any pile driver, power shovel, pneumatic hammer, derrick, power hoist, or similar heavy construction equipment before 7:00 a.m. or after 10:00 p.m., Monday through Friday, or before 9:00 a.m. or after 10:00 p.m., Saturday and Sunday, unless a permit shall first be obtained from the City and Borough Building Official. Such permit shall be issued by the Building Official only upon a determination that such operation during hours not otherwise permitted hereunder is necessary and will not result in unreasonable disturbance to surrounding residents.

### ARTICLE 7 OTHER WORK

#### 7.1 RELATED WORK AT SITE

- A. The OWNER may perform other work related to the Project at the site by the OWNER's own forces, have other work performed by utility owners, or let other direct contracts therefor which may contain General Conditions similar to these. If the fact that such other work is to be performed was not noted in the Contract Documents, written notice thereof will be given to the CONTRACTOR prior to starting any such other work.
- B. The CONTRACTOR shall afford each other contractor who is a party to such a direct contract and each utility owner (or the OWNER, if the OWNER is performing the additional work with the OWNER's employees) proper and safe access to the site and a reasonable opportunity for the introduction and storage of materials and equipment and the execution of such work, and shall properly connect and coordinate the WORK with theirs. The CONTRACTOR shall do all cutting, fitting, and patching of the WORK that may be required to make its several parts come together properly and integrate with such other work. The CONTRACTOR shall not endanger any work of others by cutting, excavating, or otherwise altering their work and will only cut or alter their work with the written consent of the ENGINEER and the others whose work will be affected.
- C. If the proper execution or results of any part of the CONTRACTOR's work depends upon the work of any such other contractor or utility owner (or OWNER), the CONTRACTOR shall inspect and report to the ENGINEER in writing any delays, defects, or deficiencies in such other work that render it unavailable or unsuitable for such proper execution and results. The CONTRACTOR's failure to report such delays, defects, or deficiencies will constitute an acceptance of the other work as fit and proper for integration with the CONTRACTOR's work except for latent or nonapparent defects and deficiencies in the other work.

7.2 COORDINATION. If the OWNER contracts with others for the performance of other work on the Project at the site, the person or organization who will have authority and responsibility for coordination of the activities among the various prime contractors will be identified in the Supplementary General Conditions, and the specific matters to be covered by such authority and

## SECTION 00700 - GENERAL CONDITIONS

responsibility will be itemized and the extent of such authority and responsibilities will be provided in the Supplementary General Conditions.

### ARTICLE 8 OWNER'S RESPONSIBILITIES

#### 8.1 COMMUNICATIONS

- A. The OWNER shall issue all its communications to the CONTRACTOR through the ENGINEER.
- B. The CONTRACTOR shall issue all its communications to the OWNER through the ENGINEER.

8.2 PAYMENTS. The OWNER shall make payments to the CONTRACTOR as provided in Paragraphs 14.5, 14.8, 14.9 and 14.10.

8.3 LANDS, EASEMENTS, AND SURVEYS. The OWNER's duties in respect of providing lands and easements and providing surveys to establish reference points are set forth in Paragraphs 4.1 and 4.5.

8.4 CHANGE ORDERS. The OWNER shall execute Change Orders as indicated in Paragraph 10.1F.

8.5 INSPECTIONS AND TESTS. The OWNER's responsibility in respect of inspections, tests, and approvals is set forth in Paragraph 13.3.

8.6 SUSPENSION OF WORK. In connection with the OWNER's right to stop WORK or suspend WORK, see Paragraphs 13.4 and 15.1.

8.7 TERMINATION OF AGREEMENT. Paragraphs 15.2 and 15.3 deal with the OWNER's right to terminate services of the CONTRACTOR.

### ARTICLE 9 ENGINEER'S STATUS DURING CONSTRUCTION

9.1 OWNER'S REPRESENTATIVE. The ENGINEER will be the OWNER's representative during the construction period. The duties and responsibilities and the limitations of authority of the ENGINEER as the OWNER's representative during construction are set forth in the Contract Documents.

9.2 VISITS TO SITE. The ENGINEER will make visits to the site during construction to observe the progress and quality of the WORK and to determine, in general, if the WORK is proceeding in accordance with the Contract Documents. Exhaustive or continuous on-site inspections to check the quality or quantity of the WORK will not be required of the ENGINEER. The ENGINEER will not, during such visits, or as a result of such observations of the CONTRACTOR's WORK in progress, supervise, direct, or have control over the CONTRACTOR's WORK.

9.3 PROJECT REPRESENTATION. The ENGINEER may furnish an Inspector to assist in observing the performance of the WORK. The duties, responsibilities, and limitations of authority are as follows:

- A. Duties, Responsibilities and Limitations of Authority of Inspector



## SECTION 00700 - GENERAL CONDITIONS

General. The Inspector, who is the ENGINEER's Agent, will act as directed by and under the supervision of the ENGINEER and will confer with the ENGINEER regarding its actions. The Inspector's dealings in matters pertaining to the on-site WORK shall, in general, be only with the ENGINEER and the CONTRACTOR, and dealings with Subcontractors shall only be through or with the full knowledge of the CONTRACTOR. Written communication with the OWNER will be only through or as directed by the ENGINEER.

Duties and Responsibilities. The Inspector may:

1. Review the progress schedule, list of Shop Drawing submittals and schedule of values prepared by the CONTRACTOR and consult with the ENGINEER concerning their acceptability.
2. Attend pre-construction conferences. Arrange a schedule of progress meetings and other job conferences as required in consultation with the ENGINEER and notify those expected to attend in advance. Attend meetings and maintain and circulate copies of minutes thereof.
3. Serve as the ENGINEER's liaison with the CONTRACTOR, working principally through the CONTRACTOR's superintendent and assist said superintendent in understanding the intent of the Contract Documents. Assist the ENGINEER in serving as the OWNER's liaison with the CONTRACTOR when the CONTRACTOR's operations affect the OWNER's on-site operations.
4. As requested by the ENGINEER, assist in obtaining from the OWNER additional details or information, when required at the site for proper execution of the WORK.
5. Receive and record date of receipt of Shop Drawings and samples, receive samples which are furnished at the site by the CONTRACTOR and notify the ENGINEER of their availability for examination.
6. Conduct on-site observations of the WORK in progress to assist the ENGINEER in determining if the WORK is proceeding in accordance with the Contract Documents.
7. Report to the ENGINEER whenever the Inspector believes that any WORK is unsatisfactory, faulty, or defective or does not conform to the Contract Documents, or does not meet the requirements of any inspection, tests or approval required to be made or has been damaged prior to final payment; and advise the ENGINEER when the Inspector believes WORK should be corrected or rejected or should be uncovered for observation, or requires special testing, inspection, or approval.
8. Verify that the tests, equipment, and systems startups and operating and maintenance instruction are conducted as required by the Contract Documents and in presence of the required personnel, and that the CONTRACTOR maintains adequate records thereof; observe, record and report to the ENGINEER appropriate details relative to the test procedures and start-ups.
9. Accompany visiting inspectors representing public or other agencies having jurisdiction over the WORK, record the outcome of these inspections, and report to the ENGINEER.
10. Transmit to the CONTRACTOR the ENGINEER's clarifications and interpretations of the Contract Documents.
11. Consider and evaluate the CONTRACTOR's suggestions for modifications in the Contract Documents and report them with recommendations to the ENGINEER.
12. Maintain at the job site orderly files for correspondence, reports of job conferences, Shop Drawings and sample submittals, reproductions of original Contract Documents including all addenda, Change Orders, field orders, additional Drawings issued

## SECTION 00700 - GENERAL CONDITIONS

subsequent to the execution of the contract, the ENGINEER's clarifications and interpretations of the Contract Documents, progress reports, and other related documents.

13. Keep a diary or log book, recording hours on the job site, weather conditions, data relative to questions of extras or deductions, list all project visitors, daily activities, decisions, observations in general, and specific observations in more detail as in the case of performing and observing test procedures. Send copies to the ENGINEER.
14. Record names, addresses, and telephone numbers of the CONTRACTOR, Subcontractors, and major suppliers of materials and equipment.
15. Furnish the ENGINEER with periodic reports as required of progress of the WORK and the CONTRACTOR's compliance with the accepted progress schedule and schedule of CONTRACTOR submittals.
16. Consult with the ENGINEER in advance of scheduled major tests, inspections, or start of important phases of the WORK.
17. Report immediately to the ENGINEER upon the occurrence of any accident.
18. Review applications for payment with the CONTRACTOR for compliance with the established procedure for their submittal and forward them with recommendations to the ENGINEER, noting particularly their relation to the schedule of values, WORK completed, and materials and equipment delivered at the site but not incorporated in the WORK.
19. During the course of the WORK, verify that certificates, maintenance and operation manuals, and other data required to be assembled and furnished by the CONTRACTOR are applicable to the items actually installed; and deliver this material to the ENGINEER for its review and forwarding to the OWNER prior to final acceptance of the WORK.
20. Before the ENGINEER prepares a Certificate of Substantial Completion/Notice of Completion, as applicable, review the CONTRACTOR's punch list items requiring completion or correction and add any items that CONTRACTOR has omitted.
21. Conduct final inspection in the company of the ENGINEER, the OWNER, and the CONTRACTOR, and prepare a final punch list of items to be completed or corrected.
22. Verify that all items on the punch list have been completed or corrected and make recommendations to the ENGINEER concerning acceptance.

Limitations of Authority. Except upon written instruction of the ENGINEER, the Inspector:

1. Shall not authorize any deviation from the Contract Documents or approve any substitute material or equipment.
2. Shall not exceed limitations on the ENGINEER's authority as set forth in the Contract Documents.
3. Shall not undertake any of the responsibilities of the CONTRACTOR, Subcontractors or CONTRACTOR's superintendent, or expedite the WORK.
4. Shall not advise on or issue directions relative to any aspect of the means, methods, techniques, sequences, or procedures of construction unless such is specifically called for in the Contract Documents.
5. Shall not advise on or issue directions as to safety precautions and programs in connection with the WORK.

9.4 CLARIFICATIONS AND INTERPRETATIONS. The ENGINEER will issue with reasonable promptness such written clarifications or interpretations of the requirements of the Contract

## SECTION 00700 - GENERAL CONDITIONS

Documents (in the form of Drawings or otherwise) as the ENGINEER may determine necessary, which shall be consistent with, or reasonably inferred from, the overall intent of the Contract Documents.

- 9.5 AUTHORIZED VARIATIONS IN WORK. The ENGINEER may authorize variations in the WORK from the requirements of the Contract Documents. These may be accomplished by a Field Order and will require the CONTRACTOR to perform the WORK involved in a manner that minimizes the impact to the WORK and the contract completion date. If the CONTRACTOR believes that a Field Order justifies an increase in the Contract Price or an extension of the Contract Time, the CONTRACTOR may make a claim therefor as provided in Article 11 or 12.
- 9.6 REJECTING DEFECTIVE WORK. The ENGINEER will have authority to reject WORK which the ENGINEER believes to be defective and will also have authority to require special inspection or testing of the WORK as provided in Paragraph 13.3G, whether or not the WORK is fabricated, installed, or completed.
- 9.7 CONTRACTOR SUBMITTALS, CHANGE ORDERS, AND PAYMENTS
- A. In accordance with the procedures set forth in the General Requirements, the ENGINEER will review all CONTRACTOR submittals, including Shop Drawings, samples, substitutes, or "or equal" items, etc., in order to determine if the items covered by the submittals will, after installation or incorporation in the WORK, conform to the requirements of the Contract Documents and be compatible with the design concept of the completed project as a functioning whole as indicated by the Contract Documents. The ENGINEER's review will not extend to means, methods, techniques, sequences or procedures of construction or to safety precautions or programs incident thereto.
  - B. In connection with the ENGINEER's responsibilities as to Change Orders, see Articles 10, 11, and 12.
  - C. In connection with the ENGINEER's responsibilities in respect of Applications for Payment, see Article 14.
- 9.8 DECISIONS ON DISPUTES
- A. The ENGINEER will be the initial interpreter of the requirements of the Contract Documents and judge of the acceptability of the WORK thereunder. Claims, disputes, and other matters relating to the acceptability of the WORK; the interpretation of the requirements of the Contract Documents pertaining to the performance of the WORK; and those claims under Articles 11 and 12 in respect to changes in the Contract Price or Contract Time will be referred initially to the ENGINEER in writing with a request for formal decision in accordance with this paragraph, which the ENGINEER will render in writing within 30 days of receipt of the request. Written notice of each such claim, dispute, and other matter will be delivered by the CONTRACTOR to the ENGINEER promptly (but in no event later than 30 days) after the occurrence of the event giving rise thereto. Written supporting data will be submitted to the ENGINEER within 60 days after such occurrence unless the ENGINEER allows an additional period of time to ascertain more accurate data in support of the claim.

## SECTION 00700 - GENERAL CONDITIONS

- B. The rendering of a decision by the ENGINEER with respect to any such claim, dispute, or other matter (except any which have been waived by the making or acceptance of final payment as provided in Paragraph 14.12) will be a condition precedent to any exercise by the OWNER or the CONTRACTOR of such rights or remedies as either may otherwise have under the Contract Documents or by Law or Regulations in respect of any such claim, dispute, or other matter.

### 9.9 LIMITATION ON ENGINEER'S RESPONSIBILITIES

- A. Neither the ENGINEER's authority to act under this Article or other provisions of the Contract Documents nor any decision made by the ENGINEER in good faith either to exercise or not exercise such authority shall give rise to any duty or responsibility of the ENGINEER to the CONTRACTOR, any Subcontractor, any Supplier, any surety for any of them, or any other person or organization performing any of the WORK.
- B. Whenever in the Contract Documents the terms "as ordered," "as directed," "as required," "as allowed," "as reviewed," "as approved," or terms of like effect or import are used, or the adjectives "reasonable," "suitable," "acceptable," "proper," or "satisfactory" or adjectives of like effect or import are used to describe a requirement, direction, review, or judgment of the ENGINEER as to the WORK, it is intended that such requirement, direction, review, or judgment will be solely to evaluate the WORK for compliance with the requirements of the Contract Documents, and conformance with the design concept of the completed Project as a functioning whole as indicated by the Contract Documents, unless there is a specific statement indicating otherwise. The use of any such term or adjective shall not be effective to assign to the ENGINEER any duty or authority to supervise or direct the performance of the WORK or any duty or authority to undertake responsibility contrary to the provisions of Paragraph 9.9C or 9.9D.
- C. The ENGINEER will not supervise, direct, control, or have authority over or be responsible for the CONTRACTOR's means, methods, techniques, sequences, or procedures of construction, or the safety precautions and programs incident thereto, or for any failure of the CONTRACTOR to comply with Laws and Regulations, applicable to the performance of the WORK. The ENGINEER will not be responsible for the CONTRACTOR's failure to perform the WORK in accordance with the Contract Documents.
- D. The ENGINEER will not be responsible for the acts or omissions of the CONTRACTOR nor of any Subcontractor, supplier, or any other person or organization performing any of the WORK.

## SECTION 00700 - GENERAL CONDITIONS

### ARTICLE 10 CHANGES IN THE WORK

#### 10.1 GENERAL

- A. Without invalidating the Agreement and without notice to any surety, the OWNER may at any time or from time to time, order additions, deletions, or revisions in the WORK; these will be authorized by a written Field Order and/or a Change Order issued by the ENGINEER.
- B. If the CONTRACTOR believes that it is entitled to an increase or decrease in the Contract Price, or an extension or shortening in the Contract Time as the result of a Field Order, a claim may be made as provided in Articles 11 and 12.
- C. If the OWNER and CONTRACTOR agree on the value of any work, or the amount of Contract Time that should be allowed as a result of a Field Order, upon receiving written notice from the ENGINEER, the CONTRACTOR shall proceed so as to minimize the impact on and delays to the work pending the issuance of a Change Order.
- D. If the OWNER and the CONTRACTOR are unable to agree as to the extent, if any, of an increase or decrease in the Contract Price or an extension or shortening of the Contract Time that should be allowed as a result of a Field Order, the ENGINEER can direct the CONTRACTOR to proceed on the basis of Time and Materials so as to minimize the impact on and delays to WORK, and a claim may be made therefor as provided in Articles 11 and 12.
- E. The CONTRACTOR shall not be entitled to an increase in the Contract Price nor an extension of the Contract Time with respect to any work performed that is not required by the Contract Documents as amended, modified, supplemented by Change Order, except in the case of an emergency and except in the case of uncovering work as provided in Paragraph 13.3G.
- F. The OWNER and the CONTRACTOR shall execute appropriate Change Orders covering:
  - 1. changes in the WORK which are ordered by the OWNER pursuant to Paragraph 10.1A;
  - 2. changes required because of acceptance of Defective WORK under Paragraph 13.7;
  - 3. changes in the Contract Price or Contract Time which are agreed to by the parties; or
  - 4. changes in the Contract Price or Contract Times which embody the substance of any written decision rendered by the ENGINEER pursuant to Paragraph 9.8.
- G. If notice of any change is required by the provisions of any Bond to be given to a surety, the giving of any such notice will be the CONTRACTOR's responsibility, and the amount of each applicable Bond shall be adjusted accordingly.

#### 10.2 ALLOWABLE QUANTITY VARIATIONS

- A. In the event of an increase or decrease in Bid item quantity of a unit price contract, the total amount of WORK actually done or materials or equipment furnished shall be paid for according to the unit price established for such WORK under the Contract Documents, wherever such unit price has been established; provided, that an adjustment in the Contract Price may be made for changes which result in an increase or decrease in excess of 25% of

## SECTION 00700 - GENERAL CONDITIONS

the estimated quantity of any major item of the WORK. Major Item is defined as any bid item amount that is ten percent (10%) or more of the total contract amount.

- B. In the event a part of the WORK is to be entirely eliminated and no lump sum or unit price is named in the Contract Documents to cover such eliminated work, the price of the eliminated work shall be agreed upon in writing by the OWNER and the CONTRACTOR. If the OWNER and the CONTRACTOR fail to agree upon the price of the eliminated work, said price shall be determined in accordance with the provisions of Article 11.

### ARTICLE 11 CHANGE OF CONTRACT PRICE

#### 11.1 GENERAL

- A. The Contract Price constitutes the total compensation payable to the CONTRACTOR for performing the WORK. All duties, responsibilities, and obligations assigned to or undertaken by the CONTRACTOR to complete the WORK shall be at its expense without change in the Contract Price.
- B. The Contract Price may only be changed by a Change Order. Any claim for an increase in the Contract Price shall be based on written notice delivered by the CONTRACTOR to the ENGINEER promptly (but in no event later than 7 days) after the start of the occurrence or the event giving rise to the claim and stating the general nature of the claim. Notice of the amount of the claim with supporting data shall be delivered within 14 days after such occurrence (unless the ENGINEER allows an additional period of time to ascertain more accurate data in support of the claim) and shall be accompanied by the CONTRACTOR's written statement that the amount claimed covers all known amounts (direct, indirect, and consequential) to which the CONTRACTOR is entitled as a result of said occurrence or event. All claims for adjustment in the Contract Price shall be determined by the ENGINEER in accordance with Paragraph 9.8A if the OWNER and the CONTRACTOR cannot otherwise agree on the amount involved. No claim for an adjustment in the Contract Price will be valid if not submitted in accordance with this Paragraph 11.1B.
- C. The value of any WORK covered by a Change Order or of any claim for an increase or decrease in the Contract Price shall be determined in one of the following ways:
  - 1. Where the WORK involved is covered by unit prices contained in the Contract Documents, by application of unit prices to the quantities of the items involved.
  - 2. By mutual acceptance of a lump sum, which may include an allowance for overhead and profit not necessarily in accordance with Paragraph 11.4.
  - 3. On the basis of the cost of WORK (determined as provided in Paragraphs 11.3) plus a CONTRACTOR's fee for overhead and profit (determined as provided in Paragraph 11.4).

- 11.2 COSTS RELATING TO WEATHER. The CONTRACTOR shall have no claims against the OWNER for damages for any injury to WORK, materials, or equipment, resulting from the action of the elements. If, however, in the opinion of the ENGINEER, the CONTRACTOR has made all reasonable efforts to protect the materials, equipment and work, the CONTRACTOR may be granted a reasonable extension of Contract Time to make proper repairs, renewals, and replacements of the work, materials, or equipment.

## SECTION 00700 - GENERAL CONDITIONS

### 11.3 COST OF WORK (BASED ON TIME AND MATERIALS)

- A. General. The term "cost of work" means the sum of all costs necessarily incurred and paid by the CONTRACTOR for labor, materials, and equipment in the proper performance of extra work. Except as otherwise may be agreed to in writing by the OWNER, such costs shall be in amounts no higher than those prevailing in the locality of the Project; shall include only the following items, and shall not include any of the costs itemized in Paragraph 11.5 EXCLUDED COSTS.
- B. Labor. The costs of labor will be the actual cost for wages prevailing for each craft or type of workers performing the extra work at the time the extra work is done, plus employer payments of payroll taxes, worker's compensation insurance, liability insurance, health and welfare, pension, vacation, apprenticeship funds, and other direct costs resulting from Federal, State or local laws, as well as assessments or benefits required by lawful collective bargaining agreements. Labor costs for equipment operators and helpers shall be paid only when such costs are not included in the invoice for equipment rental. The labor costs for forepersons shall be proportioned to all of their assigned work and only that applicable to extra work shall be paid. Non-direct labor costs including superintendence shall be considered part of the mark-up set out in paragraph 11.4.
- C. Materials. The cost of materials reported shall be at invoice or lowest current price at which materials are locally available and delivered to the job in the quantities involved, plus the cost of freight, delivery and storage, subject to the following:
1. Trade discounts available to the purchaser shall be credited to the OWNER notwithstanding the fact that such discounts may not have been taken by the CONTRACTOR.
  2. For materials secured by other than a direct purchase and direct billing to the purchaser, the cost shall be deemed to be the price paid to the actual supplier as determined by the ENGINEER. Mark-up except for actual costs incurred in the handling of such materials will not be allowed.
  3. Payment for materials from sources owned wholly or in part by the purchaser shall not exceed the price paid by the purchaser for similar materials from said sources on extra work items or the current wholesale price for such materials delivered to the work site, whichever price is lower.
  4. If in the opinion of the ENGINEER the cost of material is excessive, or the CONTRACTOR does not furnish satisfactory evidence of the cost of such material, then the cost shall be deemed to be the lowest current wholesale price for the quantity concerned delivered to the work site less trade discount. The OWNER reserves the right to furnish materials for the extra work and no claim shall be allowed by the CONTRACTOR for costs and profit on such materials.
- D. Equipment. The CONTRACTOR will be paid for the use of equipment at the rental rate listed for such equipment specified in the Supplementary General Conditions. Such rental rate will be used to compute payments for equipment whether the equipment is under the CONTRACTOR's control through direct ownership, leasing, renting, or another method of acquisition. The rental rate to be applied for use of each item of equipment shall be the rate resulting in the least total cost to the OWNER for the total period of use. If it is deemed

## SECTION 00700 - GENERAL CONDITIONS

necessary by the CONTRACTOR to use equipment not listed in the publication specified in the Supplementary General Conditions, an equitable rental rate for the equipment will be established by the ENGINEER. The CONTRACTOR may furnish cost data which might assist the ENGINEER in the establishment of the rental rate.

1. All equipment shall, in the opinion of the ENGINEER, be in good working condition and suitable for the purpose for which the equipment is to be used.
  2. Before construction equipment is used on the extra work, the CONTRACTOR shall plainly stencil or stamp an identifying number thereon at a conspicuous location, and shall furnish to the ENGINEER, in duplicate, a description of the equipment and its identifying number.
  3. Unless otherwise specified, manufacturer's ratings and manufacturer approved modifications shall be used to classify equipment for the determination of applicable rental rates. Equipment which has no direct power unit shall be powered by a unit of at least the minimum rating recommended by the manufacturer.
  4. Individual pieces of equipment or tools having a replacement value of \$200 or less, whether or not consumed by use, shall be considered to be small tools and no payment will be made therefor.
  5. Rental time will not be allowed while equipment is inoperative due to breakdowns.
  6. Equipment Rental Rates. Unless otherwise agreed in writing, the CONTRACTOR will be paid for the use of equipment at the rental rate listed for such equipment specified in the current edition of the following reference publication: "Rental Rate Blue Book" as published by Dataquest (a company of the Dunn and Bradstreet Corporation), 1290 Ridder Park Drive, San Jose, CA 95131, telephone number (800) 227-8444.
- E. Equipment on the Work Site. The rental time to be paid for equipment on the work site shall be the time the equipment is in productive operation on the extra work being performed and, in addition, shall include the time required to move the equipment to the location of the extra work and return it to the original location or to another location requiring no more time than that required to return it to its original location; except, that moving time will not be paid if the equipment is used on other than the extra work, even though located at the site of the extra work. Loading and transporting costs will be allowed, in lieu of moving time, when the equipment is moved by means other than its own power, except that no payment will be made for loading and transporting costs when the equipment is used at the site of the extra work on other than the extra work. The following shall be used in computing the rental time of equipment on the work site.
1. When hourly rates are listed, any part of an hour less than 30 minutes of operation shall be considered to be 1/2-hour of operation, and any part of an hour in excess of 30 minutes will be considered one hour of operation.
  2. When daily rates are listed, any part of a day less than 4 hours operation shall be considered to be 1/2-day of operation. When owner-operated equipment is used to perform extra work to be paid for on a time and materials basis, the CONTRACTOR will be paid for the equipment and operator, as set forth in Paragraphs (3), (4), and (5), following.
  3. Payment for the equipment will be made in accordance with the provisions in Paragraph 11.3D, herein.
  4. Payment for the cost of labor and subsistence or travel allowance will be made at the rates paid by the CONTRACTOR to other workers operating similar equipment already



## SECTION 00700 - GENERAL CONDITIONS

on the work site, or in the absence of such labor, established by collective bargaining agreements for the type of worker and location of the extra work, whether or not the operator is actually covered by such an agreement. A labor surcharge will be added to the cost of labor described herein in accordance with the provisions of Paragraph 11.3B, herein, which surcharge shall constitute full compensation for payments imposed by state and federal laws and all other payments made to or on behalf of workers other than actual wages.

5. To the direct cost of equipment rental and labor, computed as provided herein, will be added the allowances for equipment rental and labor as provided in Paragraph 11.4, herein.
- F. Specialty Work. Specialty work is defined as that work characterized by extraordinary complexity, sophistication, or innovation or a combination of the foregoing attributes which are unique to the construction industry. The following shall apply in making estimates for payment for specialty work:
1. Any bid item of WORK to be classified as Specialty Work shall be listed as such in the Supplementary General Conditions. Specialty work shall be performed by an entity especially skilled in the work to be performed. After validation of invoices and determination of market values by the ENGINEER, invoices for specialty work based upon the current fair market value thereof may be accepted without complete itemization of labor, material, and equipment rental costs.
  2. When the CONTRACTOR is required to perform work necessitating special fabrication or machining process in a fabrication or a machine shop facility away from the job site, the charges for that portion of the work performed at the off-site facility may, by agreement, be accepted as specialty work and accordingly, the invoices for the work may be accepted without detailed itemization.
  3. All invoices for specialty work will be adjusted by deducting all trade discounts offered or available, whether the discounts were taken or not. In lieu of the allowances for overhead and profit specified in Paragraph 11.4, herein, an allowance of 5 percent will be added to invoices for specialty work.
- G. Sureties. All work performed hereunder shall be subject to all of the provisions of the Contract Documents and the CONTRACTOR's sureties shall be bound with reference thereto as under the original Agreement. Copies of all amendments to surety bonds or supplemental surety bonds shall be submitted to the OWNER for review prior to the performance of any work hereunder.

### 11.4 CONTRACTOR'S FEE

- A. Extra work ordered on the basis of time and materials will be paid for at the actual necessary cost as determined by the ENGINEER, plus allowances for overhead and profit. The allowance for overhead and profit shall include full compensation for superintendence, bond and insurance premiums, taxes, field office expense, extended overhead, home office overhead, and all other items of expense or cost not included in the cost of labor, materials, or equipment provided for under Paragraph 11.3. The allowance for overhead and profit will be made in accordance with the following schedule:

**SECTION 00700 - GENERAL CONDITIONS**

Actual Overhead and Profit Allowance

Labor.....	15 percent
Materials.....	10 percent
Equipment.....	10 percent

To the sum of the costs and mark-ups provided for in this Article, one percent shall be added as compensation for bonding.

- B. It is understood that labor, materials, and equipment may be furnished by the CONTRACTOR or by the Subcontractor on behalf of the CONTRACTOR. When all or any part of the extra work is performed by a Subcontractor, the allowance specified herein shall be applied to the labor, materials, and equipment costs of the Subcontractor, to which the CONTRACTOR may add 5 percent of the Subcontractor's total cost for the extra work. Regardless of the number of hierarchical tiers of Subcontractors, the 5 percent increase above the Subcontractor's total cost which includes the allowances for overhead and profit specified herein may be applied one time only.

11.5 EXCLUDED COSTS. The term "Cost of the Work" shall not include any of the following:

- A. Payroll costs and other compensation of CONTRACTOR's officers, executives, principals (of partnership and sole proprietorships), general managers, engineers, estimators, attorneys' auditors, accountants, purchasing and contracting agents, expenditures, timekeepers, clerks and other personnel employed by CONTRACTOR whether at the site or in CONTRACTOR's principal or a branch office for general administration of the work, or not specifically covered by paragraph 11.3, all of which are to be considered administrative costs covered by the CONTRACTOR's fee.
- B. Expenses of CONTRACTOR's principal and branch offices other than CONTRACTOR's office at the site.
- C. Any part of CONTRACTOR's capital expenses, including interest on CONTRACTOR's capital employed for the WORK and charges against CONTRACTOR for delinquent payments.
- D. Cost of premiums for all bonds and for all insurance whether or not CONTRACTOR is required by the Contract Documents to purchase and maintain the same (except for the cost of premiums covered by paragraph 11.4 above).
- E. Costs due to the negligence of CONTRACTOR , any Subcontractor, or anyone directly or indirectly employed by any of them or for whose acts any of them may be liable, including but not limited to, the correction of Defective WORK, disposal of materials or equipment wrongly supplied and making good any damage to property.
- F. Other overhead or general expense costs of any kind and the cost of any item not specifically and expressly included in paragraph 11.4.

## SECTION 00700 - GENERAL CONDITIONS

### ARTICLE 12 CHANGE OF CONTRACT TIME

#### 12.1 GENERAL

- A. The Contract Time may only be changed by a Change Order. Any claim for an extension of the Contract Time (or Milestones) shall be based on written notice delivered by the CONTRACTOR to the ENGINEER promptly (but in no event later than 30 days) after the occurrence of the event giving rise to the claim and stating the general nature of the claim. Notice of the extent of the claim with supporting data shall be delivered within 60 days after such occurrence (unless the ENGINEER allows an additional period of time to ascertain more accurate data in support of the claim) and shall be accompanied by the CONTRACTOR's written statement that the adjustment claimed is the entire adjustment to which the CONTRACTOR has reason to believe it is entitled as a result of the occurrence of said event. All claims for adjustment in the Contract Time shall be determined by the ENGINEER in accordance with Paragraph 9.8 if the OWNER and the CONTRACTOR cannot otherwise agree. No claim for an adjustment in the Contract Time will be valid if not submitted in accordance with the requirements of this Paragraph 12.1A. An increase in Contract Time does not mean that the Contractor is due an increase in Contract Price. Only compensable time extensions will result in an increase in Contract Price.
- B. All time limits stated in the Contract Documents are of the essence of the Agreement.
- C. Where CONTRACTOR is prevented from completing any part of the WORK within the Contract Times (or Milestones) due to delay beyond the control of CONTRACTOR, the Contract Times (or Milestones) will be extended in an amount equal to the time lost on the critical path of the project due to such delay if a claim is made therefor as provided in paragraph 12.1. Delays beyond the control of CONTRACTOR shall include, but not be limited to, acts or neglect by OWNER, acts or neglect of utility owners or other contractors performing other work as contemplated by Article 7, fires, floods, epidemics, unprecedented weather conditions or acts of God. Delays attributable to and within the control of a Subcontractor or Supplier shall be deemed to be delays within the control of CONTRACTOR.
- D. Where CONTRACTOR is prevented from completing any part of the WORK within the Contract Times (or Milestones) due to delay beyond the control of both OWNER and CONTRACTOR, an extension of the Contract Times (or Milestones) in an amount equal to the time lost on the critical path of the project due to such delay shall be CONTRACTOR's sole and exclusive remedy for such delay. In no event shall the OWNER be liable to CONTRACTOR, any Subcontractor, any Supplier, or any other person or organization, or to any surety for or employee or agent of any of them, for damages arising out of or resulting from (i) delays caused by or within the control of CONTRACTOR, or (ii) delays beyond the control of both parties including but not limited to fires, floods, epidemics abnormal weather conditions, acts of God or acts or neglect by utility owners or other contractors performing other work as contemplated by Article 7.

12.2 EXTENSIONS OF TIME FOR DELAY DUE TO WEATHER. Contract Time may be extended by the ENGINEER because of delays in completion of the WORK due to unusually severe weather, provided that the CONTRACTOR shall, within 10 days of the beginning of any such delay, notify the ENGINEER in writing of the cause of delay and request an extension of Contract Time. The

## SECTION 00700 - GENERAL CONDITIONS

ENGINEER will ascertain the facts and the extent of the delay and extend the time for completing the work when, in the ENGINEER's judgment, the findings of fact justify such an extension. Unprecedented, abnormal, or unusually severe weather will be defined as an event, or events, with a greater than 50-year recurrence interval, as determined by the National Weather Service, or equivalent State or Federal agency

### ARTICLE 13 WARRANTY AND GUARANTEE; TESTS AND INSPECTIONS; CORRECTION, REMOVAL, OR ACCEPTANCE OF DEFECTIVE WORK

- 13.1 **WARRANTY AND GUARANTEE.** The CONTRACTOR warrants and guarantees to the OWNER and the ENGINEER that all work will be in accordance with the Contract Documents and will not be defective. Prompt notice of defects known to the OWNER or ENGINEER shall be given to the CONTRACTOR. All defective work, whether or not in place, may be rejected, corrected, or accepted as provided in this Article 13.
- 13.2 **ACCESS TO WORK.** OWNER, ENGINEER, their Consultants, sub-consultants, other representatives and personnel of OWNER, independent testing laboratories and governmental agencies with jurisdictional interests will have access to the WORK at reasonable times for their observation, inspecting and testing. CONTRACTOR shall provide them proper and safe conditions for such access and advise them of CONTRACTOR's site safety procedures and programs so that they may comply therewith as applicable.
- 13.3 **TESTS AND INSPECTIONS**
- A. The CONTRACTOR shall give the ENGINEER timely notice of readiness of the WORK for all required inspections, tests, or approvals, and shall cooperate with inspection and testing personnel to facilitate required inspections or tests.
  - B. If Laws or Regulations of any public body having jurisdiction other than the OWNER require any WORK to specifically be inspected, tested, or approved, the CONTRACTOR shall pay all costs in connection therewith. The CONTRACTOR shall also be responsible for and shall pay all costs in connection with any inspection or testing required in connection with the OWNER's or the ENGINEER's acceptance of a Supplier of materials or equipment proposed as a substitution or (or-equal) to be incorporated in the WORK, or of materials or equipment submitted for review prior to the CONTRACTOR's purchase thereof for incorporation in the WORK. The cost of all inspections, tests, and approvals in addition to the above which are required by the Contract Documents shall be paid by the OWNER (unless otherwise specified).
  - C. The ENGINEER will make, or have made, such inspections and tests as the ENGINEER deems necessary to see that the WORK is being accomplished in accordance with the requirements of the Contract Documents. Unless otherwise specified in the Supplementary General Conditions, the cost of such inspection and testing will be borne by the OWNER. In the event such inspections or tests reveal non-compliance with the requirements of the Contract Documents, the CONTRACTOR shall bear the cost of corrective measures deemed necessary by the ENGINEER, as well as the cost of subsequent reinspection and retesting. Neither observations by the ENGINEER nor inspections, tests, or approvals by others shall relieve the CONTRACTOR from the CONTRACTOR's obligation to perform the WORK in accordance with the Contract Documents.

## SECTION 00700 - GENERAL CONDITIONS

- D. All inspections, tests, or approvals other than those required by Laws or Regulations of any public body having jurisdiction shall be performed by organizations acceptable to the ENGINEER and the CONTRACTOR.
  - E. If any WORK (including the work of others) that is to be inspected, tested, or approved is covered without written concurrence of the ENGINEER, it must, if requested by the ENGINEER, be uncovered for observation. Such uncovering shall be at the CONTRACTOR's expense unless the CONTRACTOR has given the ENGINEER timely notice of the CONTRACTOR's intention to perform such test or to cover the same and the ENGINEER has not acted with reasonable promptness in response to such notice.
  - F. If any WORK is covered contrary to the written request of the ENGINEER, it must, if requested by the ENGINEER, be uncovered for the ENGINEER's observation and recovered at the CONTRACTOR's expense.
  - G. If the ENGINEER considers it necessary or advisable that covered WORK be observed by the ENGINEER or inspected or tested by others, the CONTRACTOR, at the ENGINEER's request, shall uncover, expose, or otherwise make available for observation, inspection, or testing as the ENGINEER may require, that portion of the WORK in question, furnishing all necessary labor, material, and equipment. If it is found that such WORK is defective, the CONTRACTOR shall bear all direct, indirect, and consequential costs and damages of such uncovering, exposure, observation, inspection, and testing and of satisfactory reconstruction, including but not limited to fees and charges of engineers, attorneys, and other professionals. However, if such WORK is not found to be defective, the CONTRACTOR shall be allowed an increase in the Contract Price or an extension of the Contract Time, or both, directly attributable to such uncovering, exposure, observation, inspection, testing, and reconstruction; and, if the parties are unable to agree as to the amount or extent thereof, the CONTRACTOR may make a claim therefor as provided in Articles 11 and 12.
- 13.4 OWNER MAY STOP THE WORK. If the WORK is defective, or the CONTRACTOR fails to perform work in such a way that the completed WORK will conform to the Contract Documents, the OWNER may order the CONTRACTOR to stop the WORK, or any portion thereof, until the cause for such order has been eliminated; however, this right of the OWNER to stop the WORK shall not give rise to any duty on the part of the OWNER to exercise this right for the benefit of the CONTRACTOR or any other party.
- 13.5 CORRECTION OR REMOVAL OF DEFECTIVE WORK. If required by the ENGINEER, the CONTRACTOR shall promptly, either correct all defective work, whether or not fabricated, installed, or completed, or, if the WORK has been rejected by the ENGINEER, remove it from the site and replace it with non-defective work. The CONTRACTOR shall bear all direct, indirect and consequential costs and damages of such correction or removal, including but not limited to fees and charges of engineers, attorneys, and other professionals made necessary thereby.

## SECTION 00700 - GENERAL CONDITIONS

### 13.6 ONE YEAR CORRECTION PERIOD

- A. If within one year after the date of Substantial Completion or such longer period of time as may be prescribed by Laws or Regulations or by the terms of any applicable special guarantee required by the Contract Documents or by any specific provision of the Contract Documents, any work is found to be defective, the CONTRACTOR shall promptly, without cost to the OWNER and in accordance with OWNER's written notification, (i) correct such Defective WORK, or, if it has been rejected by the OWNER, remove it from the site and replace it with non-defective work, and (ii) satisfactorily correct or remove and replace any damage to other work of others resulting therefrom. If the CONTRACTOR does not promptly comply with such notification, or in an emergency where delay would cause serious risk of loss or damage, the OWNER may have the Defective WORK corrected or the rejected WORK removed and replaced, and all direct, indirect, and consequential costs and damages of such removal and replacement including but not limited to fees and charges of engineers, attorneys and other professionals will be paid by the CONTRACTOR.
- B. Where Defective WORK (and damage to other WORK resulting therefrom) has been corrected, removed or replaced under this paragraph 13.6, the correction period hereunder with respect to such WORK will be extended for an additional period of one year after such correction or removal and replacement has been satisfactorily completed.

13.7 ACCEPTANCE OF DEFECTIVE WORK. If, instead of requiring correction or removal and replacement of defective work, the OWNER prefers to accept the WORK, the OWNER may do so. The CONTRACTOR shall bear all direct, indirect, and consequential costs attributable to the OWNER's evaluation of and determination to accept such defective work. If any such acceptance occurs prior to final payment, a Change Order will be issued incorporating the necessary revisions in the Contract Documents with respect to the WORK, and the OWNER shall be entitled to an appropriate decrease in the Contract Price.

## ARTICLE 14 PAYMENTS TO CONTRACTOR AND COMPLETION

14.1 SCHEDULE OF VALUES (LUMP SUM PRICE BREAKDOWN). The schedule of values or lump sum price breakdown established as provided in the General Requirements shall serve as the basis for progress payments and will be incorporated into a form of Application for Payment acceptable to the ENGINEER.

14.2 UNIT PRICE BID SCHEDULE. Progress payments on account of Unit Price work will be based on the number of units completed.

### 14.3 APPLICATION FOR PROGRESS PAYMENT

- A. Unless otherwise prescribed by law, on the 25th of each month, the CONTRACTOR shall submit to the ENGINEER for review, an Application for Payment filled out and signed by the CONTRACTOR covering the WORK completed as of the date of the Application and accompanied by such supporting documentation as is required by the Contract Documents.
- B. The Application for Payment shall identify, as a sub-total, the amount of the CONTRACTOR'S Total Earnings to Date, plus the Value of Materials Stored at the Site which have not yet been incorporated in the WORK, and less a deductive adjustment for

## SECTION 00700 - GENERAL CONDITIONS

materials installed which were not previously incorporated in the WORK, but for which payment was allowed under the provisions for payment for Materials Stored at the Site, but not yet incorporated in the WORK.

- C. The Net Payment Due the CONTRACTOR shall be the above-mentioned subtotal from which shall be deducted the total amount of all previous payments made to the CONTRACTOR. Progress payments will be paid in full in accordance with Article 14 of the General Conditions until 90% of the Contract Price has been paid. The remaining 10% of the Contract Price amount may be withheld until:

1. final inspection has been made;
2. completion of the Project; and
3. acceptance of the Project by the OWNER.

- D. The Value of Materials Stored at the Site shall be an amount equal to the specified percent of the value of such materials as set forth in the Supplementary General Conditions. Said amount shall be based upon the value of all acceptable materials and equipment not incorporated in the WORK but delivered and suitably stored at the site or at another location agreed to in writing; provided, each such individual item has a value of more than \$5,000.00 and will become a permanent part of the WORK. The Application for Payment shall also be accompanied by an invoice (including shipping), a certification that the materials meet the applicable contract specifications, and any evidence required by the OWNER that the materials and equipment are covered by appropriate property insurance and other arrangements to protect the OWNER's interest therein, all of which will be satisfactory to the OWNER. Payment for materials will not constitute final acceptance. It shall be the CONTRACTOR's responsibility to protect the material from damage, theft, loss, or peril while in storage. Unless otherwise prescribed by law, the Value of Materials Stored at the Site shall be paid at the invoice amount up to a maximum of 85% of the Contract Price for those items.

- 14.4 CONTRACTOR'S WARRANTY OF TITLE. The CONTRACTOR warrants and guarantees that title to all work, materials, and equipment covered by an Application for Payment, whether incorporated in the WORK or not, will pass to the OWNER no later than the time of payment free and clear of all liens.

### 14.5 REVIEW OF APPLICATIONS FOR PROGRESS PAYMENT

- A. The ENGINEER will, within 7 days after receipt of each Application for Payment, either indicate in writing a recommendation of payment and present the Application to the OWNER, or return the Application to the CONTRACTOR indicating in writing the ENGINEER's reasons for refusing to recommend payment. In the later case, the CONTRACTOR may make the necessary corrections and resubmit the Application. If the ENGINEER still disagrees with a portion of the Application, it will submit the Application recommending the undisputed portion of the Application to the OWNER for payment and provide reasons for recommending non-payment of the disputed amount. Thirty days after presentation of the Application for Payment with the ENGINEER's recommendation, the amount recommended will (subject to the provisions of Paragraph 14.5B) become due and when due will be paid by the OWNER to the CONTRACTOR.

## SECTION 00700 - GENERAL CONDITIONS

- B. The OWNER may refuse to make payment of the full amount recommended by the ENGINEER because claims have been made against the OWNER on account of the CONTRACTOR's performance of the WORK or Liens have been filed in connection with the WORK or there are other items entitling the OWNER to a credit against the amount recommended, but the OWNER must give the CONTRACTOR written notice within 7 days (with a copy to the ENGINEER) stating the reasons for such action.

### 14.6 PARTIAL UTILIZATION

- A. The OWNER shall have the right to utilize or place into service any item of equipment or other usable portion of the WORK prior to completion of the WORK. Whenever the OWNER plans to exercise said right, the CONTRACTOR will be notified in writing by the OWNER, identifying the specific portion or portions of the WORK to be so utilized or otherwise placed into service.
- B. It shall be understood by the CONTRACTOR that until such written notification is issued, all responsibility for care and maintenance of all of the WORK shall be borne by the CONTRACTOR. Upon issuance of said written notice of partial utilization, the OWNER will accept responsibility for the protection and maintenance of all such items or portions of the WORK described in the written notice.
- C. The CONTRACTOR shall retain full responsibility for satisfactory completion of the WORK, regardless of whether a portion thereof has been partially utilized by the OWNER and the CONTRACTOR's one year correction period shall commence only after the date of Substantial Completion for the WORK.

- 14.7 SUBSTANTIAL COMPLETION. When the CONTRACTOR considers the WORK ready for its intended use the CONTRACTOR shall notify the OWNER and the ENGINEER in writing that the WORK is substantially complete. The CONTRACTOR will attach to this request a list of all work items that remain to be completed and a request that the ENGINEER prepare a Notice of Completion. Within a reasonable time thereafter, the OWNER, the CONTRACTOR, and the ENGINEER shall make an inspection of the WORK to determine the status of completion. If the ENGINEER does not consider the WORK substantially complete, or the list of remaining work items to be comprehensive, the ENGINEER will notify the CONTRACTOR in writing giving the reasons therefor. If the ENGINEER considers the WORK substantially complete, the ENGINEER will prepare and deliver to the OWNER, for its execution and recording, the Notice of Completion signed by the ENGINEER and CONTRACTOR, which shall fix the date of Substantial Completion.

- 14.8 FINAL APPLICATION FOR PAYMENT. After the CONTRACTOR has completed all of the remaining work items referred to in Paragraph 14.7 and delivered all maintenance and operating instructions, schedules, guarantees, Bonds, certificates of inspection, record as-built documents (as provided in the General Requirements) and other documents, all as required by the Contract Documents, and after the ENGINEER has indicated that the WORK is acceptable, the CONTRACTOR may make application for final payment following the procedure for progress payments. The final Application for Payment shall be accompanied by all documentation called for in the Contract Documents, together with complete and legally effective releases or waivers (satisfactory to the OWNER) of all liens arising out of or filed in connection with the WORK.



## SECTION 00700 - GENERAL CONDITIONS

### 14.9 FINAL PAYMENT AND ACCEPTANCE

- A. If, on the basis of the ENGINEER's observation of the WORK during construction and final inspection, and the ENGINEER's review of the final Application for Payment and accompanying documentation, all as required by the Contract Documents, the ENGINEER is satisfied that the WORK has been completed and the CONTRACTOR's other obligations under the Contract Documents have been fulfilled, the ENGINEER will, within 14 days after receipt of the final Application for Payment, indicate in writing the ENGINEER's recommendation of payment and present the Application to the OWNER for payment.
- B. After acceptance of the WORK by the OWNER's governing body, the OWNER will make final payment to the CONTRACTOR of the amount remaining after deducting all prior payments and all amounts to be kept or retained under the provisions of the Contract Documents, including the following items:
  - 1. Liquidated damages, as applicable.
  - 2. Two times the value of outstanding items of correction work or punch list items yet uncompleted or uncorrected, as applicable. All such work shall be completed or corrected to the satisfaction of the OWNER within the time stated on the Notice of Completion, otherwise the CONTRACTOR does hereby waive any and all claims to all monies withheld by the OWNER to cover the value of all such uncompleted or uncorrected items.

### 14.10 RELEASE OF RETAINAGE AND OTHER DEDUCTIONS

- A. After executing the necessary documents to initiate the lien period, and not more than 45 days thereafter (based on a 30-day lien filing period and 15-day processing time), the OWNER will release to the CONTRACTOR the retainage funds withheld pursuant to the Agreement, less any deductions to cover pending claims against the OWNER pursuant to Paragraph 14.5B.
- B. After filing of the necessary documents to initiate the lien period, the CONTRACTOR shall have 30 days to complete any outstanding items of correction work remaining to be completed or corrected as listed on a final punch list made a part of the Notice of Completion. Upon expiration of the 45 days, referred to in Paragraph 14.10A, the amounts withheld pursuant to the provisions of Paragraph 14.9B herein, for all remaining work items will be returned to the CONTRACTOR; provided, that said work has been completed or corrected to the satisfaction of the OWNER within said 30 days. Otherwise, the CONTRACTOR does hereby waive any and all claims for all monies withheld by the OWNER under the Contract to cover 2 times the value of such remaining uncompleted or uncorrected items.

- 14.11 CONTRACTOR'S CONTINUING OBLIGATION. The CONTRACTOR's obligation to perform and complete the WORK in accordance with the Contract Documents shall be absolute. Neither recommendation of any progress or final payment by the ENGINEER, nor the issuance of a Notice of Completion, nor any payment by the OWNER to the CONTRACTOR under the Contract Documents, nor any use or occupancy of the WORK or any part thereof by the OWNER, nor any act of acceptance by the OWNER nor any failure to do so, nor any review of a Shop Drawing or sample submittal, will constitute an acceptance of work not in accordance with the Contract Documents or a release of the CONTRACTOR's obligation to perform the WORK in accordance with the Contract Documents.

## SECTION 00700 - GENERAL CONDITIONS

- 14.12 FINAL PAYMENT TERMINATES LIABILITY OF OWNER. Final payment is defined as the last progress payment made to the CONTRACTOR for earned funds, less monies withheld as applicable, pursuant to Paragraph 14.10A. The acceptance by the CONTRACTOR of the final payment referred to in Paragraph 14.9 herein, shall be a release of the OWNER and its agents from all claims of liability to the CONTRACTOR for anything done or furnished for, or relating to, the WORK or for any act of neglect of the OWNER or of any person relating to or affecting the WORK, except demands against the OWNER for the remainder, if any, of the amounts kept or retained under the provisions of Paragraph 14.9 herein; and excepting pending, unresolved claims filed prior to the date of the Notice of Completion.

### ARTICLE 15 SUSPENSION OF WORK AND TERMINATION

- 15.1 SUSPENSION OF WORK BY OWNER. The OWNER, acting through the ENGINEER, may, at any time and without cause, suspend the WORK or any portion thereof for a period of not more than 90 days by notice in writing to the CONTRACTOR. The CONTRACTOR shall resume the WORK on receipt from the ENGINEER of a notice of resumption of work. The CONTRACTOR shall be allowed an increase in the Contract Price or an extension of the Contract Time, or both, directly attributable to any suspension if the CONTRACTOR makes an approved claim therefor as provided in Articles 11 and 12.
- 15.2 TERMINATION OF AGREEMENT BY OWNER (CONTRACTOR DEFAULT)
- A. In the event of default by the CONTRACTOR, the OWNER may give 10 days written notice to the CONTRACTOR of OWNER's intent to terminate the Agreement and provide the CONTRACTOR an opportunity to remedy the conditions constituting the default. It shall be considered a default by the CONTRACTOR whenever CONTRACTOR shall: (1) declare bankruptcy, become insolvent, or assign its assets for the benefit of its creditors; (2) fail to provide materials or quality of work meeting the requirements of the Contract Documents; (3) disregard or violate provisions of the Contract Documents or ENGINEER's instructions; (4) fail to prosecute the WORK according to the approved progress schedule; or, (5) fail to provide a qualified superintendent, competent workers, or materials or equipment meeting the requirements of the Contract Documents. If the CONTRACTOR fails to remedy the conditions constituting default within the time allowed, the OWNER may then issue the Notice of Termination.
- B. In the event the Agreement is terminated in accordance with Paragraph 15.2A, herein, the OWNER may take possession of the WORK and may complete the WORK by whatever method or means the OWNER may select. The cost of completing the WORK shall be deducted from the balance which would have been due the CONTRACTOR had the Agreement not been terminated and the WORK completed in accordance with the Contract Documents. If such cost exceeds the balance which would have been due, the CONTRACTOR shall pay the excess amount to the OWNER. If such cost is less than the balance which would have been due, the CONTRACTOR shall not have claim to the difference.
- 15.3 TERMINATION OF AGREEMENT BY OWNER (FOR CONVENIENCE). The OWNER may terminate the Agreement at any time if it is found that reasons beyond the control of either the OWNER or CONTRACTOR make it impossible or against the OWNER's interests to complete the WORK. In such a case, the CONTRACTOR shall have no claims against the OWNER except: (1) for

## SECTION 00700 - GENERAL CONDITIONS

the value of work performed up to the date the Agreement is terminated; and, (2) for the cost of materials and equipment on hand, in transit, or on definite commitment, as of the date the Agreement is terminated which would be needed in the WORK and which meet the requirements of the Contract Documents. The value of work performed and the cost of materials and equipment delivered to the site, as mentioned above, shall be determined by the ENGINEER in accordance with the procedure prescribed for the making of the final application for payment and payment under Paragraphs 14.8 and 14.9.

- 15.4 TERMINATION OF AGREEMENT BY CONTRACTOR. The CONTRACTOR may terminate the Agreement upon 10 days written notice to the OWNER, whenever: 1) the WORK has been suspended under the provisions of Paragraph 15.1, herein, for more than 90 consecutive days through no fault or negligence of the CONTRACTOR, and notice to resume work or to terminate the Agreement has not been received from the OWNER within this time period; or, 2) the OWNER should fail to pay the CONTRACTOR any monies due him in accordance with the terms of the Contract Documents and within 60 days after presentation to the OWNER by the CONTRACTOR of a request therefor, unless within said 10-day period the OWNER shall have remedied the condition upon which the payment delay was based. In the event of such termination, the CONTRACTOR shall have no claims against the OWNER except for those claims specifically enumerated in Paragraph 15.3, herein, and as determined in accordance with the requirements of said paragraph.

### ARTICLE 16 MISCELLANEOUS

- 16.1 GIVING NOTICE. Whenever any provision of the Contract Documents requires the giving of written notice, it will be deemed to have been validly given if delivered in person to the individual or to a member of the firm or to an officer of the corporation for whom it is intended, or if delivered at or sent by registered or certified mail, postage prepaid, to the last business address known to the giver of the notice.
- 16.2 RIGHTS IN AND USE OF MATERIALS FOUND ON THE WORK
- A. The CONTRACTOR may use on the Project, with ENGINEER's approval, such stone, gravel, sand, or other material determined suitable by the ENGINEER, as may be found in the excavation. The CONTRACTOR will be paid for the excavation of such material at the corresponding contract unit price. No additional payment will be made for utilizing the material from excavation as borrow, or select borrow.
  - B. The CONTRACTOR shall replace, at its own expense, with other acceptable material, all of that portion of the excavated material so removed and used which was needed for use on the project. No charge for the materials so used will be made against the CONTRACTOR except that the CONTRACTOR shall be responsible for payment of any royalties required.
  - C. The CONTRACTOR shall not excavate or remove any material from within the Project location which is not within the grading limits, as indicated by the slope and grade lines, without written authorization from the ENGINEER.
  - D. In the event the CONTRACTOR has processed materials from OWNER-furnished sources in excess of the quantities required for performance of this contract, including any waste material produced as a by-product, the CBJ may retain possession of such materials without obligation to reimburse the CONTRACTOR for the cost of their production. When such

## SECTION 00700 - GENERAL CONDITIONS

materials are in a stockpile, the ENGINEER may require: That it remain in stockpile; the CONTRACTOR level such stockpile(s); or that the CONTRACTOR remove such materials and restore the premises to a satisfactory condition at the CONTRACTOR's expense. This provision shall not preclude the CBJ from arranging with the CONTRACTOR to produce material over and above the contract needs, payment for which shall be by written agreement between the CBJ and the CONTRACTOR.

- E. Unless otherwise provided, the material from any existing old structure may be used temporarily by the CONTRACTOR in the erection of the new structure. Such material shall not be cut or otherwise damaged except with the approval of the ENGINEER.
- 16.3 RIGHT TO AUDIT. If the CONTRACTOR submits a claim to the OWNER for additional compensation, the OWNER shall have the right, as a condition to considering the claim, and as a basis for evaluation of the claim, and until the claim has been settled, to audit the CONTRACTOR's books to the extent they are relevant. This right shall include the right to examine books, records, documents, and other evidence and accounting procedures and practices, sufficient to discover and verify all direct and indirect costs of whatever nature claimed to have been incurred or anticipated to be incurred and for which the claim has been submitted. The right to audit shall include the right to inspect the CONTRACTOR's plants, or such parts thereof, as may be or have been engaged in the performance of the WORK. The CONTRACTOR further agrees that the right to audit encompasses all subcontracts and is binding upon Subcontractors. The rights to examine and inspect herein provided for shall be exercisable through such representatives as the OWNER deems desirable during the CONTRACTOR's normal business hours at the office of the CONTRACTOR. The CONTRACTOR shall make available to the OWNER for auditing, all relevant accounting records and documents, and other financial data, and upon request, shall submit true copies of requested records to the OWNER.
- 16.4 ARCHEOLOGICAL OR HISTORICAL DISCOVERIES. When the CONTRACTOR's operation encounters prehistoric artifacts, burials, remains of dwelling sites, paleontological remains, such as shell heaps, land or sea mammal bones or tusks, or other items of historical significance, the CONTRACTOR shall cease operations immediately and notify the ENGINEER. No artifacts or specimens shall be further disturbed or removed from the ground and no further operations shall be performed at the site until so directed. Should the ENGINEER order suspension of the CONTRACTOR's operations in order to protect an archaeological or historical finding, or order the CONTRACTOR to perform extra work, such order(s) shall be covered by an appropriate contract change document.
- 16.5 CONSTRUCTION OVER OR ADJACENT TO NAVIGABLE WATERS. All work over, on, or adjacent to navigable waters shall be so conducted that free navigation of the waterways will not be interfered with and the existing navigable depths will not be impaired, except as allowed by permit issued the U.S. Coast Guard and/or the U.S. Army Corps of Engineers, as applicable.
- 16.6 GRATUITY AND CONFLICT OF INTEREST. The CONTRACTOR agrees to not extend any loan, gratuity or gift of money of any form whatsoever to any employee or elected official of the OWNER, nor will the CONTRACTOR rent or purchase any equipment or materials from any employee or elected official of the OWNER, or to the best of the CONTRACTOR's knowledge, from any agent of any employee or elected official of the OWNER. Before final payment, the CONTRACTOR shall execute and furnish the OWNER an affidavit certifying that the CONTRACTOR has complied with the above provisions of the contract.

## SECTION 00700 - GENERAL CONDITIONS

### 16.7 SUITS OF LAW CONCERNING THE WORK

- A. Should a suit of law be entered into, either by the CONTRACTOR (or the CONTRACTOR's surety) against the OWNER, or by the OWNER against the CONTRACTOR (or the CONTRACTOR's surety), the suit of law shall be tried in the First Judicial District of Alaska.
- B. If one of the questions at issue is the satisfactory performance of the work by the CONTRACTOR and should the appropriate court of law judge the work of the CONTRACTOR to be unsatisfactory, then the CONTRACTOR (or the CONTRACTOR's surety) shall reimburse the OWNER for all legal and all other expenses (as may be allowed and set by the court) incurred by the OWNER because of the suit of the law and, further, it is agreed that the OWNER may deduct such expense from any sum or sums then, or any that become due the CONTRACTOR under the contract.

### 16.8 CERTIFIED PAYROLLS

- A. All CONTRACTORs or Subcontractor who perform work on a public construction contract for the OWNER shall file a certified payroll with the Alaska Department of Labor before Friday of each week that covers the preceding week (Section 14-2-4 ACLA 1949; am Section 4 ch 142 SLA 1972).
- B. In lieu of submitting the State payroll form, the CONTRACTOR's standard payroll form may be submitted, provided it contains the information required by AS 36.05.040 and a statement that the CONTRACTOR is complying with AS 36.10.010.
- C. A contractor or subcontractor, who performs work on public construction in the State, as defined by AS 36.95.010(3), shall pay not less than the current prevailing rate of wages as issued by the Alaska Department of Labor before the end of the pay period. (AS 36.05.010).

### 16.9 PREVAILING WAGE RATES

- A. Wage rates for Laborers and Mechanics on Public Contracts, AS 36.05.070. The CONTRACTOR, or Subcontractors, shall pay all employees unconditionally and not less than once a week. Wages may not be less than those stated in Paragraph 16.8C, regardless of the contractual relationship between the CONTRACTOR or Subcontractors and laborers, mechanics, or field surveyors. The scale of wages to be paid shall be posted by the CONTRACTOR in a prominent, easily accessible place at the site of the WORK.
- B. Failure to Pay Agreed Wages, AS 36.05.080. If it is found that a laborer, mechanic, or field surveyor employed by the CONTRACTOR or Subcontractor has been, or is being, paid a rate or wages less than the established rate, the OWNER may, by written notice, terminate the CONTRACTOR or Subcontractors right to proceed with the work. The OWNER may prosecute the work to completion by contract or otherwise, and the CONTRACTOR and sureties will be held liable to the OWNER for excess costs for completing the WORK. (Section 2 ch 52 SLA 1959).
- C. Listing Contractor's Who Violate Contracts, AS 36.05.090. In addition, a list giving the names of persons who have disregarded the rights of their employees shall be distributed to all departments of State government and all political subdivisions. No person appearing on this

## SECTION 00700 - GENERAL CONDITIONS

list, and no firm, corporation, partnership or association in which the person has an interest, may work as a CONTRACTOR or Subcontractor on a public construction contract for the State, or a political subdivision of the state, until three years after the date of publication of the list. (Section 3 ch 52 SLA 1959; am Section 9 ch 142 SLA).

16.10 EMPLOYMENT REFERENCE. Workers employed in the execution of the contract by the CONTRACTOR or by any Subcontractor under this contract shall not be required or permitted to labor more than 8 hours a day or 40 hours per week in violation of the provisions of the Alaska Wage and Hour Act, Section 23.10.060.

### 16.11 COST REDUCTION INCENTIVE

- A. At any time within 45 days after the date of the Notice of Award, the CONTRACTOR may submit to the ENGINEER in writing, proposals for modifying the plans, specifications, or other requirements of this contract for the sole purpose of reducing the total cost of construction. The cost reduction proposal shall not impair in any manner the essential functions or characteristics of the project, including but not limited to, service life, economy of operation, ease of maintenance, desired appearance or design and safety standards.
- B. The cost reduction proposal shall contain the following information:
1. Description of both the existing contract requirements for performing the WORK and the proposed changes.
  2. An itemization of the contract requirements that must be changed if the proposal is adopted.
  3. A detailed estimate of the time required and the cost of performing the WORK under both the existing contract and the proposed change.
  4. A statement of the date by which the CONTRACTOR must receive the decision from the OWNER on the cost reduction proposal.
  5. The contract items of WORK effected by the proposed changes including any quantity variations.
  6. A description and estimate of costs the OWNER may incur in implementing the proposed changes, such as test and evaluation and operating and support costs.
  7. A prediction of any effects the proposed change would have on future operations and maintenance costs to the OWNER.
- C. The provisions of this section shall not be construed to require the OWNER to consider any cost reduction proposal which may be submitted; nor will the OWNER be liable to the CONTRACTOR for failure to accept or act upon any cost reduction proposal submitted, or for delays to the work attributable to the consideration or implementation of any such proposal.
- D. If a cost reduction proposal is similar to a change in the plans or specifications for the project under consideration by the OWNER at the time the proposal is submitted, the OWNER will not accept such proposal and reserves the right to make such changes without compensation to the CONTRACTOR under the provisions of this section.
- E. The CONTRACTOR shall continue to perform the work in accordance with the requirements of the contract until an executed Change Order incorporating the cost reduction proposal has

## SECTION 00700 - GENERAL CONDITIONS

been issued. If any executed Change Order has not been issued by the date upon which the CONTRACTOR's cost reduction proposal specifies that a decision should be made by the OWNER, in writing, the cost reduction proposal shall be considered rejected.

- F. The OWNER, shall be the sole judge of the acceptability of a cost reduction proposal and of the estimated net savings in Contract Time and construction costs resulting from the adoption of all or any part of such proposal. Should the CONTRACTOR disagree with OWNER's decision on the cost reduction proposal, there is no further consideration. The OWNER reserves the right to make final determination.
- G. If the CONTRACTOR's cost reduction proposal is accepted in whole or in part, such acceptance will be made by a contract Change Order, which specifically states that the change is executed pursuant to this cost reduction proposal section. Such Change Order shall incorporate the changes in the plans and specifications which are necessary to permit the cost reduction proposal or such part of it as has been accepted to be put into effect and shall include any conditions upon which the OWNER's approval is based, if such approval is conditional. The Change Order shall also describe the estimated net savings in the cost of performing the work attributable to the cost reduction proposal, and shall further provide that the contract cost be adjusted by crediting the OWNER with the estimated net savings amount.
- H. Acceptance of the cost reduction proposal and performance of the work does not extend the time of completion of the contract, unless specifically provided in the Change Order authorizing the use of the submitted proposal. Should the adoption of the cost reduction proposal result in a Contract Time savings, the total Contract Time shall be reduced by an amount equal to the time savings realized.
- I. The amount specified to the CONTRACTOR in the Change Order accepted in the cost reduction proposal shall constitute full compensation for the performance of WORK. No claims for additional costs as a result of the changes specified in the cost reduction proposal shall be allowed.
- J. The OWNER reserves the right to adopt and utilize any approved cost reduction proposal for general use on any contract administered when it is determined suitable for such application. Cost reduction proposals identical, similar, or previously submitted will not be accepted for consideration if acceptance and compensation has previously been approved. The OWNER reserves the right to use all or part of any cost reduction proposal without obligation or compensation of any kind to the CONTRACTOR.
- K. The CONTRACTOR shall bear the costs, if any, to revise all bonds and insurance requirements for the project, to include the cost reduction WORK.

**END OF SECTION**

## SECTION 00800 - SUPPLEMENTARY GENERAL CONDITIONS

**GENERAL.** These Supplementary General Conditions make additions, deletions, or revisions to the General Conditions as indicated herein. All provisions which are not so added, deleted, or revised remain in full force and effect. Terms used in these Supplementary General Conditions which are defined in the General Conditions have the meanings assigned to them in the General Conditions.

**SGC 1 DEFINITIONS.** *Remove* the definition for Contract Documents and *replace* with the following:

Contract Documents – The Table of Contents, Notice Inviting Bids, Instructions to Bidders, Bid Forms (including the Bid, Bid Schedule(s), Subcontractor Report, Bid Bond, and all required certificates and affidavits), Agreement, Performance Bond, Payment Bond, General Conditions, Supplementary General Conditions, Alaska Labor Standards, Reporting, and Prevailing Wage Rate Determination, Special Provisions, Standard Specifications, Technical Specifications, Drawings, Permits, and all Addenda, and Change Orders executed pursuant to the provisions of the Contract Documents.

**SGC 2.2 COPIES OF DOCUMENTS.** *Add* the following:

The OWNER shall furnish to the CONTRACTOR two (2) hard copies of the Contract Documents which will include bound reduced Drawings and one (1) electronic copy (pdf format) on a CD-ROM. Additional copies of contract documents are the responsibility of the contractor.

**SGC 3.2 ORDER OF PRECEDENCE OF CONTRACT DOCUMENTS.** *Remove* No. 12. Technical Specifications and No. 13. Drawings, and *add* the following:

12. Special Provisions Section
13. Standard Specifications for Civil Engineering Projects and Subdivision Improvements  
December 2003 Edition with current Errata Sheets.
14. Drawings.

**SGC 4.2 PHYSICAL CONDITIONS - SUBSURFACE AND EXISTING STRUCTURES.** *Add* the following:

- C. In the preparation of the Contract Documents, the Engineer of Record has relied upon field measurements and visual inspection of the existing structures and surface conditions.

**SGC - 4.6 USE OF THE CBJ/STATE LEMON CREEK GRAVEL PIT.** *Add* the following.

**The CBJ/State Lemon Creek Gravel Pit is available for this Project.**

**SGC - 4.6 USE OF THE CBJ/STATE LEMON CREEK GRAVEL PIT.**

Wherever the land use permits are referenced, *delete* and *replace with* the permit number USE2008-00061.

- *Delete* the last sentence of Paragraph A and *replace with* the following: “Contact Alec Venechuck, CBJ Material Source Manager, at (907) 586-0874 for the current material rates.”
- *Delete* paragraph C., and *replace* with the following paragraph C.

- C. CONTRACTORs deciding to use material from the CBJ/State pit shall provide an Individual



## SECTION 00800 - SUPPLEMENTARY GENERAL CONDITIONS

Mining Plan prepared by a professional engineer registered in the State of Alaska. The Individual Mining Plan must be reviewed and approved by the CBJ, prior to commencing operations within the pit. CONTRACTORS shall also secure a Performance Bond to ensure compliance with contract provisions, including any Individual Mining Plan stipulations. The bond shall remain in full force and effect until a release is obtained from the CBJ. A \$10,000 cash processing restoration bond is required prior to screening or primary crushing operations.

➤ **Add** the following paragraphs:

- J. Contractors choosing to mine material from CBJ material sources are also subject to the conditions contained in each site's Multi Sector General Permit for Stormwater Discharges associated with industrial activities (MSGP) and the Storm Water Pollution Prevention Plan (SWPPP).
- K. Contractors choosing to perform screening or primary crushing shall comply with all requirements of Mine Safety and Health Administration (MSHA) Part 46, and must obtain a Contractor ID number (7000-52) from MSHA.

**Add** the following SGC 4.7:

**SGC 4.7 USE OF CITY/STATE STABLER'S POINT ROCK QUARRY.** **Add** the following:

**The CBJ/State Stabler's Point Rock Quarry is not available for this Project.**

**SGC 5.1 PERFORMANCE, PAYMENT, AND OTHER BONDS.** The Contractor shall furnish Performance and Payment Bonds in the amount of 100% of the Bid.

**SGC 5.2 INSURANCE AMOUNTS.** The limits of liability for the insurance required by Paragraph 5.2 of the General Conditions shall provide coverage for not less than the following amounts or greater where required by Laws and Regulations. The CONTRACTOR must provide certification of proper insurance coverage and amendatory endorsements or copies of the applicable policy language affecting coverage required in this agreement to the City and Borough of Juneau. All certificates of insurance supplied to the OWNER shall state that the OWNER is named as **“Additional Insured for any and all work performed for the City & Borough of Juneau” for the Commercial General Liability policy and any other policies, if required in this Section.** NOTE: This requirement has changed. The OWNER no longer requires certificates of insurance referencing project names and contract numbers.

**Delete** paragraph C and **Replace** with the following paragraph C:

- C. The CONTRACTOR shall furnish the OWNER with certificates showing the type, amount, class of operations covered, effective dates and dates of expiration of policies. Failure of CBJ to demand such certificate or other evidence of full compliance with these insurance requirements or failure of CBJ to identify a deficiency from evidence that is provided shall not be construed as a waiver of the obligation of the Contractor to maintain the insurance required by this contract. The coverage afforded will not be cancelled, reduced in coverage, or renewal refused until at least 30 days' prior written notice has been given to the OWNER by the CONTRACTOR. **All such insurance required herein (except for Workers' Compensation and Employer's Liability) shall name the OWNER, its Consultants and subconsultants and their officers, directors, agents, and employees as**

**SECTION 00800 - SUPPLEMENTARY GENERAL CONDITIONS**

**"additional insureds" under the policies.**

The CONTRACTOR shall purchase and maintain the following insurance:

1. Workers' Compensation and Employer's Liability. This insurance shall protect the CONTRACTOR against all claims under applicable state workers' compensation laws. The CONTRACTOR shall also be protected against claims for injury, disease, or death of employees which, for any reason, may not fall within the provisions of a Workers' Compensation law. The CONTRACTOR shall require each Subcontractor similarly to provide Workers' Compensation Insurance for all of the latter's employees to be engaged in such work unless such employees are covered by the protection afforded by the CONTRACTOR's Workers' Compensation Insurance. In case any class of employees is not protected, under the Workers' Compensation Statute, the CONTRACTOR shall provide and shall cause each subcontractor to provide adequate employer's liability insurance for the protection of such of its employees as are not otherwise protected. **The CONTRACTOR grants a waiver of any right to subrogation against the OWNER by virtue of the payment of any loss under such insurance.** This provision applies regardless of whether or not the OWNER has received a waiver of subrogation endorsement from the insurer.

Workers' Compensation: (under Paragraph 5.2C.1 of the General Conditions) as in accordance with AS 23.30.045:

- a. State: Statutory
- b. Applicable Federal (e.g., Longshore): Statutory

Note: If the WORK called for in the Contract Documents involves work in or on any navigable waters, the CONTRACTOR shall provide Workers' Compensation coverage which shall include coverage under the Longshore and Harbor Workers' Compensation Act, the Jones Act, and any other coverage required under Federal or State laws pertaining to workers in or on navigable waters.

- a. Employers Liability
 

Bodily Injury by Accident:	\$100,000.00	Each Accident
Bodily Injury by Disease:	\$100,000.00	Each Employee
Bodily Injury by Disease:	\$500,000.00	Policy Limit

- 1. CONTRACTOR agrees to waive all rights of subrogation against the OWNER for WORK performed under contract.
- 2. If CONTRACTOR directly utilizes labor outside of the State of Alaska in the prosecution of the WORK, "Other States" endorsement shall be required as a condition of the contract.

2. Commercial General Liability (CGL), including products and completed operations, property damage, bodily injury and personal and advertising injury, with limits no less than \$1,000,000 each occurrence and \$2,000,000 aggregate. (under Paragraph 5.2C.2 of the General Conditions) **This insurance policy is to contain, or be endorsed to contain, additional insured status for the CBJ, its officers, officials, employees, and volunteers.** If Additional insured status is provided in the form of an endorsement to the Contractor's insurance, the endorsement shall be at least as broad as ISO Form CG 20 10 11 85 or **both** CG 20 10, CG 20 26, CG 20 33, or CG 20 38; **and** CG 20 37 forms if later revisions used).

**SECTION 00800 - SUPPLEMENTARY GENERAL CONDITIONS**

3. Commercial Automobile Liability: (under Paragraph 5.2C.3 of the General Conditions) including Owned, Hired, and Non-Owned Vehicles:

Combined Single Limit, Bodily Injury and Property Damage \$1,000,000.00

**This insurance policy is to contain, or be endorsed to contain, additional insured status for the CBJ, its officers, officials, employees, and volunteers** The CONTRACTOR shall require each Subcontractor similarly to provide Commercial Automobile Liability Insurance for all of the latter's employees to be engaged in such WORK unless such employees are covered by the protection afforded by the CONTRACTOR's Commercial Automobile Liability Insurance.

*Add* the following paragraphs:

- C. Builder's Risk: CONTRACTOR is not required to obtain a Builder's Risk insurance policy for this project.
- D. All Subcontractors are required to secure and maintain the insurance coverages listed above, unless otherwise noted.
- E. If the CONTRACTOR maintains higher limits than the minimums shown above, the OWNER requires and shall be entitled to coverage for the higher limits maintained by the CONTRACTOR. Any available insurance proceeds in excess of the specified minimum limits of insurance and coverage shall be available to the OWNER.
- F. Policies shall also specify insurance provided by CONTRACTOR will be considered primary and not contributory to any other insurance available to the OWNER.
- G. Should any of the policies described above be cancelled before the expiration date thereof, notice will be delivered in accordance with the policy provisions.

**SGC 6.5 CONCERNING SUBCONTRACTORS, SUPPLIERS, AND OTHERS.** *Add* the following:

B. The CONTRACTOR shall perform not less than 40% of the WORK with its own forces (i.e., without subcontracting). The 40% requirement shall be understood to mean that the CONTRACTOR shall perform, with its own organization, WORK amounting to at least 40% of the original contract amount. The 40% requirement will be calculated based upon the total of the subcontract amounts submitted for Contract Award, and any other information requested by the OWNER from the apparent low Bidder.

**SGC 6.5 CONCERNING SUBCONTRACTORS, SUPPLIERS, AND OTHERS,** *Add* the following paragraph:

- C. CONTRACTOR must pay Subcontractors and/or Suppliers within 30 days of receiving payment from the OWNER, if that payment was made for Work performed by the Subcontractor and/or materials received. Failure to pay Subcontractors within 30 days of receiving payment from which Subcontractor and/or Supplier is to be paid may result in the OWNER initiating debarment proceedings as prescribed

## SECTION 00800 - SUPPLEMENTARY GENERAL CONDITIONS

in the City and Borough of Juneau Purchasing Code. *The 30 day City and Borough of Juneau requirement does not supersede AS 36.90.210.*

**SGC 6.6 PERMITS**, *Add* the following paragraph:

- D. Contractor is responsible for obtaining a Hot Works permit from the CBJ Permit Center, if performing work which requires such a permit. Work requiring a Hot Works Permit includes but is not limited to the following: cutting, welding, Thermit welding, brazing, soldering, grinding, thermal spraying, thawing pipe, installation of torch-applied roof systems or any other similar activity.

**SGC 14.3 APPLICATION FOR PROGRESS PAYMENT**. Paragraph D.

- D. The Value of Materials Stored at the site shall be an amount equal to 85%.

**SGC 14.9 FINAL PAYMENT AND ACCEPTANCE**. *Add* the following paragraph:

- C. Prior to the final payment the CONTRACTOR shall contact the Alaska Department of Labor and Workforce Development (ADOL) and provide the OWNER with clearance from the ADOL for the CONTRACTOR and all Subcontractors that have worked on the Project. This clearance shall indicate that all Employment Security Taxes have been paid. A sample form for this purpose is at the end of this section. The CONTRACTOR shall also submit a "NOTICE OF COMPLETION OF PUBLIC WORKS" signed by ADOL.

**SGC 16.8 CERTIFIED PAYROLLS**. *Change* paragraph A. to read:

- A. All CONTRACTORS or Subcontractors who perform work on a public construction contract for the OWNER shall file a certified payroll with Alaska Department of Labor. See Section 00830 - Alaska Labor Standards, Reporting, and Prevailing Wage Rate Determination.

*Add* the following SGC 17:

**SGC 17 GENERAL INFORMATION**. This Project is currently funded by the City and Borough of Juneau, Alaska.

**END OF SECTION**



## Tax Clearance Request Form for Contractors

Date of request: \_\_\_\_\_

Business name of the contractor a Tax Clearance is being requested for: \_\_\_\_\_

Business address: \_\_\_\_\_

Business contact phone number: \_\_\_\_\_

Federal Identification Number: \_\_\_\_\_

Alaska Employer Account Number: \_\_\_\_\_

Specific time period a tax clearance is being requested for (*i.e. beginning and ending date of a subcontract agreement*):

Subcontract project name: \_\_\_\_\_

Name and address of the person this Tax Clearance is to be returned to: \_\_\_\_\_

Comments or additional information: \_\_\_\_\_

For agency use only:

- Tax Clearance is granted
- Tax Clearance is not granted (*please have employer contact the department*)
- No account on file, liability unknown (*please have employer contact the department*)
- Employer has stated no employees, Tax Clearance not required.

Agency representative signature: \_\_\_\_\_ Date: \_\_\_\_\_

Agency representative title: \_\_\_\_\_

**SECTION 00830 - ALASKA LABOR STANDARDS, REPORTING, AND  
PREVAILING WAGE RATE DETERMINATION**

State of Alaska, Department of Labor, Laborers' and Mechanics' Minimum Rates of Pay, AS 36.05.010 and AS 36.05.050, Wage and Hour Administration Pamphlet No. 600, the latest edition published by the State of Alaska, Department of Labor inclusive, are made a part of this contract by reference.

The CONTRACTOR is responsible for contacting the Alaska Department of Labor to determine compliance with current regulations.

Correspondence regarding Title 36 requirements may be submitted electronically or paper copies can be submitted by mail. To submit Title 36 documents electronically, go to <https://myalaska.state.ak.us/home/app>. If filing electronically, submit certified payrolls to ADOL at the website above and email a copy of all certified payrolls to Greg Smith at the email address below. If Contractor elects to submit paper copies, they should be submitted to the physical addresses below.

**Within 10 Days of "Notice of Award/Notice to Proceed"** make a list of **all** Subcontractors. Include their name, address, phone, estimated subcontract amount, and estimated start and finish dates. Send this list to the Wage and Hour Section (contact information below).

**Certified Payrolls must be submitted every two weeks. Before the second Friday**, each CONTRACTOR and Subcontractor must file Certified Payrolls with Statements of Compliance for the previous two weeks. Indicate **"Start"** on your first payroll, and **"Final"** on your last payroll for this Project.

As part of the **final payment request package**, CONTRACTOR must submit a "NOTICE OF COMPLETION OF PUBLIC WORKS" form signed by ADOL personnel.

**Contact Information:**

***Wage and Hour Section***  
State of Alaska  
Department of Labor and Workforce Development  
Labor Standards and Safety Division                      and  
Wage and Hour Administration  
P.O. Box 11149  
Juneau, AK 99811-1149  
907-465-4842  
<http://labor.state.ak.us/lss/home.htm>

***Greg Smith, Contract Administrator***  
City and Borough of Juneau  
155 S. Seward Street  
Juneau, AK 99801  
(907) 586-0873  
[Greg.Smith@juneau.org](mailto:Greg.Smith@juneau.org)

**END OF SECTION**

# SECTION 00830

## APPENDIX A

Laborers' & Mechanics'  
Minimum Rates of Pay

Pamphlet 600

Effective April 2021





PAMPHLET No. 600

Title 36. Public Contracts  
AS 36.05

# Laborers' and Mechanics' MINIMUM RATES OF PAY

Effective April 1, 2021

Issue 42

DEPARTMENT OF LABOR  
AND WORKFORCE DEVELOPMENT  
Wage and Hour Administration



- This page intentionally left blank -



April 1, 2021

**TO ALL CONTRACTING AGENCIES:**

At the Alaska Department of Labor and Workforce Development, our goal is putting Alaskans to work. This pamphlet is designed to help contractors awarded public construction contracts understand the most significant laws of the State of Alaska pertaining to prevailing wage.

This pamphlet identifies current prevailing wage rates for public construction contracts (any construction projects awarded for the State of Alaska or its political subdivisions, such as local governments and certain non-profit organizations). Because these rates may change in a subsequent determination, please be sure you are using the appropriate rates. The rates published in this edition become effective April 1, 2021.

The prevailing wage rates contained in this pamphlet are applicable to public construction projects with a final bid date of April 11, 2021, or later. As the law now provides, these rates will remain stable during the life of a contract or for 24 calendar months, whichever is shorter. **The 24-month period begins on the date the prime contract is awarded.** Upon expiration of the initial 24-month period, the latest wage rates issued by the department shall become effective for a subsequent 24-month period or until the original contract is completed, whichever occurs first. This process shall be repeated until the original contract is completed.

The term "original contract" means the signed contract that resulted from the original bid and any amendments, including changes of work scope, additions, extensions, change orders, and other instruments agreed to by the parties that have not been subject to subsequent open bid procedures.

If a higher federal rate is required due to partial federal funding or other federal participation, the higher rate must be paid.

For additional copies of this pamphlet go to: <http://labor.state.ak.us/lss/pamp600.htm>

For questions regarding prevailing wage or employment preference requirements, please contact the nearest Wage and Hour office. These offices are listed on Page x.

Sincerely,

A handwritten signature in black ink that reads "Tamika L. Ledbetter".

Dr. Tamika L. Ledbetter  
Commissioner

- This page intentionally left blank -

# Table of Contents

## Excerpts from Alaska Law

Sec. 36.05.005. Applicability.....	iv
Sec. 36.05.010. Wage rates on public construction. ....	iv
Sec. 36.05.040. Filing schedule of employees, wages paid and other information .....	iv
Sec. 36.05.045. Notice of work and completion; withholding of payment .....	iv
Sec. 36.05.060. Penalty for violation of this chapter .....	v
Sec. 36.05.070. Wage rates in specifications and contracts for public works .....	v
Sec. 36.05.080. Failure to pay agreed wages.....	v
Sec. 36.05.090. Payment of wages from withheld payments and listing contractors who violate contracts .....	v
Sec. 36.05.900. Definition.. ..	vi

## Excerpts from Alaska Administrative Code

8 AAC 30.051. Purpose .....	vi
8 AAC 30.052. Board and lodging; remote sites .....	vi
8 AAC 30.054. Per diem instead of board and lodging .....	vi
8 AAC 30.056. Alternative arrangement .....	vii
8 AAC 30.900. General definitions (selected excerpts).....	vii

## Additional Information

Per Diem .....	vii
Laborer Classification Clarification.....	viii
Apprentice Rates.....	viii
Fringe Benefit Plans.....	viii
Special Prevailing Wage Rate Determination.....	ix
Alaska Employment Preference Information.....	ix
Labor Standards and Safety Notice Requests .....	x
Debarment List .....	x

## Wage Rates ..... Pages 1-26

**Note to Readers:** The statutes and administrative regulations listed in this publication were taken from the official codes, as of the effective date of the publication. However, there may be errors or omissions that have not been identified and changes that occurred after the publication was printed. This publication is intended as an informational guide only and is not intended to serve as a precise statement of the statutes and regulations of the State of Alaska. To be certain of current laws and regulations, please refer to the official codes.

## EXCERPTS FROM ALASKA LAW

### **Sec. 36.05.005. Applicability.**

This chapter applies only to a public construction contract that exceeds \$25,000.

### **Sec. 36.05.010. Wage rates on public construction.**

A contractor or subcontractor who performs work on a public construction contract in the state shall pay not less than the current prevailing rate of wages for work of a similar nature in the region in which the work is done. The current prevailing rate of wages is that contained in the latest determination of prevailing rate of wages issued by the Department of Labor and Workforce Development at least 10 days before the final date for submission of bids for the contract. The rate shall remain in effect for the life of the contract or for 24 calendar months, whichever is shorter. At the end of the initial 24-month period, if new wage determinations have been issued by the department, the latest wage determination shall become effective for the next 24-month period or until the contract is completed, whichever occurs first. This process shall be repeated until the contract is completed.

### **Sec. 36.05.040. Filing schedule of employees, wages paid, and other information.**

All contractors or subcontractors who perform work on a public construction contract for the state or for a political subdivision of the state shall, before the Friday of every second week, file with the Department of Labor and Workforce Development a sworn affidavit for the previous reporting period, setting out in detail the number of persons employed, wages paid, job classification of each employee, hours worked each day and week, and other information on a form provided by the Department of Labor and Workforce Development.

### **Sec. 36.05.045. Notice of work and completion; withholding of payment.**

- (a) Before commencing work on a public construction contract, the person entering into the contract with a contracting agency shall designate a primary contractor for purposes of this section. Before work commences, the primary contractor shall file a notice of work with the Department of Labor and Workforce Development. The notice of work must list work to be performed under the public construction contract by each contractor who will perform any portion of work on the contract and the contract price being paid to each contractor. The primary contractor shall pay all filing fees for each contractor performing work on the contract, including a filing fee based on the contract price being paid for work performed by the primary contractor's employees. The filing fee payable shall be the sum of all fees calculated for each contractor. The filing fee shall be one percent of each contractor's contract price. The total filing fee payable by the primary contractor under this subsection may not exceed \$5,000. In this subsection, "contractor" means an employer who is using employees to perform work on the public construction contract under the contract or a subcontract.
- (b) Upon completion of all work on the public construction contract, the primary contractor shall file with the Department of Labor and Workforce Development a notice of completion together with payment of any additional filing fees owed due to increased contract amounts. Within 30 days after the department's receipt of the primary contractor's notice of completion, the department shall inform the contracting agency of the amount, if any, to be withheld from the final payment.
- (c) A contracting agency
  - (1) may release final payment of a public construction contract to the extent that the agency has received verification from the Department of Labor and Workforce Development that
    - (A) the primary contractor has complied with (a) and (b) of this section;
    - (B) the Department of Labor and Workforce Development is not conducting an investigation under this title; and
    - (C) the Department of Labor and Workforce Development has not issued a notice of a violation of this chapter to the primary contractor or any other contractors working on the public construction contract; and

- (2) shall withhold from the final payment an amount sufficient to pay the department's estimate of what may be needed to compensate the employees of any contractors under investigation on this construction contract, and any unpaid filing fees.
- (d) The notice and filing fee required under (a) of this section may be filed after work has begun if
  - (1) The public construction contract is for work undertaken in immediate response to an emergency; and
  - (2) The notice and fees are filed not later than 14 days after the work has begun.
- (e) A false statement made on a notice required by this section is punishable under AS 11.56.210.

**Sec. 36.05.060. Penalty for violation of this chapter.**

A contractor who violates this chapter is guilty of a misdemeanor and upon conviction is punishable by a fine of not less than \$100 nor more than \$1,000, or by imprisonment for not less than 10 days nor more than 90 days, or by both. Each day a violation exists constitutes a separate offense.

**Sec. 36.05.070. Wage rates in specifications and contracts for public works.**

- (a) The advertised specifications for a public construction contract that requires or involves the employment of mechanics, laborers, or field surveyors must contain a provision stating the minimum wages to be paid various classes of laborers, mechanics, or field surveyors and that the rate of wages shall be adjusted to the wage rate under AS 36.05.010.
- (b) Repealed by §17 ch 142 SLA 1972.
- (c) A public construction contract under (a) of this section must contain provisions that
  - (1) the contractor or subcontractors of the contractor shall pay all employees unconditionally and not less than once a week;
  - (2) wages may not be less than those stated in the advertised specifications, regardless of the contractual relationship between the contractor or subcontractors and laborers, mechanics, or field surveyors;
  - (3) the scale of wages to be paid shall be posted by the contractor in a prominent and easily accessible place at the site of the work;
  - (4) the state or a political subdivision shall withhold so much of the accrued payments as is necessary to pay to laborers, mechanics, or field surveyors employed by the contractor or subcontractors the difference between
    - (A) the rates of wages required by the contract to be paid laborers, mechanics, or field surveyors on the work; and
    - (B) the rates of wages in fact received by laborers, mechanics, or field surveyors.

**Sec. 36.05.080. Failure to pay agreed wages.**

Every contract within the scope of AS 36.05.070 shall contain a provision that if it is found that a laborer, mechanic, or field surveyor employed by the contractor or subcontractor has been or is being paid a rate of wages less than the rate of wages required by the contract to be paid, the state or its political subdivision may, by written notice to the contractor, terminate the contractor's right to proceed with the work or the part of the work for which there is a failure to pay the required wages and to prosecute the work to completion by contract or otherwise, and the contractor and the contractor's sureties are liable to the state or its political subdivision for excess costs for completing the work.

**Sec. 36.05.090. Payment of wages from withheld payments and listing contractors who violate contracts.**

- (a) The state disbursing officer in the case of a state public construction contract and the local fiscal officer in the case of a political subdivision public construction contract shall pay directly to laborers, mechanics, or field surveyors from accrued payments withheld under the terms of the contract the wages due laborers, mechanics, or field surveyors under AS 36.05.070.
- (b) The state disbursing officer or the local fiscal officer shall distribute to all departments of the state government and to all political subdivisions of the state a list giving the names of persons who have disregarded their obligations to employees. A person appearing on this list and a firm, corporation, partnership, or association in which the person has an interest may not work as a contractor or

subcontractor on a public construction contract for the state or a political subdivision of the state until three years after the date of publication of the list. If the accrued payments withheld under the contract are insufficient to reimburse all the laborers, mechanics, or field surveyors with respect to whom there has been a failure to pay the wages required under AS 36.05.070, the laborers, mechanics, or field surveyors have the right of action or intervention or both against the contractor and the contractor's sureties conferred by law upon persons furnishing labor or materials, and in the proceedings it is not a defense that the laborers, mechanics, or field surveyors accepted or agreed to accept less than the required rate of wages or voluntarily made refunds.

**Sec. 36.05.900. Definition.**

In this chapter, "contracting agency" means the state or a political subdivision of the state that has entered into a public construction contract with a contractor.

**EXCERPTS FROM ALASKA ADMINISTRATIVE CODE**

\*\*\***Notice:** Regulations relating to board and lodging and per diem went into effect on November 25, 2018. The new regulations are excerpted here\*\*\*

**8 AAC 30.051. Purpose.** The purpose of 8 AAC 30.052 – 8 AAC 30.056 is to ensure that wages paid to laborers, mechanics, and field surveyors do not fall below the prevailing rate of pay.

**8 AAC 30.052. Board and lodging; remote sites.** (a) A contractor on a public construction project located 65 or more road miles from the international airport closest to the project area in either Fairbanks, Juneau, or Anchorage, or that is inaccessible by road in a two-wheel drive vehicle, shall provide adequate board and lodging to each laborer, mechanic, or field surveyor while the person is employed on the project. If commercial lodging facilities are not available, the contractor shall provide temporary lodging facilities. Lodging facilities must comply with all applicable state and federal laws. For a highway project, the location of the project is measured from the midpoint of the project.

(b) A contractor is not required to provide board and lodging:

(1) to a laborer, mechanic, or field surveyor who is a domiciled resident of the project area; or

(2) on a laborer, mechanic, or field surveyor's scheduled days off, when the person can reasonably travel between the project and the person's permanent residence; for the purposes of this paragraph, "scheduled day off" means a day in which a person does not perform work on-site, is not required to remain at or near the job location for the benefit of the contractor, and is informed of the day off at least seven days before the day off.

(c) Upon a contractor's written request, the commissioner may waive the requirements of (a) of this section where:

(1) the project is inaccessible by road in a two-wheel drive vehicle, but the laborer, mechanic, or field surveyor can reasonably travel between the project and the person's permanent residence within one hour; or

(2) a laborer, mechanic, or field surveyor is not a domiciled resident of the project area, but has established permanent residence, with the intent to remain indefinitely, within 65 road miles of the project, or for a highway project, the mid-point of the project.

**8 AAC 30.054. Per diem instead of board and lodging.** (a) A contractor may pay a laborer, mechanic, or field surveyor per diem instead of providing board and lodging, when the following conditions are met:

(1) the department determines that per diem instead of board and lodging is an established practice for the work classification; the department shall publish and periodically revise its determinations in the pamphlet *Laborers' and Mechanics' Minimum Rates of Pay*;

(2) the contractor pays each laborer, mechanic, or field surveyor the appropriate per diem rate as published and periodically revised in the pamphlet *Laborers' and Mechanics' Minimum Rates of Pay*; and

(3) the contractor pays the per diem to each laborer, mechanic, or field surveyor on the same day that wages are paid.

(b) A contractor may not pay per diem instead of board and lodging on a highway project located

- (1) west of Livengood on the Elliot Highway, AK-2;
- (2) on the Dalton Highway, AK-11;
- (3) north of milepost 20 on the Taylor Highway, AK-5;
- (4) east of Chicken on the Top of the World Highway; or
- (5) south of Tetlin Junction to the Alaska-Canada border on the Alaska Highway, AK-2.

**8 AAC 30.056. Alternative arrangement.** Upon a contractor’s written request, the commissioner may approve an alternative board and lodging or per diem arrangement, provided

- (1) the arrangement does not reduce the laborer, mechanic, or field surveyor’s wages below the prevailing wage rate; and
- (2) the laborer, mechanic, or field surveyor voluntarily enters into and signs the written arrangement; a labor organization representing laborers, mechanics, or field surveyors may enter into the written agreement on their behalf.

**8 AAC 30.900. General definitions** (selected excerpts only):

In this chapter and in AS 36

- (22) “domiciled resident” means a person living within 65 road miles of a public construction project, or in the case of a highway project, the mid-point of the project, for at least 12 consecutive months prior to the award of the public construction project;
- (23) “employed on the project” means the time period from the date the laborer, mechanic, or field surveyor first reports on-site to the project through the final date the person reports on-site to the project.

## **ADDITIONAL INFORMATION**

### **PER DIEM**

**Notice:** New regulations relating to board and lodging and per diem went into effect on November 25, 2018. The regulations provide a comprehensive set of requirements for the provision of board and lodging or per diem for workers on remote projects. Please refer to Alaska Administrative Code 8 AAC Chapter 30 and read the chapter carefully.

The Alaska Department of Labor and Workforce Development has determined that per diem is an established work practice for certain work classifications. These classifications are indicated throughout the Pamphlet by an asterisk (\*) under the classification title. If all of the conditions of 8 AAC 30.054 are met, an employer may pay workers in these classifications per diem instead of providing board and lodging on a remote project.

**Per Diem Rate:** As of May 1<sup>st</sup>, 2019, the minimum per diem rate is \$100.00 per day, or part thereof, the worker is employed on the project. In the event that a contractor provides lodging facilities, but no meals, the department will accept a payment of \$48 per day for meals to meet the per diem requirements.



**LABORER CLASSIFICATION CLARIFICATION**

The laborer rates categorized in class code S1201-S1206 apply in one area of Alaska; the area that is south of N63 latitude and west of W138 Longitude. The laborer rates categorized in class code N1201-N1206 apply in two areas of Alaska; the Alaska areas north of N63 latitude and east of W138 longitude. The following graphic representations should assist with clarifying the applicable wage rate categories:

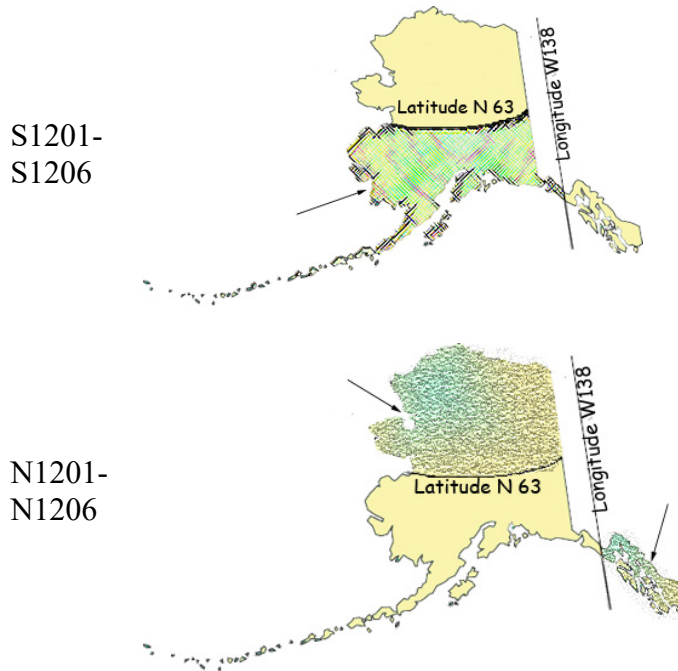

**APPRENTICE RATES**

Apprentice rates at less than the minimum prevailing rates may be paid to apprentices according to an apprentice program which has been registered and approved by the Commissioner of the Alaska Department of Labor and Workforce Development in writing or according to a bona fide apprenticeship program registered with the U.S. Department of Labor, Office of Apprenticeship Training. **Any employee listed on a payroll at an apprentice wage rate who is not registered as above shall be paid the journeyman prevailing minimum wage in that work classification.** Wage rates are based on prevailing crew makeup practices in Alaska and apply to work performed regardless of either the quality of the work performed by the employee or the titles or classifications which may be assigned to individual employees.

**FRINGE BENEFIT PLANS**

Contractors/subcontractors may compensate fringe benefits to their employees in any one of three methods. The fringe benefits may be paid into a union trust fund, into an approved benefit plan, or paid directly on the paycheck as gross wages.

Where fringe benefits are paid into approved plans, funds, or programs including union trust funds, the payments must be contributed at least monthly. If contractors submit their own payroll forms and are paying fringe benefits into approved plans, funds, or programs, the employer’s certification must include, in addition to those requirements of 8 AAC 30.020(c), a statement that fringe benefit payments have been or will be paid at least monthly. Contractors who pay fringe benefits to a plan must ensure the plan is one approved by the Internal Revenue Service and that the plan meets the requirements of 8 AAC 30.025 (eff. 3/2/08) in order for payments to be credited toward the prevailing wage obligation.

**SPECIAL PREVAILING WAGE RATE DETERMINATION**

Special prevailing wage rate determinations may be requested for special projects or a special worker classification if the work to be performed does not conform to traditional public construction for which a prevailing wage rate has been established under 8 AAC 30.050(a) of this section. Requests for special wage rate determinations must be in writing and filed with the Commissioner at least 30 days before the award of the contract. An applicant for a special wage rate determination shall have the responsibility to support the necessity for the special rate. An application for a special wage rate determination filed under this section must contain:

- (1) a specification of the contract or project on which the special rates will apply and a description of the work to be performed;
- (2) a brief narrative explaining why special wage rates are necessary;
- (3) the job class or classes involved;
- (4) the special wage rates the applicant is requesting, including survey or other relevant wage data to support the requested rates;
- (5) the approximate number of employees who would be affected; and
- (6) any other information which might be helpful in determining if special wage rates are appropriate.

Requests made pursuant to the above should be addressed to:

Director  
Alaska Department of Labor and Workforce Development  
Labor Standards and Safety Division  
Wage and Hour Administration  
P.O. Box 111149  
Juneau, AK 99811-1149

-or-

Email: [statewide.wagehour@alaska.gov](mailto:statewide.wagehour@alaska.gov)

**EMPLOYMENT PREFERENCE INFORMATION**

In October 2019, the Alaska Attorney General issued a formal opinion stating that the Alaska Statutes 36.10.150 of the State’s 90% Employment Preference law, also known as the Alaska Resident Hire law, violates both the U.S. and Alaska Constitutions. As a result, the state has stopped all enforcement activity.

A copy of the Attorney General opinion is found here:

[http://law.alaska.gov/pdf/opinions/opinions\\_2019/19-005\\_AK-hire.pdf](http://law.alaska.gov/pdf/opinions/opinions_2019/19-005_AK-hire.pdf)

**Alaska Department of Labor and Workforce Development  
Labor Standards and Safety Division  
Wage and Hour Administration  
Web site: <http://labor.state.ak.us/lss/pamp600.htm>**

**Anchorage**

1251 Muldoon Road, Suite 113  
Anchorage, Alaska 99504-2098  
Phone: (907) 269-4900

Email:  
statewide.wagehour@alaska.gov

**Juneau**

PO Box 111149  
Juneau, Alaska 99811  
Phone: (907) 465-4842

Email:  
statewide.wagehour@alaska.gov

**Fairbanks**

Regional State Office Building  
675 7<sup>th</sup> Ave., Station J-1  
Fairbanks, Alaska 99701-4593  
Phone: (907) 451-2886

Email:  
statewide.wagehour@alaska.gov

**LABOR STANDARDS AND SAFETY NOTICE REQUESTS**

If you would like to receive Wage and Hour Administration or Mechanical Inspection **regulation notices** or **publications information**, they are available via electronic mail, by signing up in the GovDelivery System, <https://public.govdelivery.com/accounts/AKDOL/subscriber/new> and selecting topics *LSS – Wage and Hour – Forms and Publications*, *LSS – Mechanical Inspection Regulations*, or *LSS – Wage and Hour Regulations*.

*Publications* are also available online at <http://labor.alaska.gov/lss/home.htm>

**DEBARMENT LIST**

**AS 36.05.090(b)** states that “the state disbursing officer or the local fiscal officer shall distribute to all departments of the state government and to all political subdivisions of the state a list giving the names of persons who have disregarded their obligations to employees.”

A person appearing on the following debarment list and a firm, corporation, partnership, or association in which the person has an interest may not work as a contractor or subcontractor on a public construction contract for the state or a political subdivision of the state for three years from the date of debarment.

Company Name

Debarment Expires

No companies are currently debarred.

# Laborers' & Mechanics' Minimum Rates of Pay

Class Code	Classification of Laborers & Mechanics	BHR	H&W	PEN	TRN	Other	Benefits	THR
------------	--	-----	-----	-----	-----	-------	----------	-----

## Boilermakers

\*See per diem note on last page

<b>A0101</b>	Boilermaker (journeyman)	47.03	8.57	17.02	1.90	VAC	SAF	78.36
						3.50	0.34	

## Bricklayers & Blocklayers

\*See per diem note on last page

<b>A0201</b>	Blocklayer	42.16	9.00	10.05	0.62	L&M		62.03
						0.20		

Bricklayer  
 Marble or Stone Mason  
 Refractory Worker (Firebrick, Plastic, Castable, and Gunitite Refractory Applications)  
 Terrazzo Worker  
 Tile Setter

<b>A0202</b>	Tuck Pointer Caulker	42.16	9.00	10.05	0.62	L&M		62.03
						0.20		

Cleaner (PCC)

<b>A0203</b>	Marble & Tile Finisher	35.99	9.00	10.05	0.62	L&M		55.86
						0.20		

Terrazzo Finisher

<b>A0204</b>	Torginal Applicator	40.10	9.83	8.50	0.55	L&M	0.87	60.00
						0.15		

## Carpenters, Region I (North of 63 latitude)

\*See per diem note on last page

<b>N0301</b>	Carpenter (journeyman)	38.34	10.08	15.23	1.10	L&M	SAF	64.95
						0.10	0.10	

Lather/Drywall/Acoustical

## Carpenters, Region II (South of N63 latitude)

\*See per diem note on last page

<b>S0301</b>	Carpenter (journeyman)	38.34	10.08	15.77	1.10	L&M	SAF	65.49
						0.10	0.10	

Lather/Drywall/Acoustical

## Cement Masons

\*See per diem note on last page

Wage benefits key: BHR=basic hourly rate; H&W=health and welfare; IAF=industry advancement fund; LEG=legal fund; L&M=labor/management fund; PEN=pens fund; SAF=safety; SUI=supplemental unemployment insurance; S&L=SUI & LEG combined; TRN=training; THR=total hourly rate; VAC=vacation

<b>Cement Masons</b>								
*See per diem note on last page								

<b>A0401</b>	Group I, including:	39.38	8.70	11.80	1.43		<b>L&amp;M</b> 0.10	61.41
--------------	---------------------	-------	------	-------	------	--	------------------------	-------

- Application of Sealing Compound
- Application of Underlayment
- Building, General
- Cement Finisher
- Cement Mason (journeyman)
- Concrete
- Concrete Paving
- Concrete Polishing
- Concrete Repair
- Curb & Gutter, Sidewalk
- Curing of All Concrete
- General Concrete Pour Tender
- Grouting & Caulking of Tilt-Up Panels
- Grouting of All Plates
- Patching Concrete
- Screed Pin Setter
- Screeder or Rodder
- Spackling/Skim Coating

<b>A0402</b>	Group II, including:	39.38	8.70	11.80	1.43		<b>L&amp;M</b> 0.10	61.41
--------------	----------------------	-------	------	-------	------	--	------------------------	-------

- Form Setter

<b>A0403</b>	Group III, including:	39.38	8.70	11.80	1.43		<b>L&amp;M</b> 0.10	61.41
--------------	-----------------------	-------	------	-------	------	--	------------------------	-------

- Concrete Saw Cutter Operator (All Control Joints and Self-powered)
- Curb & Gutter Machine
- Floor Grinder
- Pneumatic Power Tools
- Power Chipping & Bushing
- Sand Blasting Architectural Finish
- Screed & Rodding Machine Operator
- Troweling Machine Operator (all concrete surfaces)

<b>A0404</b>	Group IV, including:	39.38	8.70	11.80	1.43		<b>L&amp;M</b> 0.10	61.41
--------------	----------------------	-------	------	-------	------	--	------------------------	-------

- Acoustical or Imitation Acoustical Finish
- Application of All Composition Mastic
- Application of All Epoxy Material
- Application of All Plastic Material
- Finish Colored Concrete
- Guniting Nozzleman

Wage benefits key: BHR=basic hourly rate; H&W=health and welfare; IAF=industry advancement fund; LEG=legal fund; L&M=labor/management fund; PEN=pens fund; SAF=safety; SUI=supplemental unemployment insurance; S&L=SUI & LEG combined; TRN=training; THR=total hourly rate; VAC=vacation

**Cement Masons**  
 \*See per diem note on last page

<b>A0404</b>	Group IV, including:	39.38	8.70	11.80	1.43		<b>L&amp;M</b> 0.10	61.41
	Hand Powered Grinder							
	Preparing, scratching and browsing of all ceilings and walls, finished with terrazo or tile							
	Tunnel Worker							

<b>A0405</b>	Group V, including:	39.38	8.70	11.80	1.43		<b>L&amp;M</b> 0.10	61.41
	Casting and finishing							
	EIFS Systems							
	Finishing of all interior and exterior plastering							
	Fireproofing (Pryocrete, Cafco, Albi-Clad, sprayed fiberglass)							
	Gypsum, Portland Cement							
	Kindred material and products							
	Operation and control of all types of plastering machines, including power tools and floats, used by the industry							
	Overcoating and maintenance of interior/exterior plaster surfaces							
	Plasterer							
	Veneer plastering process (Rapid Plaster, U.S.G. "Imperial Systems", and Pabcoat Systems")							
	Venetian plaster and color-integrated Italian/Middle-Eastern line plaster							

**Culinary Workers**

<b>A0501</b>	Baker/Cook	28.37	7.31	7.56			<b>LEG</b>	43.24
<b>A0503</b>	General Helper	25.07	7.31	7.56			<b>LEG</b>	39.94
	Housekeeper							
	Janitor							
	Kitchen Helper							
<b>A0504</b>	Head Cook	28.97	7.31	7.56			<b>LEG</b>	43.84
<b>A0505</b>	Head Housekeeper	25.45	7.31	7.56			<b>LEG</b>	40.32
	Head Kitchen Help							

**Dredgemen**  
 \*See per diem note on last page

Wage benefits key: BHR=basic hourly rate; H&W=health and welfare; IAF=industry advancement fund; LEG=legal fund; L&M=labor/management fund; PEN=pens fund; SAF=safety; SUI=supplemental unemployment insurance; S&L=SUI & LEG combined; TRN=training; THR=total hourly rate; VAC=vacation

Class Code	Classification of Laborers & Mechanics	BHR	H&W	PEN	TRN	Other	Benefits	THR
------------	--	-----	-----	-----	-----	-------	----------	-----

**Dredgemen**  
\*See per diem note on last page

<b>A0601</b>	Assistant Engineer	41.76	10.70	13.50	1.00	<b>L&amp;M</b>		67.11
	Craneman					0.10	0.05	
	Electrical Generator Operator (primary pump/power barge/dredge)							
	Engineer							
	Welder							
<b>A0602</b>	Assistant Mate (deckhand)	40.60	10.70	13.50	1.00	<b>L&amp;M</b>		65.95
						0.10	0.05	
<b>A0603</b>	Fireman	41.04	10.70	13.50	1.00	<b>L&amp;M</b>		66.39
						0.10	0.05	
<b>A0605</b>	Leverman Clamshell	44.29	10.70	13.50	1.00	<b>L&amp;M</b>		69.64
						0.10	0.05	
<b>A0606</b>	Leverman Hydraulic	42.53	10.70	13.50	1.00	<b>L&amp;M</b>		67.88
						0.10	0.05	
<b>A0607</b>	Mate & Boatman	41.76	10.70	13.50	1.00	<b>L&amp;M</b>		67.11
						0.10	0.05	
<b>A0608</b>	Oiler (dredge)	41.04	10.70	13.50	1.00	<b>L&amp;M</b>		66.39
						0.10	0.05	

**Electricians**  
\*See per diem note on last page

<b>A0701</b>	Inside Cable Splicer	42.02	14.05	13.90	0.95	<b>L&amp;M</b>		<b>LEG</b>	71.27
						0.20	0.15		
<b>A0702</b>	Inside Journeyman Wireman, including:	41.69	14.05	14.14	0.95	<b>L&amp;M</b>		<b>LEG</b>	71.18
	Technicians (including use of drones in electrical construction)					0.20	0.15		
<b>A0703</b>	Power Cable Splicer	60.79	14.05	19.01	0.95	<b>L&amp;M</b>		<b>LEG</b>	95.20
						0.25	0.15		
<b>A0704</b>	Tele Com Cable Splicer	50.53	14.05	16.67	0.95	<b>L&amp;M</b>		<b>LEG</b>	82.55
						0.20	0.15		
<b>A0705</b>	Power Journeyman Lineman, including:	59.04	14.05	18.96	0.95	<b>L&amp;M</b>		<b>LEG</b>	93.40
	Power Equipment Operator								
	Technician (including use of drones in electrical construction)								
<b>A0706</b>	Tele Com Journeyman Lineman, including:	48.78	14.05	16.61	0.95	<b>L&amp;M</b>		<b>LEG</b>	80.74
	Technician (including use of drones in telecommunications construction)					0.20	0.15		
	Tele Com Equipment Operator								

Wage benefits key: BHR=basic hourly rate; H&W=health and welfare; IAF=industry advancement fund; LEG=legal fund; L&M=labor/management fund; PEN=pens fund; SAF=safety; SUI=supplemental unemployment insurance; S&L=SUI & LEG combined; TRN=training; THR=total hourly rate; VAC=vacation

Class Code	Classification of Laborers & Mechanics	BHR	H&W	PEN	TRN	Other	Benefits	THR
------------	--	-----	-----	-----	-----	-------	----------	-----

**Electricians**  
\*See per diem note on last page

<b>A0707</b>	Straight Line Installer - Repairman	48.78	14.05	16.61	0.95	L&M	LEG	80.74
						0.20	0.15	
<b>A0708</b>	Powderman	57.04	14.05	18.90	0.95	L&M	LEG	91.34
						0.25	0.15	
<b>A0710</b>	Material Handler	26.57	13.76	5.30	0.15	L&M	LEG	46.08
						0.15	0.15	
<b>A0712</b>	Tree Trimmer Groundman	28.37	14.05	12.59	0.15	L&M	LEG	55.46
						0.15	0.15	
<b>A0713</b>	Journeyman Tree Trimmer	37.30	14.05	12.86	0.15	L&M	LEG	64.66
						0.15	0.15	
<b>A0714</b>	Vegetation Control Sprayer	40.85	14.05	12.97	0.15	L&M	LEG	68.32
						0.15	0.15	
<b>A0715</b>	Inside Journeyman Communications CO/PBX	40.27	14.05	13.85	0.95	L&M	LEG	69.47
						0.20	0.15	

**Elevator Workers**  
\*See per diem note on last page

<b>A0802</b>	Elevator Constructor	42.76	15.88	19.31	0.64	L&M	VAC	83.87
						0.54	4.74	
<b>A0803</b>	Elevator Constructor Mechanic	61.08	15.88	19.31	0.64	L&M	VAC	104.23
						0.54	6.78	

**Heat & Frost Insulators/Asbestos Workers**  
\*See per diem note on last page

<b>A0902</b>	Asbestos Abatement-Mechanical Systems	38.68	9.24	11.01	1.20	SAF		60.25
						0.12		
<b>A0903</b>	Asbestos Abatement/General Demolition All Systems	38.68	9.24	11.01	1.20	SAF		60.25
						0.12		
<b>A0904</b>	Insulator, Group II	38.68	9.24	11.01	1.20	SAF		60.25
						0.12		
<b>A0905</b>	Fire Stop	38.68	9.24	11.01	1.20	SAF		60.25
						0.12		

**IronWorkers**  
\*See per diem note on last page

<b>A1101</b>	Ironworkers, including:	38.87	9.51	24.28	0.74	L&M	IAF	73.84
						0.20	0.24	

Wage benefits key: BHR=basic hourly rate; H&W=health and welfare; IAF=industry advancement fund; LEG=legal fund; L&M=labor/management fund; PEN=pens fund; SAF=safety; SUI=supplemental unemployment insurance; S&L=SUI & LEG combined; TRN=training; THR=total hourly rate; VAC=vacation



**IronWorkers**  
 \*See per diem note on last page

						L&M	IAF	
<b>A1101</b>	Ironworkers, including:	38.87	9.51	24.28	0.74	0.20	0.24	73.84
	Bender Operators							
	Bridge & Structural							
	Hangar Doors							
	Hollow Metal Doors							
	Industrial Doors							
	Machinery Mover							
	Ornamental							
	Reinforcing							
	Rigger							
	Sheeter							
	Signalman							
	Stage Rigger							
	Toxic Haz-Mat Work							
	Welder							

						L&M	IAF	
<b>A1102</b>	Helicopter	39.87	9.51	24.28	0.74	0.20	0.24	74.84
	Helicopter (used for rigging and setting)							
	Tower (energy producing windmill type towers to include nacelle and blades)							

						L&M	IAF	
<b>A1103</b>	Fence/Barrier Installer	35.37	9.51	23.93	0.74	0.20	0.24	69.99

						L&M	IAF	
<b>A1104</b>	Guard Rail Layout Man	36.11	9.51	23.93	0.74	0.20	0.24	70.73

						L&M	IAF	
<b>A1105</b>	Guard Rail Installer	36.37	9.51	23.93	0.74	0.20	0.24	70.99

**Laborers (The Alaska areas north of N63 latitude and east of W138 longitude)**  
 \*See per diem note on last page

						L&M	LEG	
<b>N1201</b>	Group I, including:	32.00	8.95	20.66	1.30	0.20	0.20	63.31
	Asphalt Worker (shovelman, plant crew)							
	Brush Cutter							
	Camp Maintenance Laborer							
	Carpenter Tender or Helper							
	Choke Setter, Hook Tender, Rigger, Signalman							
	Concrete Labor (curb & gutter, chute handler, curing, grouting, screeding)							
	Crusher Plant Laborer							
	Demolition Laborer							

Wage benefits key: BHR=basic hourly rate; H&W=health and welfare; IAF=industry advancement fund; LEG=legal fund; L&M=labor/management fund; PEN=pens fund; SAF=safety; SUI=supplemental unemployment insurance; S&L=SUI & LEG combined; TRN=training; THR=total hourly rate; VAC=vacation

**Laborers (The Alaska areas north of N63 latitude and east of W138 longitude)**

\*See per diem note on last page

						L&M	LEG	
<b>N1201</b>	Group I, including:	32.00	8.95	20.66	1.30	0.20	0.20	63.31
	Ditch Digger							
	Dumpman							
	Environmental Laborer (hazard/toxic waste, oil spill)							
	Fence Installer							
	Fire Watch Laborer							
	Flagman							
	Form Stripper							
	General Laborer							
	Guardrail Laborer, Bridge Rail Installer							
	Hydro-seeder Nozzleman							
	Laborer, Building							
	Landscaper or Planter							
	Laying of Mortarless Decorative Block (retaining walls, flowered decorative block 4 feet or less - highway or landscape work)							
	Material Handler							
	Pneumatic or Power Tools							
	Portable or Chemical Toilet Serviceman							
	Pump Man or Mixer Man							
	Railroad Track Laborer							
	Sandblast, Pot Tender							
	Saw Tender							
	Slurry Work							
	Steam Cleaner Operator							
	Steam Point or Water Jet Operator							
	Storm Water Pollution Protection Plan Worker (SWPPP Worker - erosion and sediment control Laborer)							
	Tank Cleaning							
	Utiliwalk & Utilidor Laborer							
	Watchman (construction projects)							
	Window Cleaner							

						L&M	LEG	
<b>N1202</b>	Group II, including:	33.00	8.95	20.66	1.30	0.20	0.20	64.31
	Burning & Cutting Torch							
	Cement or Lime Dumper or Handler (sack or bulk)							
	Certified Erosion Sediment Control Lead (CESCL Laborer)							
	Choker Splicer							
	Chucktender (wagon, air-track & hydraulic drills)							
	Concrete Laborer (power buggy, concrete saws, pumpcrete nozzleman, vibratorman)							
	Culvert Pipe Laborer							

Wage benefits key: BHR=basic hourly rate; H&W=health and welfare; IAF=industry advancement fund; LEG=legal fund; L&M=labor/management fund; PEN=pens fund; SAF=safety; SUI=supplemental unemployment insurance; S&L=SUI & LEG combined; TRN=training; THR=total hourly rate; VAC=vacation

**Laborers (The Alaska areas north of N63 latitude and east of W138 longitude)**

\*See per diem note on last page

<b>N1202</b>	Group II, including:	33.00	8.95	20.66	1.30	<b>L&amp;M</b>	<b>LEG</b>	64.31
--------------	----------------------	-------	------	-------	------	----------------	------------	-------

- Cured Inplace Pipelayer
- Environmental Laborer (asbestos, marine work)
- Floor Preparation, Core Drilling
- Foam Gun or Foam Machine Operator
- Green Cutter (dam work)
- Gunite Operator
- Hod Carrier
- Jackhammer/Chipping Gun or Pavement Breaker
- Laser Instrument Operator
- Laying of Mortarless Decorative Block (retaining walls, flowered decorative block over 4 feet - highway or landscape work)
- Mason Tender & Mud Mixer (sewer work)
- Pilot Car
- Pipelayer Helper
- Plasterer, Bricklayer & Cement Finisher Tender
- Powderman Helper
- Power Saw Operator
- Railroad Switch Layout Laborer
- Sandblaster
- Scaffold Building & Erecting
- Sewer Caulker
- Sewer Plant Maintenance Man
- Thermal Plastic Applicator
- Timber Faller, Chainsaw Operator, Filer
- Timberman

<b>N1203</b>	Group III, including:	33.90	8.95	20.66	1.30	<b>L&amp;M</b>	<b>LEG</b>	65.21
--------------	-----------------------	-------	------	-------	------	----------------	------------	-------

- Bit Grinder
- Camera/Tool/Video Operator
- Guardrail Machine Operator
- High Rigger & Tree Topper
- High Scaler
- Multiplate
- Plastic Welding
- Slurry Seal Squeegee Man
- Traffic Control Supervisor
- Welding Certified (in connection with laborer's work)

<b>N1204</b>	Group IIIA	37.18	8.95	20.66	1.30	<b>L&amp;M</b>	<b>LEG</b>	68.49
--------------	------------	-------	------	-------	------	----------------	------------	-------

- Asphalt Raker, Asphalt Belly Dump Lay Down

Wage benefits key: BHR=basic hourly rate; H&W=health and welfare; IAF=industry advancement fund; LEG=legal fund; L&M=labor/management fund; PEN=pens fund; SAF=safety; SUI=supplemental unemployment insurance; S&L=SUI & LEG combined; TRN=training; THR=total hourly rate; VAC=vacation

**Laborers (The Alaska areas north of N63 latitude and east of W138 longitude)**

\*See per diem note on last page

						L&M	LEG	
<b>N1204</b>	Group IIIA	37.18	8.95	20.66	1.30	0.20	0.20	68.49
	Drill Doctor (in the field)							
	Driller (including, but not limited to wagon drills, air-track drills, hydraulic drills)							
	Pioneer Drilling & Drilling Off Tugger (all type drills)							
	Pipelayers							
	Powderman (Employee Possessor)							
	Storm Water Pollution Protection Plan Specialist (SWPPP Specialist)							
	Traffic Control Supervisor, DOT Qualified							

						L&M	LEG	
<b>N1205</b>	Group IV	21.57	8.95	20.66	1.30	0.20	0.20	52.88
	Final Building Cleanup							
	Permanent Yard Worker							

						L&M	LEG	
<b>N1206</b>	Group IIIB	40.97	6.24	20.66	1.30	0.20	0.20	69.57
	Driller (including, but not limited to wagon drills, air-track drills, hydraulic drills)(over 5,000 hours)							
	Federal Powderman (Responsible Person in Charge)							
	Grade Checking (setting or transferring of grade marks, line and grade, GPS, drones)							
	Pioneer Drilling & Drilling Off Tugger (all type drills)(over 5,000 hours)							
	Stake Hopper							

**Laborers (The area that is south of N63 latitude and west of W138 longitude)**

\*See per diem note on last page

						L&M	LEG	
<b>S1201</b>	Group I, including:	32.00	8.95	20.66	1.30	0.20	0.20	63.31
	Asphalt Worker (shovelman, plant crew)							
	Brush Cutter							
	Camp Maintenance Laborer							
	Carpenter Tender or Helper							
	Choke Setter, Hook Tender, Rigger, Signalman							
	Concrete Labor (curb & gutter, chute handler, curing, grouting, screeding)							
	Crusher Plant Laborer							
	Demolition Laborer							
	Ditch Digger							
	Dumpman							
	Environmental Laborer (hazard/toxic waste, oil spill)							
	Fence Installer							

Wage benefits key: BHR=basic hourly rate; H&W=health and welfare; IAF=industry advancement fund; LEG=legal fund; L&M=labor/management fund; PEN=pens fund; SAF=safety; SUI=supplemental unemployment insurance; S&L=SUI & LEG combined; TRN=training; THR=total hourly rate; VAC=vacation

**Laborers (The area that is south of N63 latitude and west of W138 longitude)**

\*See per diem note on last page

						L&M	LEG	
<b>S1201</b>	Group I, including:	32.00	8.95	20.66	1.30	0.20	0.20	63.31
	Fire Watch Laborer							
	Flagman							
	Form Stripper							
	General Laborer							
	Guardrail Laborer, Bridge Rail Installer							
	Hydro-seeder Nozzleman							
	Laborer, Building							
	Landscaper or Planter							
	Laying of Mortarless Decorative Block (retaining walls, flowered decorative block 4 feet or less - highway or landscape work)							
	Material Handler							
	Pneumatic or Power Tools							
	Portable or Chemical Toilet Serviceman							
	Pump Man or Mixer Man							
	Railroad Track Laborer							
	Sandblast, Pot Tender							
	Saw Tender							
	Slurry Work							
	Steam Cleaner Operator							
	Steam Point or Water Jet Operator							
	Storm Water Pollution Protection Plan Worker (SWPPP Worker - erosion and sediment control Laborer)							
	Tank Cleaning							
	Utiliwalk & Utilidor Laborer							
	Watchman (construction projects)							
	Window Cleaner							

						L&M	LEG	
<b>S1202</b>	Group II, including:	33.00	8.95	20.66	1.30	0.20	0.20	64.31
	Burning & Cutting Torch							
	Cement or Lime Dumper or Handler (sack or bulk)							
	Certified Erosion Sediment Control Lead (CESCL Laborer)							
	Choker Splicer							
	Chucktender (wagon, air-track & hydraulic drills)							
	Concrete Laborer (power buggy, concrete saws, pumpcrete nozzleman, vibratorman)							
	Culvert Pipe Laborer							
	Cured Inplace Pipelayer							
	Environmental Laborer (asbestos, marine work)							
	Floor Preparation, Core Drilling							
	Foam Gun or Foam Machine Operator							

Wage benefits key: BHR=basic hourly rate; H&W=health and welfare; IAF=industry advancement fund; LEG=legal fund; L&M=labor/management fund; PEN=pens fund; SAF=safety; SUI=supplemental unemployment insurance; S&L=SUI & LEG combined; TRN=training; THR=total hourly rate; VAC=vacation

**Laborers (The area that is south of N63 latitude and west of W138 longitude)**

\*See per diem note on last page

						L&M	LEG	
<b>S1202</b>	Group II, including:	33.00	8.95	20.66	1.30	0.20	0.20	64.31

- Green Cutter (dam work)
- Gunite Operator
- Hod Carrier
- Jackhammer/Chipping Gun or Pavement Breaker
- Laser Instrument Operator
- Laying of Mortarless Decorative Block (retaining walls, flowered decorative block over 4 feet - highway or landscape work)
- Mason Tender & Mud Mixer (sewer work)
- Pilot Car
- Pipelayer Helper
- Plasterer, Bricklayer & Cement Finisher Tender
- Powderman Helper
- Power Saw Operator
- Railroad Switch Layout Laborer
- Sandblaster
- Scaffold Building & Erecting
- Sewer Caulker
- Sewer Plant Maintenance Man
- Thermal Plastic Applicator
- Timber Faller, Chainsaw Operator, Filer
- Timberman

						L&M	LEG	
<b>S1203</b>	Group III, including:	33.90	8.95	20.66	1.30	0.20	0.20	65.21

- Bit Grinder
- Camera/Tool/Video Operator
- Guardrail Machine Operator
- High Rigger & Tree Topper
- High Scaler
- Multiplate
- Plastic Welding
- Slurry Seal Squeegee Man
- Traffic Control Supervisor
- Welding Certified (in connection with laborer's work)

						L&M	LEG	
<b>S1204</b>	Group IIIA	37.18	8.95	20.66	1.30	0.20	0.20	68.49

- Asphalt Raker, Asphalt Belly Dump Lay Down
- Drill Doctor (in the field)
- Driller (including, but not limited to wagon drills, air-track drills, hydraulic drills)
- Pioneer Drilling & Drilling Off Tugger (all type drills)

Wage benefits key: BHR=basic hourly rate; H&W=health and welfare; IAF=industry advancement fund; LEG=legal fund; L&M=labor/management fund; PEN=pens fund; SAF=safety; SUI=supplemental unemployment insurance; S&L=SUI & LEG combined; TRN=training; THR=total hourly rate; VAC=vacation

**Laborers (The area that is south of N63 latitude and west of W138 longitude)**

\*See per diem note on last page

<b>S1204</b>	Group IIIA	37.18	8.95	20.66	1.30	<b>L&amp;M</b>	<b>LEG</b>	68.49
--------------	------------	-------	------	-------	------	----------------	------------	-------

Pipelayers  
 Powderman (Employee Possessor)  
 Storm Water Pollution Protection Plan Specialist (SWPPP Specialist)  
 Traffic Control Supervisor, DOT Qualified

<b>S1205</b>	Group IV	21.57	8.95	20.66	1.30	<b>L&amp;M</b>	<b>LEG</b>	52.88
--------------	----------	-------	------	-------	------	----------------	------------	-------

Final Building Cleanup  
 Permanent Yard Worker

<b>S1206</b>	Group IIIB	40.97	6.24	20.66	1.30	<b>L&amp;M</b>	<b>LEG</b>	69.57
--------------	------------	-------	------	-------	------	----------------	------------	-------

Driller (including, but not limited to wagon drills, air-track drills, hydraulic drills)(over 5,000 hours)  
 Federal Powderman (Responsible Person in Charge)  
 Grade Checking (setting or transferring of grade marks, line and grade, GPS, drones)  
 Pioneer Drilling & Drilling Off Tugger (all type drills)(over 5,000 hours)  
 Stake Hopper

**Millwrights**

\*See per diem note on last page

<b>A1251</b>	Millwright (journeyman)	40.77	10.08	12.28	1.10	<b>L&amp;M</b>	0.05	64.68
--------------	-------------------------	-------	-------	-------	------	----------------	------	-------

<b>A1252</b>	Millwright Welder	41.77	10.08	12.28	1.10	<b>L&amp;M</b>	0.05	65.68
--------------	-------------------	-------	-------	-------	------	----------------	------	-------

**Painters, Region I (North of N63 latitude)**

\*See per diem note on last page

<b>N1301</b>	Group I, including:	34.19	8.71	14.30	1.08	<b>L&amp;M</b>	0.07	58.35
--------------	---------------------	-------	------	-------	------	----------------	------	-------

Brush  
 General Painter  
 Hand Taping  
 Hazardous Material Handler  
 Lead-Based Paint Abatement  
 Roll

<b>N1302</b>	Group II, including:	34.71	8.71	14.30	1.08	<b>L&amp;M</b>	0.07	58.87
--------------	----------------------	-------	------	-------	------	----------------	------	-------

Wage benefits key: BHR=basic hourly rate; H&W=health and welfare; IAF=industry advancement fund; LEG=legal fund; L&M=labor/management fund; PEN=pens fund; SAF=safety; SUI=supplemental unemployment insurance; S&L=SUI & LEG combined; TRN=training; THR=total hourly rate; VAC=vacation

**Painters, Region I (North of N63 latitude)**

\*See per diem note on last page

		BHR	H&W	PEN	TRN	Other	L&M	Benefits	THR
<b>N1302</b>	Group II, including:	34.71	8.71	14.30	1.08	0.07			58.87
	Bridge Painter								
	Epoxy Applicator								
	General Drywall Finisher								
	Hand/Spray Texturing								
	Industrial Coatings Specialist								
	Machine/Automatic Taping								
	Pot Tender								
	Sandblasting								
	Specialty Painter								
	Spray								
	Structural Steel Painter								
	Wallpaper/Vinyl Hanger								

<b>N1304</b>	Group IV, including:	39.80	8.71	17.71	1.05	0.05			67.32
	Glazier								
	Storefront/Automatic Door Mechanic								

<b>N1305</b>	Group V, including:	28.63	8.71	5.02	0.83	0.07			43.26
	Carpet Installer								
	Floor Coverer								
	Heat Weld/Cove Base								
	Linoleum/Soft Tile Installer								

**Painters, Region II (South of N63 latitude)**

\*See per diem note on last page

		BHR	H&W	PEN	TRN	Other	L&M	Benefits	THR
<b>S1301</b>	Group I, including :	31.33	8.71	15.15	1.08	0.07			56.34
	Brush								
	General Painter								
	Hand Taping								
	Hazardous Material Handler								
	Lead-Based Paint Abatement								
	Roll								
	Spray								

<b>S1302</b>	Group II, including :	32.58	8.71	15.15	1.08	0.07			57.59
	General Drywall Finisher								
	Hand/Spray Texturing								
	Machine/Automatic Taping								

Wage benefits key: BHR=basic hourly rate; H&W=health and welfare; IAF=industry advancement fund; LEG=legal fund; L&M=labor/management fund; PEN=pens fund; SAF=safety; SUI=supplemental unemployment insurance; S&L=SUI & LEG combined; TRN=training; THR=total hourly rate; VAC=vacation



Class Code	Classification of Laborers & Mechanics	BHR	H&W	PEN	TRN	Other	Benefits	THR
------------	--	-----	-----	-----	-----	-------	----------	-----

**Painters, Region II (South of N63 latitude)**  
 \*See per diem note on last page

<b>S1302</b>	Group II, including :	32.58	8.71	15.15	1.08		<b>L&amp;M</b> 0.07	57.59
--------------	-----------------------	-------	------	-------	------	--	------------------------	-------

Wallpaper/Vinyl Hanger

<b>S1303</b>	Group III, including :	32.68	8.71	15.15	1.08		<b>L&amp;M</b> 0.07	57.69
--------------	------------------------	-------	------	-------	------	--	------------------------	-------

- Bridge Painter
- Epoxy Applicator
- Industrial Coatings Specialist
- Pot Tender
- Sandblasting
- Specialty Painter
- Structural Steel Painter

<b>S1304</b>	Group IV, including:	40.01	8.71	16.75	1.08		<b>L&amp;M</b> 0.07	66.62
--------------	----------------------	-------	------	-------	------	--	------------------------	-------

- Glazier
- Storefront/Automatic Door Mechanic

<b>S1305</b>	Group V, including:	28.63	8.71	5.02	0.83		<b>L&amp;M</b> 0.07	43.26
--------------	---------------------	-------	------	------	------	--	------------------------	-------

- Carpet Installer
- Floor Coverer
- Heat Weld/Cove Base
- Linoleum/Soft Tile Installer

**Piledrivers**  
 \*See per diem note on last page

<b>A1401</b>	Piledriver	38.34	10.08	15.23	1.10		<b>L&amp;M</b> 0.10	<b>IAF</b> 0.10	64.95
--------------	------------	-------	-------	-------	------	--	------------------------	--------------------	-------

- Assistant Dive Tender
- Carpenter/Piledriver
- Rigger
- Sheet Stabber
- Skiff Operator

<b>A1402</b>	Piledriver-Welder/Toxic Worker	39.34	10.08	15.23	1.10		<b>L&amp;M</b> 0.10	<b>IAF</b> 0.10	65.95
--------------	--------------------------------	-------	-------	-------	------	--	------------------------	--------------------	-------

<b>A1403</b>	Remotely Operated Vehicle Pilot/Technician	42.65	10.08	15.23	1.10		<b>L&amp;M</b> 0.10	<b>IAF</b> 0.10	69.26
--------------	--	-------	-------	-------	------	--	------------------------	--------------------	-------

Single Atmosphere Suit, Bell or Submersible Pilot

<b>A1404</b>	Diver (working) **See note on last page	82.45	10.08	15.23	1.10		<b>L&amp;M</b> 0.10	<b>IAF</b> 0.10	109.06
--------------	---	-------	-------	-------	------	--	------------------------	--------------------	--------

Wage benefits key: BHR=basic hourly rate; H&W=health and welfare; IAF=industry advancement fund; LEG=legal fund; L&M=labor/management fund; PEN=pens fund; SAF=safety; SUI=supplemental unemployment insurance; S&L=SUI & LEG combined; TRN=training; THR=total hourly rate; VAC=vacation

Class Code	Classification of Laborers & Mechanics	BHR	H&W	PEN	TRN	Other	Benefits	THR
------------	--	-----	-----	-----	-----	-------	----------	-----

**Piledrivers**  
\*See per diem note on last page

<b>A1405</b>	Diver (standby) **See note on last page	42.65	10.08	15.23	1.10	L&M	IAF	69.26
<b>A1406</b>	Dive Tender **See note on last page	41.65	10.08	15.23	1.10	L&M	IAF	68.26
<b>A1407</b>	Welder (American Welding Society, Certified Welding Inspector)	43.90	10.08	15.23	1.10	L&M	IAF	70.51

**Plumbers, Region I (North of N63 latitude)**  
\*See per diem note on last page

<b>N1501</b>	Journeyman Pipefitter	41.91	11.25	17.20	1.50	L&M	S&L	72.51
	Plumber							
	Welder							

**Plumbers, Region II (South of N63 latitude)**  
\*See per diem note on last page

<b>S1501</b>	Journeyman Pipefitter	41.00	11.13	15.02	1.55	L&M		68.90
	Plumber							
	Welder							

**Plumbers, Region IIA (1st Judicial District)**  
\*See per diem note on last page

<b>X1501</b>	Journeyman Pipefitter	38.82	13.37	11.75	2.50	L&M		66.68
	Plumber							
	Welder							

**Power Equipment Operators**  
\*See per diem note on last page

<b>A1601</b>	Group I, including:	42.53	10.70	13.50	1.00	L&M		67.88
	Asphalt Roller: Breakdown, Intermediate, and Finish							
	Back Filler							
	Barrier Machine (Zipper)							
	Beltcrete with Power Pack & similar conveyors							
	Bending Machine							
	Boat Coxswain							
	Bulldozer							
	Cableways, Highlines & Cablecars							

Wage benefits key: BHR=basic hourly rate; H&W=health and welfare; IAF=industry advancement fund; LEG=legal fund; L&M=labor/management fund; PEN=pens fund; SAF=safety; SUI=supplemental unemployment insurance; S&L=SUI & LEG combined; TRN=training; THR=total hourly rate; VAC=vacation

**Power Equipment Operators**

\*See per diem note on last page

	<b>L&amp;M</b>						
<b>A1601</b> Group I, including:	42.53	10.70	13.50	1.00	0.10	0.05	67.88
Cleaning Machine							
Coating Machine							
Concrete Hydro Blaster							
Cranes (45 tons & under or 150 feet of boom & under (including jib & attachments))							
(a) Hydralifts or Transporters, (all track or truck type)							
(b) Derricks							
(c) Overhead							
Crushers							
Deck Winches, Double Drum							
Ditching or Trenching Machine (16 inch or over)							
Drag Scraper, Yarder, and similar types							
Drilling Machines, Core, Cable, Rotary and Exploration							
Finishing Machine Operator, Concrete Paving, Laser Screed, Sidewalk, Curb & Gutter Machine							
Grade Checker and/or Line and Grade including Drone							
Helicopters							
Hover Craft, Flex Craft, Loadmaster, Air Cushion, All-Terrain Vehicle, Rollagon, Bargecable, Nodwell, & Snow Cat							
Hydro Ax, Feller Buncher & similar							
Hydro Excavation (Vac-Truck and Similar)							
Loaders (2 1/2 yards through 5 yards, including all attachments):							
(a) Forklifts (with telescopic boom & swing attachment)							
(b) Front End & Overhead, (2-1/2 yards through 5 yards)							
(c) Loaders, (with forks or pipe clamp)							
(d) Loaders, (elevating belt type, Euclid & similar types)							
Material Transfer Vehicle (Elevating Grader, Pickup Machine, and similar types)							
Mechanic, Welder, Bodyman, Electrical, Camp & Maintenance Engineer							
Micro Tunneling Machine							
Mixers: Mobile type with hoist combination							
Motor Patrol Grader							
Mucking Machine: Mole, Tunnel Drill, Horizontal/Directional Drill Operator and/or Shield							
Off-Road Hauler (including Articulating and Haul Trucks)							
Operator on Dredges							
Piledriver Engineer, L.B. Foster, Puller or similar paving breaker							
Plant Operator (Asphalt & Concrete)							
Power Plant, Turbine Operator 200 k.w & over (power plants or combination of power units over 300 k.w.)							

Wage benefits key: BHR=basic hourly rate; H&W=health and welfare; IAF=industry advancement fund; LEG=legal fund; L&M=labor/management fund; PEN=pens fund; SAF=safety; SUI=supplemental unemployment insurance; S&L=SUI & LEG combined; TRN=training; THR=total hourly rate; VAC=vacation

<b>Power Equipment Operators</b>								
*See per diem note on last page								

<b>A1601</b>	Group I, including:	42.53	10.70	13.50	1.00	<b>L&amp;M</b>		67.88
						0.10	0.05	

- Remote Controlled Equipment
- Scraper (through 40 yards)
- Service Oiler/Service Engineer
- Shot Blast Machine
- Shovels, Backhoes, Excavators with all attachments, and Gradealls (3 yards & under)
- Sideboom (under 45 tons)
- Sub Grader (Gurries & similar types)
- Tack Tractor
- Truck Mounted Concrete Pump, Conveyor/Tele-belt, & Creter
- Wate Kote Machine

<b>A1602</b>	Group IA, including:	44.29	10.70	13.50	1.00	<b>L&amp;M</b>		69.64
						0.10	0.05	

- Camera/Tool/Video Operator (Slipline)
- Certified Welder, Electrical Mechanic, Camp Maintenance Engineer, Mechanic (over 10,000 hours)
- Cranes (over 45 tons or 150 feet including jib & attachments)
  - (a) Clamshells & Draglines (over 3 yards)
  - (b) Tower Cranes
- Licensed Water/Waste Water Treatment Operator
- Loaders (over 5 yards)
- Motor Patrol Grader, Dozer, Grade Tractor (finish: when finishing to final grade and/or to hubs, or for asphalt)
- Power Plants (1000 k.w. & over)
- Profiler, Reclaimer, and Roto-Mill
- Quad
- Scrapers (over 40 yards)
- Screed
- Shovels, Backhoes, Excavators with all attachments (over 3 yards)
- Sidebooms (over 45 tons)
- Slip Form Paver, C.M.I. & similar types
- Topside (Asphalt Paver, Slurry machine, Spreaders, and similar types)

<b>A1603</b>	Group II, including:	41.76	10.70	13.50	1.00	<b>L&amp;M</b>		67.11
						0.10	0.05	

- Boiler - Fireman
- Cement Hogs & Concrete Pump Operator
- Conveyors (except those listed in Group I)
- Hoists on Steel Erection, Towermobiles & Air Tuggers
- Horizontal/Directional Drill Locator
- Locomotives, Rod & Geared Engines

Wage benefits key: BHR=basic hourly rate; H&W=health and welfare; IAF=industry advancement fund; LEG=legal fund; L&M=labor/management fund; PEN=pens fund; SAF=safety; SUI=supplemental unemployment insurance; S&L=SUI & LEG combined; TRN=training; THR=total hourly rate; VAC=vacation

**Power Equipment Operators**

\*See per diem note on last page

<b>A1603</b> Group II, including:							<b>L&amp;M</b>	
	41.76	10.70	13.50	1.00	0.10	0.05		67.11

- Mixers
- Screening, Washing Plant
- Sideboom (cradling rock drill, regardless of size)
- Skidder
- Trenching Machines (under 16 inches)
- Water/Waste Water Treatment Operator

<b>A1604</b> Group III, including:							<b>L&amp;M</b>	
	41.04	10.70	13.50	1.00	0.10	0.05		66.39

- "A" Frame Trucks, Deck Winches
- Bombardier (tack or tow rig)
- Boring Machine
- Brooms, Power (sweeper, elevator, vacuum, or similar)
- Bump Cutter
- Compressor
- Farm Tractor
- Forklift, Industrial Type
- Gin Truck or Winch Truck (with poles when used for hoisting)
- Hoists, Air Tuggers, Elevators
- Loaders:
  - (a) Elevating-Athey, Barber Greene & similar types
  - (b) Forklifts or Lumber Carrier (on construction job sites)
  - (c) Forklifts, (with tower)
  - (d) Overhead & Front End, (under 2-1/2 yards)
- Locomotives: Dinkey (air, steam, gas & electric) Speeders
- Mechanics, Light Duty
- Oil, Blower Distribution
- Posthole Digger, Mechanical
- Pot Fireman (power agitated)
- Power Plant, Turbine Operator, (under 200 k.w.)
- Pumps, Water
- Roller (other than Asphalt)
- Saws, Concrete
- Skid Hustler
- Skid Steer (with all attachments)
- Stake Hopper
- Straightening Machine
- Tow Tractor

<b>A1605</b> Group IV, including:							<b>L&amp;M</b>	
	34.83	10.70	13.50	1.00	0.10	0.05		60.18

Wage benefits key: BHR=basic hourly rate; H&W=health and welfare; IAF=industry advancement fund; LEG=legal fund; L&M=labor/management fund; PEN=pens fund; SAF=safety; SUI=supplemental unemployment insurance; S&L=SUI & LEG combined; TRN=training; THR=total hourly rate; VAC=vacation

Class Code	Classification of Laborers & Mechanics	BHR	H&W	PEN	TRN	Other	Benefits	THR
------------	--	-----	-----	-----	-----	-------	----------	-----

**Power Equipment Operators**  
 \*See per diem note on last page

		L&M						
<b>A1605</b>	Group IV, including:	34.83	10.70	13.50	1.00	0.10	0.05	60.18
	Crane Assistant Engineer/Rig Oiler							
	Drill Helper							
	Parts & Equipment Coordinator							
	Spotter							
	Steam Cleaner							
	Swamper (on trenching machines or shovel type equipment)							

**Roofers**  
 \*See per diem note on last page

		L&M						
<b>A1701</b>	Roofer & Waterproofer	44.62	12.75	3.91	0.81	0.10	0.06	62.25
<b>A1702</b>	Roofer Material Handler	31.23	12.75	3.91	0.81	0.10	0.06	48.86

**Sheet Metal Workers, Region I (North of N63 latitude)**  
 \*See per diem note on last page

		L&M						
<b>N1801</b>	Sheet Metal Journeyman	48.64	11.50	14.11	1.65	0.12		76.02
	Air Balancing and duct cleaning of HVAC systems							
	Brazing, soldering or welding of metals							
	Demolition of sheet metal HVAC systems							
	Fabrication and installation of exterior wall sheathing, siding, metal roofing, flashing, decking and architectural sheet metal work							
	Fabrication and installation of heating, ventilation and air conditioning ducts and equipment							
	Fabrication and installation of louvers and hoods							
	Fabrication and installation of sheet metal lagging							
	Fabrication and installation of stainless steel commercial or industrial food service equipment							
	Manufacture, fabrication assembly, installation and alteration of all ferrous and nonferrous metal work							
	Metal lavatory partitions							
	Preparation of drawings taken from architectural and engineering plans required for fabrication and erection of sheet metal work							
	Sheet Metal shelving							
	Sheet Metal venting, chimneys and breaching							
	Skylight installation							

**Sheet Metal Workers, Region II (South of N63 latitude)**  
 \*See per diem note on last page

Wage benefits key: BHR=basic hourly rate; H&W=health and welfare; IAF=industry advancement fund; LEG=legal fund; L&M=labor/management fund; PEN=pens fund; SAF=safety; SUI=supplemental unemployment insurance; S&L=SUI & LEG combined; TRN=training; THR=total hourly rate; VAC=vacation

**Sheet Metal Workers, Region II (South of N63 latitude)**

\*See per diem note on last page

<b>S1801</b>	Sheet Metal Journeyman	43.20	11.50	14.09	1.68		<b>L&amp;M</b> 0.43	70.90
--------------	------------------------	-------	-------	-------	------	--	------------------------	-------

- Air Balancing and duct cleaning of HVAC systems
- Brazing, soldering or welding of metals
- Demolition of sheet metal HVAC systems
- Fabrication and installation of exterior wall sheathing, siding, metal roofing, flashing, decking and architectural sheet metal work
- Fabrication and installation of heating, ventilation and air conditioning ducts and equipment
- Fabrication and installation of louvers and hoods
- Fabrication and installation of sheet metal lagging
- Fabrication and installation of stainless steel commercial or industrial food service equipment
- Manufacture, fabrication assembly, installation and alteration of all ferrous and nonferrous metal work
- Metal lavatory partitions
- Preparation of drawings taken from architectural and engineering plans required for fabrication and erection of sheet metal work
- Sheet Metal shelving
- Sheet Metal venting, chimneys and breaching
- Skylight installation

**Sprinkler Fitters**

\*See per diem note on last page

<b>A1901</b>	Sprinkler Fitter	47.35	10.55	18.05	0.52		<b>L&amp;M</b> 0.25	76.72
--------------	------------------	-------	-------	-------	------	--	------------------------	-------

**Surveyors**

\*See per diem note on last page

<b>A2001</b>	Chief of Parties	45.16	11.83	13.14	1.15		<b>L&amp;M</b> 0.10	71.38
--------------	------------------	-------	-------	-------	------	--	------------------------	-------

<b>A2002</b>	Party Chief	43.57	11.83	13.14	1.15		<b>L&amp;M</b> 0.10	69.79
--------------	-------------	-------	-------	-------	------	--	------------------------	-------

<b>A2003</b>	Line & Grade Technician/Office Technician/GPS, Drones	42.97	11.83	13.14	1.15		<b>L&amp;M</b> 0.10	69.19
--------------	---	-------	-------	-------	------	--	------------------------	-------

<b>A2004</b>	Associate Party Chief (including Instrument Person & Head Chain Person)/Stake Hop/Grademan	40.85	11.83	13.14	1.15		<b>L&amp;M</b> 0.10	67.07
--------------	--	-------	-------	-------	------	--	------------------------	-------

<b>A2006</b>	Chain Person (for crews with more than 2 people)	36.51	11.83	13.14	1.15		<b>L&amp;M</b> 0.10	62.73
--------------	--	-------	-------	-------	------	--	------------------------	-------

Wage benefits key: BHR=basic hourly rate; H&W=health and welfare; IAF=industry advancement fund; LEG=legal fund; L&M=labor/management fund; PEN=pens fund; SAF=safety; SUI=supplemental unemployment insurance; S&L=SUI & LEG combined; TRN=training; THR=total hourly rate; VAC=vacation

**Truck Drivers**

\*See per diem note on last page

							L&M	
<b>A2101</b>	Group I, including:	41.94	11.83	13.14	1.15	0.10		68.16
	Air/Sea Traffic Controllers							
	Ambulance/Fire Truck Driver (EMT certified)							
	Boat Coxswain							
	Captains & Pilots (air & water)							
	Deltas, Commanders, Rollagons, & similar equipment (when pulling sleds, trailers or similar equipment)							
	Dump Trucks (including rockbuggy, side dump, belly dump, & trucks with pups) over 40 yards up to & including 60 yards							
	Helicopter Transporter							
	Liquid Vac Truck/Super Vac Truck							
	Material Coordinator or Purchasing Agent							
	Ready-mix (over 12 yards up to & including 15 yards) (over 15 yards to be negotiated)							
	Semi with Double Box Mixer							
	Tireman, Heavy Duty/Fueler							
	Water Wagon (250 Bbls and above)							
<b>A2102</b>	Group 1A including:	43.21	11.83	13.14	1.15	0.10		69.43
	Dump Trucks (including rockbuggy, side dump, belly dump & trucks with pups) over 60 yards up to & including 100 yards (over 100 yards to be negotiated)							
	Jeeps (driver under load)							
	Lowboys, including tractor attached trailers & jeeps, up to & including 12 axles (over 12 axles or 150 tons to be negotiated)							
<b>A2103</b>	Group II, including:	40.68	11.83	13.14	1.15	0.10		66.90
	All Deltas, Commanders, Rollagons, & similar equipment							
	Batch Trucks (8 yards & up)							
	Batch Trucks (up to & including 7 yards)							
	Boom Truck/Knuckle Truck (over 5 tons)							
	Cacasco Truck/Heat Stress Truck							
	Construction and Material Safety Technician							
	Dump Trucks (including rockbuggy, side dump, belly dump, & trucks with pups) over 20 yards up to & including 40 yards							
	Gin Pole Truck, Winch Truck, Wrecker (truck mounted "A" frame manufactured rating over 5 tons)							
	Mechanics							
	Oil Distributor Driver							
	Partsman							
	Ready-mix (up to & including 12 yards)							
	Stringing Truck							

Wage benefits key: BHR=basic hourly rate; H&W=health and welfare; IAF=industry advancement fund; LEG=legal fund; L&M=labor/management fund; PEN=pens fund; SAF=safety; SUI=supplemental unemployment insurance; S&L=SUI & LEG combined; TRN=training; THR=total hourly rate; VAC=vacation



**Truck Drivers**

\*See per diem note on last page

<b>A2103</b>	Group II, including:	40.68	11.83	13.14	1.15		<b>L&amp;M</b> 0.10	66.90
	Turn-O-Wagon or DW-10 (not self loading)							
<b>A2104</b>	Group III, including:	39.86	11.83	13.14	1.15		<b>L&amp;M</b> 0.10	66.08
	Boom Truck/Knuckle Truck (up to & including 5 tons)							
	Dump Trucks (including rockbuggy, side dump, belly dump, & trucks with pups) over 10 yards up to & including 20 yards							
	Expeditor (electrical & pipefitting materials)							
	Gin Pole Truck, Winch Truck, Wrecker (truck mounted "A" frame manufactured rating 5 tons & under)							
	Greaser - Shop							
	Semi or Truck & Trailer							
	Thermal Plastic Layout Technician							
	Traffic Control Technician							
	Trucks/Jeeps (push or pull)							
<b>A2105</b>	Group IV, including:	39.28	11.83	13.14	1.15		<b>L&amp;M</b> 0.10	65.50
	Air Cushion or similar type vehicle							
	All Terrain Vehicle							
	Buggymobile							
	Bull Lift & Fork Lift, Fork Lift with Power Boom & Swing Attachment (over 5 tons)							
	Bus Operator (over 30 passengers)							
	Cement Spreader, Dry							
	Combination Truck-Fuel & Grease							
	Compactor (when pulled by rubber tired equipment)							
	Dump Trucks (including rockbuggy, side dump, belly dump, & trucks with pups) up to & including 10 yards							
	Dumpster							
	Expeditor (general)							
	Fire Truck/Ambulance Driver							
	Flat Beds, Dual Rear Axle							
	Foam Distributor Truck Dual Axle							
	Front End Loader with Fork							
	Grease Truck							
	Hydro Seeder, Dual Axle							
	Hyster Operators (handling bulk aggregate)							
	Loadmaster (air & water operations)							
	Lumber Carrier							
	Ready-mix, (up to & including 7 yards)							
	Rigger (air/water/oilfield)							

Wage benefits key: BHR=basic hourly rate; H&W=health and welfare; IAF=industry advancement fund; LEG=legal fund; L&M=labor/management fund; PEN=pens fund; SAF=safety; SUI=supplemental unemployment insurance; S&L=SUI & LEG combined; TRN=training; THR=total hourly rate; VAC=vacation

**Truck Drivers**  
 \*See per diem note on last page

						L&M	
<b>A2105</b>	Group IV, including:	39.28	11.83	13.14	1.15	0.10	65.50
	Tireman, Light Duty						
	Track Truck Equipment						
	Truck Vacuum Sweeper						
	Warehouseperson						
	Water Truck (Below 250 Bbls)						
	Water Truck (straight)						
	Water Wagon, Semi						

						L&M	
<b>A2106</b>	Group V, including:	38.52	11.83	13.14	1.15	0.10	64.74
	Buffer Truck						
	Bull Lifts & Fork Lifts, Fork Lifts with Power Boom & Swing Attachments (up to & including 5 tons)						
	Bus Operator (up to 30 passengers)						
	Farm Type Rubber Tired Tractor (when material handling or pulling wagons on a construction project)						
	Flat Beds, Single Rear Axle						
	Foam Distributor Truck Single Axle						
	Fuel Handler (station/bulk attendant)						
	Gear/Supply Truck						
	Gravel Spreader Box Operator on Truck						
	Hydro Seeders, Single axle						
	Pickups (pilot cars & all light-duty vehicles)						
	Rigger/Swamper						
	Tack Truck						
	Team Drivers (horses, mules, & similar equipment)						

**Tunnel Workers, Laborers (The Alaska areas north of N63 latitude and east of W138 longitude)**  
 \*See per diem note on last page

						L&M	LEG	
<b>N2201</b>	Group I, including:	35.20	8.95	20.66	1.30	0.20	0.20	66.51
	Brakeman							
	Mucker							
	Nipper							
	Storm Water Pollution Protection Plan Worker (SWPPP Worker - erosion and sediment control Laborer)							
	Topman & Bull Gang							
	Tunnel Track Laborer							

						L&M	LEG	
<b>N2202</b>	Group II, including:	36.30	8.95	20.66	1.30	0.20	0.20	67.61
	Burning & Cutting Torch							

Wage benefits key: BHR=basic hourly rate; H&W=health and welfare; IAF=industry advancement fund; LEG=legal fund; L&M=labor/management fund; PEN=pens fund; SAF=safety; SUI=supplemental unemployment insurance; S&L=SUI & LEG combined; TRN=training; THR=total hourly rate; VAC=vacation

**Tunnel Workers, Laborers (The Alaska areas north of N63 latitude and east of W138 longitude)**  
 \*See per diem note on last page

						L&M	LEG	
<b>N2202</b>	Group II, including:	36.30	8.95	20.66	1.30	0.20	0.20	67.61
	Certified Erosion Sediment Control Lead (CESCL Laborer)							
	Concrete Laborer							
	Floor Preparation, Core Drilling							
	Jackhammer/Chipping Gun or Pavement Breaker							
	Laser Instrument Operator							
	Nozzlemen, Pumpcrete or Shotcrete							
	Pipelayer Helper							

						L&M	LEG	
<b>N2203</b>	Group III, including:	37.29	8.95	20.66	1.30	0.20	0.20	68.60
	Miner							
	Retimberman							

						L&M	LEG	
<b>N2204</b>	Group IIIA, including:	40.90	8.95	20.66	1.30	0.20	0.20	72.21
	Asphalt Raker, Asphalt Belly Dump Lay Down							
	Drill Doctor (in the field)							
	Driller (including, but not limited to wagon drills, air-track drills, hydraulic drills)							
	Pioneer Drilling & Drilling Off Tugger (all type drills)							
	Pipelayer							
	Powderman (Employee Possessor)							
	Storm Water Pollution Protection Plan Specialist (SWPPP Specialist)							
	Traffic Control Supervisor, DOT Qualified							

						L&M	LEG	
<b>N2206</b>	Group IIIB, including:	45.07	6.24	20.66	1.30	0.20	0.20	73.67
	Driller (including, but not limited to wagon drills, air-track drills, hydraulic drills)(over 5,000 hours)							
	Federal Powderman (Responsible Person in Charge)							
	Grade Checking (setting or transferring of grade marks, line and grade, GPS, drones)							
	Pioneer Drilling & Drilling Off Tugger (all type drills)(over 5,000 hours)							
	Stake Hopper							

**Tunnel Workers, Laborers (The area that is south of N63 latitude and west of W138 longitude)**  
 \*See per diem note on last page

						L&M	LEG	
<b>S2201</b>	Group I, including:	35.20	8.95	20.66	1.30	0.20	0.20	66.51
	Brakeman							
	Mucker							

Wage benefits key: BHR=basic hourly rate; H&W=health and welfare; IAF=industry advancement fund; LEG=legal fund; L&M=labor/management fund; PEN=pens fund; SAF=safety; SUI=supplemental unemployment insurance; S&L=SUI & LEG combined; TRN=training; THR=total hourly rate; VAC=vacation

**Tunnel Workers, Laborers (The area that is south of N63 latitude and west of W138 longitude)**  
 \*See per diem note on last page

<b>S2201</b>	Group I, including:	35.20	8.95	20.66	1.30		<b>L&amp;M</b>	<b>LEG</b>	66.51
--------------	---------------------	-------	------	-------	------	--	----------------	------------	-------

- Nipper
- Storm Water Pollution Protection Plan Worker (SWPPP Worker - erosion and sediment control Laborer)
- Topman & Bull Gang
- Tunnel Track Laborer

<b>S2202</b>	Group II, including:	36.30	8.95	20.66	1.30		<b>L&amp;M</b>	<b>LEG</b>	67.61
--------------	----------------------	-------	------	-------	------	--	----------------	------------	-------

- Burning & Cutting Torch
- Certified Erosion Sediment Control Lead (CESCL Laborer)
- Concrete Laborer
- Floor Preparation, Core Drilling
- Jackhammer/Chipping Gun or Pavement Breaker
- Laser Instrument Operator
- Nozzlemen, Pumpcrete or Shotcrete
- Pipelayer Helper

<b>S2203</b>	Group III, including:	37.29	8.95	20.66	1.30		<b>L&amp;M</b>	<b>LEG</b>	68.60
--------------	-----------------------	-------	------	-------	------	--	----------------	------------	-------

- Miner
- Retimberman

<b>S2204</b>	Group IIIA, including:	40.90	8.95	20.66	1.30		<b>L&amp;M</b>	<b>LEG</b>	72.21
--------------	------------------------	-------	------	-------	------	--	----------------	------------	-------

- Asphalt Raker, Asphalt Belly Dump Lay Down
- Drill Doctor (in the field)
- Driller (including, but not limited to wagon drills, air-track drills, hydraulic drills)
- Pioneer Drilling & Drilling Off Tugger (all type drills)
- Pipelayer
- Powderman (Employee Possessor)
- Storm Water Pollution Protection Plan Specialist (SWPPP Specialist)
- Traffic Control Supervisor, DOT Qualified

<b>S2206</b>	Group IIIB, including:	45.07	6.24	20.66	1.30		<b>L&amp;M</b>	<b>LEG</b>	73.67
--------------	------------------------	-------	------	-------	------	--	----------------	------------	-------

- Driller (including, but not limited to wagon drills, air-track drills, hydraulic drills)(over 5,000 hours)
- Federal Powderman (Responsible Person in Charge)
- Grade Checking (setting or transferring of grade marks, line and grade, GPS, drones)
- Pioneer Drilling & Drilling Off Tugger (all type drills)(over 5,000 hours)

Wage benefits key: BHR=basic hourly rate; H&W=health and welfare; IAF=industry advancement fund; LEG=legal fund; L&M=labor/management fund; PEN=pens fund; SAF=safety; SUI=supplemental unemployment insurance; S&L=SUI & LEG combined; TRN=training; THR=total hourly rate; VAC=vacation

Class Code	Classification of Laborers & Mechanics	BHR	H&W	PEN	TRN	Other	Benefits	THR
------------	--	-----	-----	-----	-----	-------	----------	-----

**Tunnel Workers, Laborers (The area that is south of N63 latitude and west of W138 longitude)**  
 \*See per diem note on last page

<b>S2206</b>	Group IIIB, including:	45.07	6.24	20.66	1.30		<b>L&amp;M</b>	<b>LEG</b>	
	Stake Hopper						0.20	0.20	73.67

**Tunnel Workers, Power Equipment Operators**  
 \*See per diem note on last page

<b>A2207</b>	Group I	46.78	10.70	13.50	1.00		<b>L&amp;M</b>		
							0.10	0.05	72.13
<b>A2208</b>	Group IA	48.72	10.70	13.50	1.00		<b>L&amp;M</b>		
							0.10	0.05	74.07
<b>A2209</b>	Group II	45.94	10.70	13.50	1.00		<b>L&amp;M</b>		
							0.10	0.05	71.29
<b>A2210</b>	Group III	45.14	10.70	13.50	1.00		<b>L&amp;M</b>		
							0.10	0.05	70.49
<b>A2211</b>	Group IV	38.31	10.70	13.50	1.00		<b>L&amp;M</b>		
							0.10	0.05	63.66

\* Per diem is an established practice for this classification. This means that per diem is an allowable alternative to board and lodging if all criteria are met. See 8 AAC 30.051-08 AAC 30.056, and the per diem information on page vii of this Pamphlet.

\*\* Work in combination of classifications: Employees working in any combination of classifications within the diving crew (working diver, standby diver, and tender) in a shift are paid in the classification with the highest rate for a minimum of 8 hours per shift.

Wage benefits key: BHR=basic hourly rate; H&W=health and welfare; IAF=industry advancement fund; LEG=legal fund; L&M=labor/management fund; PEN=pens fund; SAF=safety; SUI=supplemental unemployment insurance; S&L=SUI & LEG combined; TRN=training; THR=total hourly rate; VAC=vacation

## **SECTION 00852 – PERMITS**

### **PART 1 - GENERAL**

#### **1.1 INDEX OF PERMITS**

- A. CONTRACTOR will be required to submit a Traffic Control Plan and a CBJ Right-of-Way permit application to CBJ Engineering Department for approval at the pre-construction conference.

### **PART 2 – PRODUCTS (Not Used)**

### **PART 3 – EXECUTION (Not Used)**

**END OF SECTION**

## SECTION 00853 – STANDARD DETAILS

### PART 1 - GENERAL

#### 1.1 STANDARD DETAILS

- A. Whenever references are made to the Standard Drawings or Standard Details in these Plans or Specifications, the intent is to refer to the current City and Borough of Juneau Standard Details (currently the 4th Edition dated August 2011), copies of which may be purchased from the CBJ Engineering Department.
- B. City and Borough of Juneau Standard Details which specifically apply to this Project include but are not limited to the following:

#### **STANDARD**

#### **DETAIL NO.**

#### **NAME OF DETAIL**

104A	CULVERT HEADWALL WITH HINGED TRASH RACK
106	ACCESSIBLE SIDEWALK RAMP
111A	CONCRETE SIDEWALK TYPE I CURB & GUTTER
116	CANTILEVERED SINGLE MAILBOX
117	CANTILEVERED GANG MAILBOX
118	STREET LIGHTING
119A	JUNCTION BOX TYPE I & TYPE IA
125	PAVEMENT RESURFACING AND TRENCH DETAIL
126	CONCRETE COLLAR
127A	SIGN ASSEMBLY SINGLE-POST
203	SANITARY SEWER MANHOLE TYPES I & II
205	MANHOLE HEIGHTS
206A	STANDARD MANHOLE COVER & FRAME
209	MANHOLE CONNECTION DETAILS
213	SANITARY SEWER SERVICE LATERAL
215	SANITARY SEWER CROSSING
218	COUPLING FOR DISSIMILAR SANITARY SEWER PIPES
303	STORM DRAIN MANHOLE TYPES I & II
304A	TYPE III CATCH BASIN
304B	TYPE IV CATCH BASIN
306	STORM DRAIN MANHOLE COVER & FRAME
307	STORM DRAIN SERVICE LATERAL
308	CURB INLET FRAME, GRATE & HOOD
309	LOCAL DEPRESSION AT CATCH BASIN
310	AREA DRAIN DETAIL
403	FIRE HYDRANT
404	HYDRANT GUARD POSTS
405	HYDRANT PAD
406A	WATER SERVICE
406B	DUCTILE IRON WATER SERVICE
407	MAINLINE VALVE
409	AIR RELEASE VALVE
412	RIGID INSULATION
414A	DOWNWARD CONCAVE THRUST BLOCK
414B	HORIZONTAL AND CONCAVE UPWARD THRUST BLOCK

**PART 2 – PRODUCTS** (Not Used)

**PART 3 – EXECUTION** (Not Used)

**END OF SECTION**

# PROJECT MANUAL

---

## TONGASS BOULEVARD RECONSTRUCTION PHASE 1 Juneau, Alaska

CBJ Contract No. BE21-150

April 7, 2021

---



### **PDC ENGINEERS**

9109 Mendenhall Mall Rd. Ste 4  
Juneau, Alaska 99801

Phone (907) 780-6060

Fax (907) 586-3771

[KevinPuustinen@pdceng.com](mailto:KevinPuustinen@pdceng.com)



## SPECIAL PROVISIONS

The Standard Specifications for Civil Engineering Projects and Subdivision Improvements December 2003 Edition, with sixteen (16) Errata Sheets, as published by the City and Borough of Juneau, is part of these Contract Documents and shall pertain to all phases of the contract. The Standard Specifications for Civil Engineering Projects and Subdivision Improvements December 2003 Edition is available for a fee from the City and Borough of Juneau Engineering Contracts Office, (907) 586-0490, or you may view them online at: [www.juneau.org/engineering](http://www.juneau.org/engineering).

### Special Provisions – Table of Contents

<b>Section No.</b>	<b>Section Title</b>	<b>Page No.</b>
01010	Summary of Work	2
01025	Measurement and Payment	5
01550	Site Access and Storage	28
01570	Erosion and Sediment Control	28
01700	Project Close-Out	28
02202	Excavation and Embankment	34
02203	Trenching	34
02204	Base Course	34
02401	Sanitary Sewer Pipe	34
02402	Sanitary Sewer Manholes and Cleanouts	35
02501	Storm Sewer Pipe	35
02502	Storm Sewer Manholes, Inlets and Catch Basins	36
02601	Water Pipe	36
02605	Water Services	37
02702	Construction Surveying	37
02709	Topsoil	37
02716	Storm and Sanitary Sewer Pipe Removal and Water Pipe Slurry	38
02718	Sign Assembly	39
02722	Electrical Utilities	39
02723	Remove and Relocate Landscaping	40
02801	Asphalt Concrete Pavement	41
03302	Concrete Structures	44
03303	Sidewalk, Curb and Gutter	44
260000	General Electrical Requirements	45
260519	Low Voltage Electrical Power Conductors and Cables	56
260526	Grounding and Bonding for Electrical Systems	58
260533	Raceways and Boxes for Electrical Systems	60
260553	Identification for Electrical Systems	64
262816	Enclosed Switches and Circuit Breakers	66

## SPECIAL PROVISIONS

*Add the following Section:*

### SECTION 01010 - SUMMARY OF WORK

#### PART 1 - GENERAL

##### 1.1 GENERAL

- A. The WORK to be performed under this contract shall consist of furnishing all plant, tools, equipment, materials, supplies, manufactured articles and furnishing all labor, transportation and services, including all fuel, power, water and essential communications and performing all WORK, or other operations required for the fulfillment of the contract in strict accordance with the Contract Documents. The WORK shall be complete, and all WORK, materials, and services, not expressly indicated or called for in the Contract Documents which may be necessary for the complete and proper construction of the WORK in good faith shall be provided by the CONTRACTOR as though originally so indicated, at no increase in cost to the OWNER.

##### 1.2 WORK COVERED BY CONTRACT DOCUMENTS

- A. The WORK covered in the Contract Documents includes reconstruction of Tongass Boulevard from the intersection of Trinity Drive to Dudley Street. Work generally includes clearing and grubbing, excavation, 2" minus shot rock with D-1 base course, storm drain improvements, replacement of existing water main, new water services, new fire hydrants, replacement of existing sewer main line, new sewer services, new sanitary sewer manholes, asphalt pavement, asphalt sidewalk, curb & gutter, mailboxes, traffic control signs, lighting, and other miscellaneous related WORK.
- B. The WORK must be completed by October 1, 2021 or 120 days from commencement of work, whichever comes first.
- C. SITE OF WORK. The site of WORK is Tongass Boulevard located in the Mendenhall Valley in Juneau, Alaska.

##### 1.3 WORK BY OTHERS

- A. The CONTRACTOR's attention is directed to the fact that work may be conducted at the site by other contractors during the performance of the WORK under this contract. The CONTRACTOR shall conduct its operations so as to cause a minimum of interference with the WORK of such other contractors, and shall cooperate fully with such contractors to provide continued safe access to their respective portions of the site, as required to perform work under their respective contracts.
- B. Interference with Work on Utilities. The CONTRACTOR shall cooperate fully with all utility forces of the OWNER or private agencies engaged in the relocation, altering, or otherwise rearranging of any facilities which interfere with the progress of the WORK, and shall schedule the WORK so as to minimize interference with said relocation, altering, or other rearranging of facilities.

## SPECIAL PROVISIONS

### 1.4 CONTRACTOR USE OF PROJECT SITE

- A. The CONTRACTOR's use of the Project site shall include construction operations and storage of materials, fabrication facilities, and field offices only in those areas identified on the Drawings.

### 1.5 OWNER USE OF THE PROJECT SITE

- A. The OWNER may utilize all or part of the existing site during the entire period of construction for the conduct of the OWNER's normal operations. The CONTRACTOR shall cooperate and coordinate with the ENGINEER to facilitate the OWNER's operations and to minimize interference with the CONTRACTOR's operation at the same time. In any event, the OWNER shall be allowed access to the Project site during the period of construction.

### 1.6 PROJECT MEETINGS

#### A. Pre-Construction Conference

1. Prior to the commencement of WORK at the site, a Pre-Construction Conference will be held at a mutually agreed time and place which shall be attended by the CONTRACTOR's Project Manager, its superintendent, and its Subcontractors as the CONTRACTOR deems appropriate. Other attendants will be:
  - a. ENGINEER and Inspector.
  - b. Representatives of OWNER.
  - c. Governmental representatives as appropriate.
  - d. Others as requested by CONTRACTOR, OWNER, or ENGINEER.
2. Unless previously submitted to the ENGINEER, the CONTRACTOR shall bring to the Pre-Construction Conference one copy each of the following:
  - a. Plan of Operation.
  - b. Project Overview Bar Chart Schedule.
  - c. Procurement schedule of major equipment and materials and items requiring long lead time.
  - d. Shop Drawing/Sample/Substitute or "Or Equal" submittal schedule.
  - e. Name and telephone number of CONTRACTOR's Project Supervisor.
  - f. Erosion Control Plan.
  - g. Traffic Control Plan and CBJ Right-of-Way permit application.
3. The purpose of the Pre-Construction Conference is to designate responsible personnel and establish a working relationship. Matters requiring coordination will be discussed and procedure for handling such matters established. The complete agenda will be furnished to the CONTRACTOR prior to the meeting date. The CONTRACTOR should be prepared to discuss all the items listed below:
  - a. Status of CONTRACTOR's insurance and bonds.
  - b. CONTRACTOR's tentative construction schedules.
  - c. Transmittal, review, and distribution of CONTRACTOR's submittals.
  - d. Processing applications for payment.

## SPECIAL PROVISIONS

- e. Maintaining record documents.
  - f. Critical WORK sequencing and long lead items.
  - g. Field decisions and Change Orders.
  - h. Use of Project site, office and storage areas, security, housekeeping, and OWNER's needs.
  - i. Major equipment deliveries and priorities.
  - j. CONTRACTOR's assignments for safety and first aid.
4. The OWNER will preside at the Pre-Construction Conference and will arrange for keeping and distributing the minutes to all persons in attendance.
  5. The CONTRACTOR and its Subcontractors should plan on the conference taking no longer than three hours. Items listed in paragraph 3 will be covered as well as a review of the Drawings and Specifications with the ENGINEER and OWNER.

### B. Progress Meetings

1. The CONTRACTOR shall schedule and hold regular on-site progress meetings at least weekly and at other times as requested by the ENGINEER, or as required by the progress of the WORK. The CONTRACTOR, ENGINEER, and all Subcontractors active on the site must attend each meeting. CONTRACTOR may at its discretion request attendance by representatives of its Suppliers, manufacturers, and other Subcontractors.
2. The ENGINEER shall conduct the meeting and will arrange for recording and distributing the minutes. The purpose of the meetings will be to review the progress of the WORK, maintain coordination of efforts, discuss changes in scheduling, and resolve other problems which may develop. During each meeting, the CONTRACTOR is required to present any issues which may impact the WORK, with a view toward resolving these issues expeditiously.

## 1.7 DEFINITIONS APPLICABLE TO TECHNICAL SPECIFICATIONS

### A. The following words have the meaning defined in the Technical Portions of the WORK:

1. **Furnish** - means to supply and deliver to the site, to unload and unpack ready for assembly, installation, testing, and start-up.
2. **Indicated** - is a word used to direct the CONTRACTOR to information contained on the drawings or in the Specifications. Terms such as "shown", "noted", "scheduled", and "specified" also may be used to assist in locating information but no limitation of location is implied or intended.
3. **Install** - defines operations at the site including assembly, erection, placing, anchoring, applying, shaping to dimension, finishing, curing, protecting, and cleaning, ready for the OWNER's use.
4. **Installer** - a person or firm engaged by the CONTRACTOR or its subcontract, or any Subcontractor, for the performance of installation, erection, or application WORK at the site. Installers must be expert in the operations they are engaged to perform.
5. **Provide** - is defined as furnish and install, ready for the intended use.

## PART 2 - PRODUCTS (Not Used)

## **SPECIAL PROVISIONS**

### **PART 3 - EXECUTION (Not Used)**

#### **END OF SECTION**

*Add the following Section:*

### **SECTION 01025 – MEASUREMENT AND PAYMENT**

#### **PART 1 - GENERAL**

##### **1.1 SCOPE**

- A. Payment for the various items of the Bid Schedule, as further specified herein, shall include all compensation to be received by the CONTRACTOR for furnishing all tools, equipment, supplies, and manufactured articles, and for all labor, operations, and incidentals appurtenant to the items for WORK being described, as necessary to complete the various items of the WORK all in accordance with the requirements of the Contract Documents, including all appurtenances thereto, and including all costs of permits and cost of compliance with the regulations of public agencies having jurisdiction, including Safety and Health Requirements of Occupational Safety and Health Administration of the U.S. Department of Labor (OSHA) and Occupational Safety and Health Standards of the Alaska Department of Labor, Division of Labor Standards and Safety.
  
- B. No separate payment will be made for any Pay Item that is not specifically set forth in the Bid Schedule, and all costs therefore shall be included in the prices named in the Bid Schedule for the various appurtenant items of WORK.
  
- C. In addition to the other incidental items of WORK listed elsewhere in the contract, the following items shall also be considered as incidental to other items of WORK under this contract:
  - 1. Maintenance of all services through the Project area including power, water, storm and sanitary sewers, garbage pickup, mail delivery and emergency vehicles.
  - 2. Traffic control, including flaggers, and installation and maintenance of traffic control devices in accordance with the Manual of Uniform Traffic Control Devices – Millennium Edition (MUTCD) and the current AKDOT&PF supplements.
  - 3. Repair or replacement of existing adjacent facilities including piping, landscaping, steel, timber, concrete, and asphalt items, if damaged by the CONTRACTOR.
  - 4. Final clean-up and site restoration.
  - 5. All WORK necessary for coordination of work to be accomplished by the private utility companies and property owners within the Project limits.
  - 6. Removal and replacement of survey monuments and markers disturbed during construction, whether shown on the Drawings or not.
  - 7. All fittings (except CPP saddle tees) required for storm, water, and sanitary sewer pipes.
  - 8. Watering of the roadway as necessary for dust control.
  - 9. Crack sealing all sawcut pavement joints following paving operations.
  - 10. All WORK related to dewatering including providing necessary pumps, temporary piping, sump drain rock, installing well points, sumps and French drains and other control measures to keep trench excavations for underground utilities and structures free of water.

## SPECIAL PROVISIONS

11. Shoring and supporting existing above ground utility poles.
12. Sheeting, shoring, and bracing as required.
13. Restoration and grading of all disturbed areas as necessary to provide a smooth transition to existing lot surfaces.
14. All WORK required to notify utility users of pending utility shutdowns.
15. All pavement saw cutting required for connections to existing asphalt pavement surfaces, concrete surfaces, and concrete curbs.
16. Furnishing and installing all temporary construction fencing necessary during construction.
17. Placement and compaction of useable excavation in the ditches, including restoration and grading of all disturbed areas as necessary to create a smooth transition to the existing surfaces adjacent the project.
18. All restrained joints required for water pipe.
19. Rotating and adjusting existing frame & grates to align with new curb & gutter located at stations "T"14+39, 44' LT and "T"14+77, 39' LT.
20. Removal & resetting of existing stop sign located at station "T"19+24, 15' LT.
21. 8" PVC pipe and fittings required to connect with the existing pipe located at station "T"16+55, 21' LT.

### 1.2 MOBILIZATION (Pay Item No. 1505.1) PRICE BASED ON LUMP SUM PAY UNIT

- A. Measurement for payment for Mobilization will be based upon the completion of the entire WORK as a Lump Sum Pay Unit, complete, all in accordance with the requirements of the Contract Documents.
- B. Payment for Mobilization will be made at the amount shown on the Bid Schedule under Pay Item No. 1505.1, which payment will constitute full compensation for all WORK described in Section 01505 - Mobilization, as shown on the Drawings and as directed by the ENGINEER.
- C. Partial payments will be made as the WORK progresses as follows:
  1. When 5% of the total original contract amount is earned from other Pay Items, 50% of the amount bid for Mobilization, or 5% of the original contract amount, whichever is lesser, will be paid.
  2. When 10% of the total original contract amount is earned from other Pay Items, 100% of the amount bid for Mobilization, or 10% of the original contract amount, whichever is lesser, will be paid.
  3. Upon completion of all WORK on the Project, payment of any amount bid for Mobilization in excess of 10% of the total contract amount will be paid.

### 1.3 EROSION AND SEDIMENT CONTROL (Pay Item No. 1570.1) PRICE BASED ON LUMP SUM PAY UNIT

- A. Measurement for payment for Erosion and Sediment Control will be based upon the completion of the entire WORK as a Lump Sum Pay Unit, complete, all in accordance with the requirements of the Contract Documents.
- B. WORK under this Pay Item includes all requirements described in Section 01570, including but not limited to preparation of SWPPP, obtaining all necessary permits for storm water control as required by Alaska Department of Environmental Conservation and the Environmental Protection Agency. This includes furnishing, installing, and maintaining all

## SPECIAL PROVISIONS

SWPPP BMP measures required by these permits. SWPPP management, SWPPP inspection records and SWPPP reporting is included as part of this WORK.

- C. Payment for Erosion and Sediment Control will be made at the Unit Price named in the Bid Schedule under Pay Item No. 1570.1, which payment will constitute full compensation for all WORK described in Section 01570 – Erosion Control, as shown on the Drawings and as directed by the ENGINEER.

### 2.1 CLEARING AND GRUBBING (Pay Item No. 2201.1) PRICE BASED ON LUMP SUM PAY UNIT

- A. Measurement for payment for Clearing and Grubbing will be based upon the completion of the entire WORK as a Lump Sum Pay Unit, complete, all in accordance with the requirements of the Contract Documents.
- B. WORK under this Pay Item includes cutting, limbing, removal and disposal of trees within the WORK limits as shown on the Drawings and as approved by the ENGINEER. This WORK includes removal and disposal of tree stumps and root wads at an off-site location as approved by the ENGINEER. Useable excavation from excavation shall be used to fill the void left by the removal of the root wad unless otherwise shown on the Drawings or directed by the ENGINEER. WORK under this Pay Item includes removal and disposal of organic material from ditches prior to placing usable excavation as shown on the Drawings.
- C. Payment for Clearing and Grubbing will be made at the amount shown on the Bid Schedule under Pay Item No. 2201.1, which payment will constitute full compensation for all WORK described in Section 02201 – Clearing and Grubbing, as shown on the Drawings and as directed by the ENGINEER.

### 2.2 EXCAVATION (Pay Item No. 2202.1) PRICE BASED ON QUANTITY, CUBIC YARD

- A. Measurement for payment for Excavation will be based on the number of cubic yards of unclassified material actually excavated, as determined by the average end area method. Where impractical to measure by the average end area method, the ENGINEER may approve other acceptable methods involving three-dimensional measurements. Excavation outside of the subcut limits indicated in the Drawings will not be measured for payment.
- B. No deduction in the measurement for Excavation will be made for the trenching required for pipe and structure installations above the bottom of, or within the subcut limits as shown on the Typical Sections.
- C. Measurement for payment may be selected by the CONTRACTOR from one of the following methods:
  - 1. From actual cross sections taken by the CONTRACTOR's surveyor, with the lower limits determined by the neat line subcut limits as indicated on the Typical Sections, or as directed by the ENGINEER.
  - 2. The CONTRACTOR may review and utilize the ENGINEER's design earthwork quantity computations in lieu of providing its own quantity determinations.
- D. Additional trench excavation directed by the ENGINEER greater than 6-inches below the invert of the storm drain pipe, sewer utility pipe or water utility pipe will be measured for

## SPECIAL PROVISIONS

payment under this pay item. Measurement will be based on the number of yards actually excavated and will be limited to a depth of 2-feet.

E. The following will not be measured for direct payment; the cost of such WORK will be considered incidental:

1. Overburden and other spoil material from borrow sources.
2. Removal of water by aeration of material to obtain required moisture content.
3. Any volumes of water or other liquid material.
4. Material used for the purpose other than directed.
5. Roadbed material scarified in place and not removed.
6. Material excavated when benching.
7. Slide or slipout material attributable to the carelessness of the CONTRACTOR.
8. The volume of conserved materials stockpiled at the option of the CONTRACTOR.
9. Placement of usable, or otherwise suitable material from excavation, as determined by the ENGINEER, into the new roadway as embankment or selected embankment, or between the bottom of the 2-inch minus shot rock and the top of the underdrain level, or as embankment for any areas outside the roadway subcut within the project limits, including under sidewalks.

F. Payment for Excavation will be made at the Unit Price named in the Bid Schedule under Pay Item No. 2202.1, which payment will constitute full compensation for all WORK described in Section 02202 - Excavation and Embankment, as shown on the Drawings and as directed by the ENGINEER.

### 2.3 SIDESLOPES AND DITCH GRADING (Pay Item No. 2202.2) PRICE BASED ON LUMP SUM PAY UNIT

- A. Measurement for payment for Sideslopes and Ditch Grading will be based on the completion of the entire WORK as a Lump Sum Pay Unit, complete, including all excavation and placement of usable material from excavation into the sideslopes behind the sidewalk and curb & gutter shoulder limits, all in accordance with the requirements of the Contract Documents.
- B. This Pay Item will include all WORK, including excavation, backfill with usable material from roadway excavation, and all grading behind the sidewalk and base course grading D-1 shoulder limits as necessary to construct smooth graded areas to the existing yard match lines, and other graded areas as shown on the Drawings and as directed by the ENGINEER.
- C. Payment for Sideslopes and Ditch Grading will be made at the amount named in the Bid Schedule under Pay Item No. 2202.2, which will constitute full compensation for all WORK described in section 02202 – Excavation and Embankment, as shown on the Drawings and as directed by the ENGINEER.

### 2.4 MINING AREA RESTORATION & ROAD CLEANING GUARANTEE (Pay Item No. 2202.3) PRICE BASED ON CONTINGENT SUM PAY UNIT

- A. Measurement for this Item will be made as a Contingent Sum Pay Unit for completion of Mining Area Restoration and Road Cleaning.



## SPECIAL PROVISIONS

- B. The CONTRACTOR shall be responsible for removal of dirt, mud, rocks and other debris from CBJ and State Right-of-Ways accumulated from the hauling and quarry operations. It is the intent that the traveled public way be kept as clean as practical to minimize dust and to avoid unsafe traffic conditions. If the CONTRACTOR fails to perform necessary road cleaning in a timely manner, the CBJ may hire outside forces to perform the WORK and deduct the cost from this contingent sum item.
- C. The Contractor shall be responsible for restoration of their mining area in accordance to the conditions of the material source used and mining plan submitted. If the Contractor fails to perform the required mining area restoration prior to project completion, the CBJ may hire outside forces to perform the WORK and deduct the cost from this contingent sum item.
- D. Release of final payment for Mining Area Restoration and Road Cleaning Guarantee will be made upon determination of completeness by the ENGINEER after deduction of OWNER incurred costs for necessary road cleaning and/or mining area restoration not completed in a timely manner by the CONTRACTOR.
- E. Payment for Mining Area Restoration and Road Cleaning Guarantee will be made at the amount named in the Bid Schedule under Pay Item No. 2202.3, which payment will constitute full compensation for all WORK described in Section 2202 – Excavation and Embankment, as shown on the Drawings and as directed by the ENGINEER.

### 2.5 2-INCH MINUS SHOT ROCK w/ BASE COURSE (Pay Item No. 2204.1) PRICE BASED ON QUANTITY, CUBIC YARD

- A. 2-Inch Minus Shot Rock w/ Base Course will be measured by the number of cubic yards of material in place as determined by the average end area method and will be determined on a neat line basis. Where impractical to measure by the average end area method, the ENGINEER may approve other acceptable methods involving three-dimensional measurements. Material outside of the lines, grades and cross sections indicated in the Drawings, or as directed by the ENGINEER, will be deducted from 2-Inch Minus Shot Rock w/ Base Course quantities for pay purposes.
- B. Base Course, Grading D-1, may be used under the driveways, sidewalk and curb as a substitute for 2-Inch Minus Shot Rock w/ Base Course as a no cost change. This material will be measured for payment under this Pay Item.
- C. Water needed for compaction and added to the base material on the grade will be considered incidental.
- D. 2-Inch Minus Shot Rock will be placed and compacted into a layer 7-½-inches to 8-½-inches thick, and covered with Base Course, for a total thickness of 9-½-inches for the area under the roadway pavement and asphalt driveway limits as shown in the Drawings. Both of these materials will be measured for payment under this Pay Item. 2-Inch Minus Shot Rock shall meet the requirements of Section 2202 – Excavation and Embankment.
- E. 2-Inch Minus Shot Rock will be placed and compacted into a layer 4-inches to 5-inches thick, and covered with Base Course, for a total thickness of 6-inches under asphalt sidewalks as shown in the Drawings. Both of these materials will be measured for payment under this Pay Item. 2-Inch Minus Shot Rock shall meet the requirements of Section 2202 – Excavation and Embankment.

## SPECIAL PROVISIONS

- F. Payment for 2-Inch Minus Shot Rock w/ Base Course will be made at the Unit Price named in the Bid Schedule under Pay Item No. 2204.1, which payment will constitute full compensation for all WORK described in Section 02204 – Base Course, as shown on the Drawings and as directed by the ENGINEER.

### 2.6 BASE COURSE, GRADING D-1 FOR DRIVEWAYS (Pay Item No. 2204.2) PRICE BASED ON QUANTITY, TON

- A. Base Course Grading D-1 for existing gravel driveways and fire hydrant pads shall be measured by the ton delivered and placed in accordance with these Specifications. Said measurement may include moisture up to a maximum of 7.0% of dry weight of the material.
- B. When check tests by the ENGINEER indicate that moisture content in excess of 7.0% may be occurring, the frequency of testing will be increased as necessary and the results averaged. When this average tested moisture content is greater than 7.0%, the tonnage, as measured over the period tested, shall be reduced by a percentage equal to the difference between the actual moisture content and 7.0%. No credit will be due the CONTRACTOR when moisture content is less than 7.0%. Samples for determination of moisture content shall be collected at the point of weighing.
- C. Water needed for compaction and added to the base material on the grade will be considered incidental.
- D. Payment for Base Course, Grading D-1 for Driveways, will be made at the Unit Price named in the Bid Schedule under Pay Item No. 2204.2, which payment will constitute full compensation for all WORK described in Section 02204 – Base Course, as shown on the Drawings and as directed by the ENGINEER.

### 2.7 SANITARY SEWER PIPE, [ ]-INCH PVC (Pay Item Nos. 2401.1 and 2401.2) PRICE BASED ON QUANTITY, LINEAR FOOT

- A. Sanitary Sewer Pipe will be measured along the slope of the pipe in feet, from center to center of manholes, from center of manholes to end of pipe, or to limits of payment as shown on the Drawings. The aggregate laid lengths of wyes will not be deducted from lengths of pipes so measured.
- B. Any lengths of C900 pipe installed at sewer/water crossings (per CBJ Standard Detail 215) will be paid for at the unit price for Sanitary Sewer Pipe, 8-Inch PVC, under Pay Item No. 2401.1.
- C. Trench excavation, bedding, backfill, imported backfill, warning tape, fittings, cleaning and testing will not be measured for payment, but will be considered incidental to the WORK.
- D. Payment for Sanitary Sewer Pipe, 8-Inch PVC will be made at the Unit Price named in the Bid Schedule under Pay Item No. 2401.1, which payment will constitute full compensation for all WORK described in Section 2401 – Sanitary Sewer Pipe, as shown on the Drawings and as directed by the ENGINEER.
- E. Payment for Sanitary Sewer Pipe, 12-Inch PVC will be made at the Unit Price named in the Bid Schedule under Pay Item No. 2401.2, which payment will constitute full compensation

## SPECIAL PROVISIONS

for all WORK described in Section 2401 – Sanitary Sewer Pipe, as shown on the Drawings and as directed by the ENGINEER.

2.8 SERVICE CONNECTIONS AND LATERALS (Pay Item No. 2401.3) PRICE BASED ON QUANTITY, EACH

- A. Service Connections and Laterals 6-inches and smaller will be measured per each, complete in place, including pipe, wyes, cleanouts and ductile iron or cast iron frame and cover, with “SEWER” cast on it, fittings, and adapters, as required to connect to mainline sewer or connect to manhole, trench excavation, bedding, backfill, sewer warning tape, trench shoring and bracing, dewatering, cleaning and testing, and all other items necessary for a complete installation.
- B. The determination of the connection point to the existing service pipe will be made by the ENGINEER at the time the existing service pipe has been exposed to view. The CONTRACTOR shall proceed with trenching towards the residence until the ENGINEER has determined a suitable connection point is reached.
- C. Payment for Sewer Connections and Laterals will be made at the Unit Price named in the Bid Schedule under Pay Item No. 2401.3, which payment will constitute full compensation for all WORK described in Section 2401 – Sanitary Sewer Pipe, as shown on the Drawings and as directed by the ENGINEER.

2.9 LOCATE SANITARY SEWER SERVICES (Pay Item No. 2401.4) PRICE BASED ON LUMP SUM PAY UNIT

- A. Measurement for payment for Locate Sanitary Sewer Services will be based upon the completion of the entire WORK as a Lump Sum Pay Unit, complete, all in accordance with the requirements of the Contract Documents.
- B. The WORK under this Pay Item includes all excavation and backfill, and other WORK necessary to determine the location of all existing sanitary sewer services prior to installation of the new sewer services. Elevation checks shall be made with the new water and storm drain piping to determine if pipe conflicts exist. If pipe conflicts exist, data shall be submitted to the ENGINEER so that a solution can be provided to the Contractor. The WORK also includes field confirming sewer laterals are not active prior to abandoning, as shown on the Drawings.
- C. Payment for Locate Sanitary Sewer Services will be made at the amount named in the Bid Schedule under Pay Item No. 2401.4, which payment will constitute full compensation for all WORK described in Section 02401 – Sanitary Sewer Pipe, as shown on the Drawings and as directed by the ENGINEER.

2.10 CONNECT TO EXISTING SANITARY SEWER PIPE (Pay Item No. 2401.5) PRICE BASED ON QUANTITY, EACH

- A. Connect to Existing Sanitary Sewer Pipe will be measured per each, complete in place, including excavation, bedding, backfill, sheeting and bracing, dewatering, cleaning, pipe, LSS-1 clamp coupling, fittings, and adapters as required to connect the new sanitary sewer main to the existing sewer main in the locations shown on the Drawings and in accordance with the Contract Documents.

## SPECIAL PROVISIONS

- B. Payment for Connect to Existing Sanitary Sewer Pipe will be made at the Unit Price named in the Bid Schedule under Pay Item No. 2401.5, which payment will constitute full compensation for all WORK described in Section 2401 – Sanitary Sewer Pipe, as shown on the Drawings and as directed by the ENGINEER.
- 2.11 SANITARY SEWER MANHOLE, TYPE I WITH FIBERGLASS BASE LINER (Pay Item No. 2402.1) PRICE BASED ON QUANTITY, EACH
- A. Sanitary Sewer Manholes with Fiberglass Base Liner will be measured per each, complete in place, including all earthwork, 24-inch thick 2" minus shot rock pad, waterproofing, frame and lid assembly, Infra-Riser adjustment rings, temporary sewer bypass, Kor-N-Seal connectors, fiberglass base liner, and transition slab with asphalt pavement overlay, if required.
- B. All WORK required to reset the frame and cover to grade if not installed to proper grade tolerances during paving operations, including construction of a concrete transition slab with pavement overlay, if necessary, will be considered incidental to other work under this Contract.
- C. Payment for Sanitary Sewer Manhole, Type I with Fiberglass Base Liner will be made at the Unit Price named in the Bid Schedule under Pay Item No. 2402.1, which payment will constitute full compensation for all WORK described in Section 02402 – Sanitary Sewer Manholes and Cleanouts, as shown on the Drawings and as directed by the ENGINEER.
- 2.12 [ ]-INCH PIPE CULVERT (Pay Item Nos. 2501.1, 2501.2, 2501.3 and 2501.4) PRICE BASED ON QUANTITY, LINEAR FOOT
- A. Culvert Pipes, including all coupling bands, bends and other items necessary for the proper joining of the culvert pipe sections, will be measured by the staked length in linear feet.
- B. Pipes for storm drains shall be measured by the staked length, from center to center of structures or to ends of pipe if no structure is present. No deduction shall be made for footage through inlets, catch basins, or manholes.
- C. Branch connections, coupling adapters and bends will be included in the linear foot measurement for conduit.
- D. Trench excavation, bedding, backfill, imported backfill, capping and marking ends of PVC storm service pipes and warning tape will not be measured for payment, but will be considered incidental to other WORK.
- E. Payment for 4 and 6-Inch Pipe Culvert will be made at the Unit Price named in the Bid Schedule under Pay Item No. 2501.1, which payment will constitute full compensation for all WORK described in Section 02501 – Storm Sewer Pipe, as shown on the Drawings and as directed by the ENGINEER.
- F. Payment for 12-Inch Pipe Culvert will be made at the Unit Price named in the Bid Schedule under Pay Item No. 2501.2, which payment will constitute full compensation for all WORK described in Section 02501 – Storm Sewer Pipe, as shown on the Drawings and as directed by the ENGINEER.

## SPECIAL PROVISIONS

- G. Payment for 18-Inch Pipe Culvert will be made at the Unit Price named in the Bid Schedule under Pay Item No. 2501.3, which payment will constitute full compensation for all WORK described in Section 02501 – Storm Sewer Pipe, as shown on the Drawings and as directed by the ENGINEER.
  - H. Payment for 24-Inch Pipe Culvert will be made at the Unit Price named in the Bid Schedule under Pay Item No. 2501.4, which payment will constitute full compensation for all WORK described in Section 02501 – Storm Sewer Pipe, as shown on the Drawings and as directed by the ENGINEER.
- 2.13 6-INCH UNDERDRAIN (Pay Item No. 2501.5) PRICE BASED ON QUANTITY, LINEAR FOOT
- A. Underdrain pipe, including all coupling bands and other items necessary for the proper joining of the pipe sections, will be measured by the staked length.
  - B. Underdrain pipe will be measured from center of structures or ends of pipe, as shown on the Drawings, or as directed by the ENGINEER.
  - C. Pipe perforations, clean 2-inch minus shot rock, filter cloth, and cleanouts as shown on the Drawings will not be measured for payment but will be considered incidental to other WORK.
  - D. Excavation, bedding and backfill will not be measured for payment, but will be considered incidental to other WORK.
  - E. Payment for 6-Inch Underdrain will be made at the Unit Price named in the Bid Schedule under Pay Item No. 2501.5, which payment constitutes full compensation for all WORK described in Section 02501 – Storm Sewer Pipe, as shown on the Drawings and as directed by the ENGINEER.
- 2.14 CPP SADDLE TEE (Pay Item No. 2501.6) PRICE BASED ON QUANTITY, EACH
- A. CPP Saddle Tees or Fabricated CPP Tees will be measured per each, complete in place, regardless of size.
  - B. The WORK under this Pay Item will include those CPP Saddle Tees or Fabricated CPP Tees as shown on the Drawings, and also will be used to connect to the storm drain mains at locations as required to intercept unknown underground drainage pipes and flows.
  - C. Only those CPP Saddle Tees or Fabricated CPP Tees actually required, as shown on the Drawings, and as determined by the ENGINEER, will be measured for payment.
  - D. Payment for CPP Saddle Tee will be made at the Unit Price named in the Bid Schedule under Pay Item No. 2501.6, which payment will constitute full compensation for all WORK described in Section 02501 – Storm Sewer Pipe, as shown on the Drawings and as directed by the ENGINEER.
- 2.15 STORM DRAIN MANHOLE, TYPE [ ] (Pay Item Nos. 2502.1 and 2502.2) PRICE BASED ON QUANTITY, EACH

## SPECIAL PROVISIONS

- A. Storm Drain Manholes will be measured per each, complete in place, including all earthwork, 24-inch thick 2" minus shot rock pad, dewatering, bedding, backfill, imported backfill, grouting, frames and grates or covers, as shown on the Drawings.
  - B. Payment for Storm Drain Manhole, Type I will be made at the Unit Price named in the Bid Schedule under Pay Item No. 2502.1, which payment will constitute full compensation for all WORK described in Section 02502 – Storm Sewer Manholes, Inlets and Catch Basins, as shown on the Drawings and as directed by the ENGINEER.
  - C. Payment for Storm Drain Manhole, Type II will be made at the Unit Price named in the Bid Schedule under Pay Item No. 2502.2, which payment will constitute full compensation for all WORK described in Section 02502 – Storm Sewer Manholes, Inlets and Catch Basins, as shown on the Drawings and as directed by the ENGINEER.
- 2.16 CATCH BASIN, TYPE [ ] (Pay Item Nos. 2502.3 and 2502.4) PRICE BASED ON QUANTITY, EACH
- A. Catch Basins will be measured per each, complete in place, including all earthwork, 24-inch thick 2" minus shot rock pad, dewatering, bedding, backfill, imported backfill, grouting, frames and grates or covers, as shown on the Drawings.
  - B. Payment for Catch Basin, Type IV will be made at the Unit Price named in the Bid Schedule under Pay Item No. 2502.3, which payment will constitute full compensation for all WORK described in Section 02502 – Storm Sewer Manholes, Inlets and Catch Basins, as shown on the Drawings and as directed by the ENGINEER.
  - C. Payment for Catch Basin, Type III will be made at the Unit Price named in the Bid Schedule under Pay Item No. 2502.4, which payment will constitute full compensation for all WORK described in Section 02502 – Storm Sewer Manholes, Inlets and Catch Basins, as shown on the Drawings and as directed by the ENGINEER.
- 2.17 24-INCH CPP INLET (Pay Item No. 2502.5) PRICE BASED ON QUANTITY, EACH
- A. 24-Inch CPP Inlet will be measured per each, complete in place, including all earthwork, dewatering, bedding, backfill, imported backfill, frames and grates, as shown on the Drawings.
  - B. Payment for 24-Inch CPP Inlet will be made at the Unit Price named in the Bid Schedule under Pay Item No. 2502.5, which payment will constitute full compensation for all WORK described in Section 02502 – Storm Sewer Manholes, Inlets and Catch Basins, as shown on the Drawings and as directed by the ENGINEER.
- 2.18 CONNECT TO DISSIMILAR STORM DRAIN PIPE (Pay Item No. 2502.6) PRICE BASED ON QUANTITY, EACH
- A. Connect to Dissimilar Storm Drain Pipe will be measured per each, complete in place, all in accordance with the requirements of the Contract Documents.
  - B. Payment for Connect to Dissimilar Storm Drain Pipe will be made at the amount named in the Bid Schedule under Pay Item No. 2502.7, which payment will constitute full

## SPECIAL PROVISIONS

compensation for all WORK described in Section 02502 – Storm Sewer Manholes, Inlets and Catch Basins, as shown on the Drawings and as directed by the ENGINEER.

- 2.19 [ ]-INCH HDPE WATER PIPE (Pay Item Nos. 2601.1 and 2601.2) PRICE BASED ON QUANTITY, LINEAR FOOT
- A. Measurement of water pipe will be made along the slope of the HDPE pipe from center of HDPE fittings and valves in linear feet. No deduction in length will be made for valves, fittings, or HDPE fused reducers. No measurement for payment will be made for any ductile iron water pipe used to make up the overall connection, only HDPE water pipe will be measured for payment. All fittings, other than valves, required for satisfactory installation of water pipe will be considered incidental to the HDPE water pipe pay items.
  - B. All trench excavation, bedding, backfill, cleaning, disinfection and pressure testing, concrete thrust blocks, warning tape, tracer wire, and all other items necessary for a complete installation will not be measured for payment, but will be considered incidental to other WORK.
  - C. Payment for 10-Inch HDPE Water Pipe will be made at the Unit Price named in the Bid Schedule under Pay Item No. 2601.1, which payment will constitute full compensation for all WORK described in Section 02601 - Water Pipe, as shown on the Drawings and as directed by the ENGINEER.
  - D. Payment for 24-Inch HDPE Water Pipe will be made at the Unit Price named in the Bid Schedule under Pay Item No. 2601.2, which payment will constitute full compensation for all WORK described in Section 02601 - Water Pipe, as shown on the Drawings and as directed by the ENGINEER.
- 2.20 CONNECT TO EXISTING WATER PIPE (Pay Item No. 2601.3) PRICE BASED ON QUANTITY, EACH
- A. Measurement for payment of Connect to Existing Water Pipe will be based on the actual quantity, each, of such connections made to existing water pipe installed in accordance with the requirements of the Contract Documents.
  - B. The WORK under this Pay Item includes all excavation and backfill, cutting and removing sections of existing water pipe, and all materials including new couplers, bands, fittings, ductile iron water pipe, joint restraints, and all other WORK and materials necessary to complete connections of new ductile iron water pipe to existing ductile iron water pipes.
  - C. Payment for Connect to Existing Water Pipe will be made at the amount named in the Bid Schedule under Pay Item No. 2601.3, which payment will constitute full compensation for all WORK described in Section 02601 – Water Pipe, as shown on the Drawings and as directed by the ENGINEER.
- 2.21 TEMPORARY WATER SYSTEM (Pay Item No. 2601.4) PRICE BASED ON LUMP SUM PAY UNIT
- A. Measurement for payment for Temporary Water System will be based upon the completion of the entire WORK as a Lump Sum Pay Unit, complete, all in accordance with the requirements of the Contract Documents.

## SPECIAL PROVISIONS

- B. All piping, valves, fittings, joint restraints, excavation, bedding, backfill, disinfection, testing, and all other items of WORK necessary for complete installation of a temporary water system will not be measured for payment, but will be considered incidental to this Pay Item.
- C. The existing Tongass Boulevard water main is the primary fill line for the East Valley reservoir located at the end of Dudley Street. Special requirements are identified in the Contract Documents regarding water main shutdowns and temporary water systems, which will be considered incidental to this Pay Item.
- D. Payment for Temporary Water System will be made at the Unit Price named in the Bid Schedule under Pay Item No. 2601.4, which payment will constitute full compensation for all WORK described in Section 02601 – Water Pipe, as shown on the Drawings and as directed by the ENGINEER.

### 2.22 CORROSION PROTECTION (Pay Item No. 2601.5) PRICE BASED ON QUANTITY, EACH

- A. Measurement for payment for Corrosion Protection will be the actual number of anodes satisfactorily installed as shown on the Drawings.
- B. Installation of corrosion protection includes all material, labor, and other WORK as described and shown on the Drawings, including at fire hydrant legs.
- C. Excavation and backfill will not be measured for payment but will be considered incidental to the WORK.
- D. Payment for Corrosion Protection will be made at the Unit Price named in the Bid Schedule under Pay Item No. 2601.5, which payment will constitute full compensation for all WORK described in Section 02601 – Water Pipe, as shown on the Drawings and as directed by the ENGINEER.

### 2.23 10-INCH GATE VALVE (Pay Item No. 2602.1) PRICE BASED ON QUANTITY, EACH

- A. Measurement for payment of 10-Inch Gate Valves will be based on the actual quantity, each, of such valves and valve boxes furnished and installed in accordance with the requirements of the Contract Documents.
- B. All WORK required to reset the valve box and lid to grade if not installed to proper grade tolerances during paving operations, including construction of a concrete transition slab with pavement overlay (per CBJ Standard Detail 126 – Concrete Collar), will be considered incidental to other work under this Contract.
- C. Payment for 10-Inch Gate Valve will be made at the Unit Price named in the Bid Schedule under Pay Item No. 2602.1, which payment will constitute full compensation for all WORK described in Section 02602 – Valves, as shown on the Drawings and as directed by the ENGINEER.



## SPECIAL PROVISIONS

### 2.24 24-INCH BUTTERFLY VALVE (Pay Item No. 2602.2) PRICE BASED ON QUANTITY, EACH

- A. Measurement for payment of 24-Inch Butterfly Valve will be based on the actual quantity, each, of such valves and valve boxes furnished and installed in accordance with the requirements of the Contract Documents.
- B. All WORK required to reset the valve box and lid to grade if not installed to proper grade tolerances during paving operations, including construction of a concrete transition slab with pavement overlay (per CBJ Standard Detail 126 – Concrete Collar), will be considered incidental to other work under this Contract.
- C. Payment for 24-Inch Butterfly Valve will be made at the Unit Price named in the Bid Schedule under Pay Item No. 2602.2, which payment will constitute full compensation for all WORK described in Section 02602 – Valves, as shown on the Drawings and as directed by the ENGINEER.

### 2.25 FIRE HYDRANT ASSEMBLY WITH ACCESS PAD (Pay Item No. 2603.1) PRICE BASED ON QUANTITY, EACH

- A. Measurement for payment of Fire Hydrant Assembly with Access Pad will be the actual number of fire hydrant assemblies satisfactorily installed, complete in place.
- B. A Fire Hydrant Assembly includes the fire hydrant, the tee or required fitting at the mainline water pipe, thrust block, 8-inch HDPE water leg from the main to the gate valve (including the 8x6 reducer at the gate valve) barrel extension (if required), thrust block, six-inch gate valve, valve box, adjustment of valve box, installation of fire hydrant guard posts, 6-inch DI pipe from the gate valve to the barrel, joint restraints, tracer wires, trace wire splice connectors, warning tape, hydrant flag, hydrant drain plug, and any other required fittings, including pipe to connect the hydrant leg from the mainline water pipe to the fire hydrant or from the stubbed water pipe to the fire hydrant as shown on the Drawings.
- C. Hydrant access pad shall include all excavation, backfill, and sideslope grading. Base course grading D-1 will be paid for under Pay Item No. 2204.2, Base Course Grading D-1.
- D. Asphalt for hydrant access pad shall be paid for under Pay Item No. 2801.2, A.C. Pavement for Sidewalks, Driveways and Hydrant Pads.
- E. Payment for Fire Hydrant Assembly with Access Pad will be made at the Unit Price named in the Bid Schedule under Pay Item No. 2603.1 which payment shall constitute full compensation for all WORK described in Section 02603 – Fire Hydrants, as shown on the Drawings and as directed by the ENGINEER.

### 2.26 AIR RELEASE VALVE (Pay Item No. 2604.1) PRICE BASED ON QUANTITY, EACH

- A. Measurement for payment of Air Release Valve will be the actual number of Air Release Valves satisfactorily installed, complete in place.
- B. Work under this Pay Item includes the removal and disposal of existing air release valve assembly, removal and disposal of existing concrete manhole structure and lid, removal and disposal of existing air release drain pipe, and removal and disposal of existing insulation.

## SPECIAL PROVISIONS

- C. Work under this Pay Item includes furnishing and installing precast concrete manhole structure with ladder rungs, air release valve, curb stop, corporation stop, service saddle, pipe, fittings, air release vault drain, insulated cover, water proof connection, all earthwork and all other work to make a satisfactory installation as shown on the Standard Drawings.
  - D. Payment for Air Release Valve will be made at the Unit Price named in the Bid Schedule under Pay Item No. 2604.1, which payment shall constitute full compensation for all WORK described in Section 02604 – Air Release Valve, as shown on the Drawings and as directed by the ENGINEER.
- 2.27 1-INCH POLY WATER SERVICES (Pay Item No. 2605.1) PRICE BASED ON QUANTITY, EACH
- A. Measurement for payment for 1-Inch Poly Water Services will be the actual number of water services satisfactorily installed from the water main to the property line or tie in location as shown on the Drawings, and as directed by the Engineer.
  - B. A water service includes the curb stop, service box, corporation stop, trace wires, trace wire splice connectors, service saddle, all required fittings, warning tape, water service pipe, connecting to existing water service pipe, and all WORK necessary to install the water service to the locations shown on the Drawings.
  - C. Trench excavation, bedding, backfill, flushing, disinfection and pressure testing shall be considered incidental to the water service installation.
  - D. Payment for 1-Inch Poly Water Service will be made at the Unit Price named in the Bid Schedule under Pay Item No. 2605.1, which payment will constitute full compensation for all WORK described in Section 02605 – Water Services, as shown on the Drawings and as directed by the ENGINEER.
- 2.28 4-INCH HDPE WATER SERVICES (Pay Item No. 2605.2) PRICE BASED ON QUANTITY, EACH
- A. Measurement for payment for 4-Inch HDPE Water Services will be the actual number of water services satisfactorily installed from the water main to the property line or tie in location as shown on the Drawings, and as directed by the Engineer.
  - B. A water service includes the 4-inch gate valve, valve box, trace wires, trace wire splice connectors, HDPE tee fitting, all required fittings, warning tape, water service pipe, connecting to existing water service pipe, and all WORK necessary to install the water service to the locations shown on the Drawings.
  - C. Trench excavation, bedding, backfill, flushing, disinfection and pressure testing shall be considered incidental to the water service installation.
  - D. Payment for 4-Inch HDPE Water Services will be made at the Unit Price named in the Bid Schedule under Pay Item No. 2605.2, which payment will constitute full compensation for all WORK described in Section 02605 – Water Services, as shown on the Drawings and as directed by the ENGINEER.

## SPECIAL PROVISIONS

- 2.29 LOCATE WATER SERVICES (Pay Item No. 2605.3) PRICE BASED ON LUMP SUM PAY UNIT
- A. Measurement for payment for Locate Water Services will be based upon the completion of the entire WORK as a Lump Sum Pay Unit, complete, all in accordance with the requirements of the Contract Documents.
  - B. The WORK under this Pay Item includes all excavation, backfill and other WORK required to locate and expose existing water service valve boxes and locating the existing water services so that connections to new water services can be made. Some existing water service boxes have not been field located due to limited as-built information. Some service locations shown on the Drawings are assumed and should be field confirmed by the CONTRACTOR.
  - C. Payment for Locate Water Services will be made at the amount named in the Bid Schedule under Pay Item No. 2605.3, which payment will constitute full compensation for all WORK described in Section 02605 – Water Services, as shown on the Drawings and as directed by the ENGINEER.
- 2.30 PIPE INSULATION (Pay Item No. 2607.1) PRICE BASED ON QUANTITY, BOARD
- A. Measurement for payment of Pipe Insulation will be the actual number of 2" x 2' x 8' boards installed.
  - B. Pipe insulation shall only be installed as directed by the ENGINEER. Only those boards of pipe insulation approved by the ENGINEER to be installed will be measured for payment.
  - C. Payment for Pipe Insulation will be made at the Unit Price named in the Bid Schedule under Pay Item No. 2607.1, which payment will constitute full compensation for all WORK described in Section 02607 – Pipe Insulation, as shown on the Drawings and as directed by the ENGINEER.
- 2.31 CONSTRUCTION SURVEYING (Pay Item No. 2702.1) PRICE BASED ON LUMP SUM PAY UNIT
- A. Measurement for payment of Construction Surveying will be based upon the completion of the entire WORK as a Lump Sum Pay Unit, complete, all in accordance with the requirements of the Contract Documents.
  - B. The WORK required to remove and reset all existing survey monuments, monument cases, and other survey markers disturbed by construction activities, whether shown on the Drawings or not, will be considered incidental to other WORK.
  - C. Payment for Construction Surveying will be made at the Unit Price named in the Bid Schedule under Pay Item No. 2702.1, which payment will constitute full compensation for all WORK described in Section 02702 – Construction Surveying, as shown on the Drawings and as directed by the ENGINEER.
- 2.32 REMOVE AND RESET CHAIN LINK FENCE (Pay Item No. 2707.1) PRICE BASED ON QUANTITY, LINEAR FOOT
- A. Measurement for payment of Remove and Reset Chain Link Fence will be measured per linear foot along the face of the reset fence complete in place and accepted.

## SPECIAL PROVISIONS

- B. The WORK for this Pay Item includes removing, salvaging, and reinstalling existing chain link fence fabric on new chain link fence posts with new fence concrete footings and all required fencing connection hardware in locations as shown on the Drawings. The WORK includes removal and disposal of existing chain link fence posts and footings. WORK shall include all materials, labor and equipment necessary to make a complete and satisfactory installation.
  - C. Payment for Remove and Reset Chain Link Fence will be made at the Unit Price named in the Bid Schedule under Pay Item No. 2707.1, which payment will constitute full compensation for all WORK described in Section 02707 – Chain Link Fence, as shown on the Drawings and as directed by the ENGINEER.
- 2.33 REMOVE AND RESET WOOD FENCE (Pay Item No. 2707.2) PRICE BASED ON QUANTITY, LINEAR FOOT
- A. Measurement for payment of Remove and Reset Wood Fence will be measured per linear foot along the face of the fence, complete in place and accepted.
  - B. The WORK for this Pay Item includes salvaging existing wood fence vertical and horizontal slat boards and fence railing boards, removing and disposing of existing wood fence posts and concrete footings, setting new wood fence posts in concrete footing, reassembling the salvaged wood fence materials and all other necessary fence hardware to make a complete and satisfactory fence installation.
  - C. Excavation, grading, painting or staining wood materials to match existing fence shall be considered incidental to the fence installation.
  - D. Payment for Remove and Reset Wooden Fence will be made at the Unit Price named in the Bid Schedule under Pay Item No. 2707.2, which payment will constitute full compensation for all WORK described in Section 02707 – Chain Link Fence, as shown on the Drawings and as directed by the ENGINEER.
- 2.34 TOPSOIL (Pay Item No. 2709.1) PRICE BASED ON QUANTITY, CUBIC YARD
- A. Measurement for payment of Topsoil will be by the cubic yard on the basis of truck measure for all WORK performed in the Contract under Section 02709 – Topsoil, completed and accepted.
  - B. Topsoil found to be in excess of 3-inches thick, in place and to final grade, will be deducted from the quantity measured by truck measure based on depths measured at randomly selected locations. Deductions will be computed based on the average end area method.
  - C. Payment for Topsoil will be made at the Unit Price named in the Bid Schedule under Pay Item No. 2709.1, which payment will constitute full compensation for all WORK described in Section 02709 – Topsoil, as shown on the Drawings and as directed by the ENGINEER.

## SPECIAL PROVISIONS

- 2.35 TOPSOIL FINISH GRADING (Pay Item No. 2709.2) PRICE BASED ON QUANTITY, MAN-HOUR
- A. Topsoil Finish Grading will be measured per man-hour for each man-hour, or part thereof, that the labor personnel is actually at the project site working as directed by the ENGINEER. No measurement for payment will be made for any man-hours not actually working on the finish grading of the topsoil as directed, including travel time, materials and tools expediting, or supervisory personnel.
  - B. No measurement for Topsoil Finish Grading will be made until the topsoil has been graded to a uniform appearance and to within the tolerances required under Pay Item No. 2709.1, Topsoil. Topsoil Finish Grading will only be required when requested by the ENGINEER.
  - C. Payment for Topsoil Finish Grading will be made at the Unit Price named in the Bid Schedule under Pay Item No. 2709.2, which payment will constitute full compensation for all WORK described in Section 02709 - Topsoil, as shown on the Drawings and as directed by the ENGINEER.
- 2.36 SEEDING, HYDRAULIC METHOD, TYPE III (Pay Item No. 2710.1) PRICE BASED ON QUANTITY, SLURRY UNIT
- A. Seeding by the hydraulic method will be measured for payment by the number of slurry units (to the nearest 1/10 unit) of mixture actually applied to the designated area as shown on the Drawings and directed by the ENGINEER.
  - B. Payment for Seeding, Hydraulic Method, Type III will be made at the Unit Price named in the Bid Schedule under Pay Item No. 2710.1, which payment will constitute full compensation for all WORK described in Section 02710 – Seeding, as shown on the Drawings and as directed by the ENGINEER.
- 2.37 REMOVE AND DISPOSE OF STORM AND SANITARY SEWER PIPE (Pay Item No. 2716.1) PRICE BASED ON LUMP SUM PAY UNIT
- A. Measurement for payment for Remove and Dispose of Storm and Sanitary Sewer Pipe will be based upon the completion of the entire WORK as a Lump Sum Pay Unit, complete, all in accordance with the requirements of the Contract Documents.
  - B. Filling of pipes to be abandoned with concrete slurry where pipe removal is not practical shall be considered incidental to this Pay Item.
  - C. Payment for Remove and Dispose of Storm and Sanitary Sewer Pipe will be made at the Unit Price named in the Bid Schedule under Pay Item No. 2716.1, which payment will constitute full compensation for all WORK described in Section 02716 – Storm and Sanitary Sewer Pipe Removal and Water Pipe Slurry, as shown on the Drawings and as directed by the ENGINEER.

## SPECIAL PROVISIONS

- 2.38 FILL WATER PIPE WITH SLURRY (Pay Item No. 2716.2) PRICE BASED ON LUMP SUM PAY UNIT
- A. Measurement for payment for Fill Water Pipe with Slurry will be based upon the completion of the entire WORK as a Lump Sum Pay Unit, complete, all in accordance with the requirements of the Contract Documents.
  - B. The WORK under this pay item includes removal and disposal of existing water pipe, water service pipe, water service curb stops, main line valves and main line valve boxes as well as removal and disposal of existing fire hydrants, fire hydrant valves, fire hydrant pipe, protection bollards and footings, thrust blocks, pipe fittings, and other features shown in the Drawings or directed by the ENGINEER.
  - C. The WORK under this pay item also includes removing sections of water pipe or adding pipe as necessary to completely fill with slurry any existing water pipe, 4-inches in diameter and larger, that is to be abandoned in place.
  - D. Payment for Fill Water Pipe with Slurry will be made at the amount named in the Bid Schedule under Pay Item No. 2716.2, which payment will constitute full compensation for all WORK described in Section 02716 – Storm and Sanitary Sewer Pipe Removal and Water Pipe Slurry, as shown on the Drawings and as directed by the ENGINEER.
- 2.39 REMOVE AND DISPOSE OF STORM AND SANITARY SEWER STRUCTURES (Pay Item No. 2717.1) PRICE BASED ON LUMP SUM PAY UNIT
- A. Measurement for payment for Remove and Dispose of Storm and Sanitary Sewer Structures will be based upon the completion of the entire WORK as a Lump Sum Pay Unit, complete, all in accordance with the requirements of the Contract Documents.
  - B. Payment for Remove and Dispose of Storm and Sanitary Sewer Structures will be made at the Unit Price named in the Bid Schedule under Pay Item No. 2717.1, which payment will constitute full compensation for all WORK described in Section 2717 – Storm and Sanitary Structure Removal, as shown on the Drawings, and as directed by the ENGINEER.
- 2.40 SIGN ASSEMBLY (Pay Item No. 2718.1) PRICE BASED ON QUANTITY, EACH
- A. Sign Assemblies will be measured per each, as described in Section 02718 – Sign Assembly, and as shown in the Sign Assembly Table on the Drawings.
  - B. WORK under this Pay Item includes providing all new sign assembly materials, except as noted in the Sign Assembly Table on the Drawings.
  - C. Removal and disposal of existing sign posts and hardware not to be reused, and salvage and delivery of existing sign panels to CBJ, as indicated on the Drawings, will be considered incidental to other WORK under this Section.
  - D. Payment for Sign Assembly will be made at the Unit Price named in the Bid Schedule under Pay Item No. 2718.1, which payment will constitute full compensation for all WORK described in Section 02718 – Sign Assembly, as shown on the Drawings and as directed by the ENGINEER.

## SPECIAL PROVISIONS

### 2.41 RECONSTRUCT MAILBOX (Pay Item No. 2719.1) PRICE BASED ON QUANTITY, EACH

- A. Measurement for payment for Reconstruct Mailbox will be the actual number of mailboxes satisfactorily removed, reconstructed and relocated, as shown on the Drawings, CBJ Standard Details 116 and 117, and as directed by the ENGINEER.
- B. Mailboxes relocated, but not requiring reconstruction, as determined by the ENGINEER, will not be measured for payment, but will be considered incidental to other WORK under this Section.
- C. A gang-type mailbox constructed with two or more receptacles on one post assembly will be measured for payment as one unit. All clustered mailbox receptacles shall be constructed in pairs per CBJ Standard Detail 117, unless shown otherwise on the Drawings.
- D. Payment for Reconstruct Mailbox will be made at the Unit Price named in the Bid Schedule under Pay Item No. 2719.1, which payment will constitute full compensation for all WORK described in Section 02719 – Mailboxes, as shown on the Drawings, CBJ Standard Details 116 and 117, and as directed by the ENGINEER.

### 2.42 PAINTED TRAFFIC MARKINGS (Pay Item No. 2720.1) PRICE BASED ON LUMP SUM

- A. Measurement for payment for Painted Traffic Markings will be based upon the completion of the entire WORK as a Lump Sum Pay Unit, complete, all in accordance with the requirements of the Contract Documents.
- B. WORK under this Pay Item includes all crosswalk striping, fog lines, and double yellow centerlines as shown on the Drawings.
- C. Payment for Painted Traffic Markings will be made at the amount shown in the Bid Schedule under Pay Item No. 2720.1, which payment will constitute full compensation for all WORK described in Section 02720 – Painted Traffic Markings, as shown on the Drawings and as directed by the ENGINEER.

### 2.43 RELOCATE ELECTRICAL CONDUCTOR (Pay Item No. 2722.1) PRICE BASED ON QUANTITY, EACH

- A. Measurement for payment for Relocate Electrical Conductor will be the actual number of power, telephone or cable television conductors or conduits actually relocated and functional, as described in Section 02722 – Electrical Utilities, and as directed by the ENGINEER.
- B. Only those power, telephone or cable television conductors or conduits actually found to be in direct conflict with storm drain pipe or other pipe and structures, and approved by the ENGINEER for relocation, will be measured for payment.
- C. WORK under this Pay Item will include all power, telephone, or cable television conductors or conduits three (3) inches or less in diameter.
- D. Electrical conductors that run along the pipe trench, and are not in direct conflict with the new pipe being installed, but require that they must be pulled aside to clear the trenching and pipe installation operations will be considered incidental to other WORK under the Contract.

## SPECIAL PROVISIONS

- E. All WORK necessary to install new storm drain pipe or other new utility pipe beneath an existing utility conduit or conductor, including those that are encased in concrete, which does not intersect the new pipe, will be considered incidental to other WORK.
- F. Payment for Relocate Electrical Conductor will be made at the Unit Price named in the Bid Schedule under Pay Item No. 2722.1, which payment will constitute full compensation for all WORK described in Section 02722 – Electrical Utilities, as shown on the Drawings and as directed by the ENGINEER.

2.44 REMOVE AND RELOCATE LANDSCAPING (Pay Item No. 2723.1) PRICE BASED ON LUMP SUM PAY UNIT

- A. Measurement for Remove and Relocate Landscaping will be based upon the completion of the entire WORK as a Lump Sum Pay Unit, complete, all in accordance with the requirements of the Contract documents.
- B. Only those landscaping items found to be in direct conflict with the construction improvements and as approved by the ENGINEER for removal and relocation, will be measured for payment.
- C. This WORK includes the removal and relocation of existing landscape plants, bushes, trees, planter boxes and rock gardens on the project that are found to conflict with the proposed WORK and as directed by the ENGINEER.
- D. The WORK also includes removing and resetting landscape boulders in front of Glacier Valley Elementary that are found to conflict with the proposed WORK.
- E. Payment for Remove and Relocate Landscaping will be made at the Unit Price named in the Bid Schedule under Pay Item No. 2723.1, which payment will constitute full compensation for all WORK described in Section 02723 – Remove and Relocate Landscaping, as shown on the Drawings and as described by the ENGINEER.

2.45 A.C. PAVEMENT, TYPE II-A, CLASS B (Pay Item No. 2801.1) PRICE BASED ON QUANTITY, TON

- A. Asphalt Concrete Pavement, Type II-A, Class B will be measured by the Ton. The WORK under this Pay Item includes all roadway paving including the intersection tie-ins.
- B. No measurement will be made for asphalt concrete pavement that exceeds 12% more than the neat line quantity, as determined by the nominal design thickness multiplied by the actual area paved, with a conversion factor of 119.0 lbs. per square yard per inch of thickness.
- C. All resealing of joints with existing pavement, including those resealed after the pavement has cooled to ambient temperatures, will not be measured for payment, but will be considered incidental to other WORK under this Section.
- D. Tack Coat applied to existing joint surfaces and along edge of gutters prior to placement of asphalt concrete pavement, will be considered incidental to other WORK under this Section.
- E. Asphalt Pavement required for reconstructed collars around manholes and water valves, if any, will be considered incidental to other WORK under this Section.



## SPECIAL PROVISIONS

- F. Payment under Pay Item No. 2801.1 may include deductions in the final price if, after asphalt laboratory testing, the asphalt pavement does not meet the required specification. Deductions are further described in Section 02801 – Asphalt Concrete Pavement, Part 3 – Execution, Article 3.13 Acceptance Sampling and Testing, Paragraph K.
- G. Payment for A.C. Pavement, Type II-A, Class B, will be made at the Unit Price named in the Bid Schedule under Pay Item No. 2801.1, which payment will constitute full compensation for all WORK described in Section 02801 - Asphalt Concrete Pavement, as shown on the Drawings and as directed by the ENGINEER.

2.46 A.C. PAVEMENT FOR SIDEWALKS, DRIVEWAYS AND HYDRANT PADS (Pay Item No. 2801.2) PRICE BASED ON QUANTITY, SQUARE YARDS

- A. Measurement for Asphalt Concrete Pavement for Sidewalks, Driveways and Hydrant Pads will be based on the actual Square Yards complete in place and accepted.
- B. Asphalt concrete pavement shall be Type II-A, Class B or Type III, Class B.
- C. No measurement will be made for asphalt concrete pavement for sidewalks that is placed outside of the design area as shown on the Plans and Drawings, unless approved by the ENGINEER.
- D. WORK under Pay Item No. 2801.2 includes all pavement placed outside the roadway for sidewalks, driveways and hydrant pads, as shown on the Drawings and as directed by the ENGINEER.
- E. All resealing of joints with existing pavement will not be measured for payment but will be considered incidental to other WORK under this Section.
- F. Payment for A.C. Pavement for Sidewalks, Driveways and Hydrant Pads will be made at the Unit Price named in the Bid Schedule under Pay Item No. 2801.2, which payment will constitute full compensation for all WORK described in Section 02801 – Asphalt Concrete Pavement, as shown on the Drawings and as directed by the ENGINEER.

2.47 REMOVE EXISTING ASPHALT SURFACING (Pay Item No. 2806.1) PRICE BASED ON QUANTITY, SQUARE YARD

- A. Removing Existing Asphalt Surfacing, including asphalt overlay, will be measured per square yard, complete, except that no measurement will be made for removing asphaltic surfacing less than one inch thick. Asphalt thickness is estimated to be 2-3 inches thick.
- B. Removal of existing asphalt surfacing will be measured per top surface area square yard, which will include full thickness of all layers of existing asphalt, including overlays and underlying pavement.
- C. Payment for Remove Existing Asphalt Surfacing will be made at the Unit Price named in the Bid Schedule under Pay Item No. 2806.1, which payment will constitute full compensation for all WORK described in Section 02806 – Remove Existing Asphalt Surfacing, as shown on the Drawings and as directed by the ENGINEER.

## SPECIAL PROVISIONS

- 3.1 CONCRETE AREA DRAINS (Pay Item No. 3302.1) PRICE BASED ON QUANTITY, EACH
- A. Concrete Area Drains will be measured per each, including all earthwork, complete in place.
  - B. Payment for Concrete Area Drains will be made at the Unit Price named in the Bid Schedule under Pay Item No. 3302.1, which payment will constitute full compensation for all WORK described in Section 03302 – Concrete Structures, as shown on the Drawings and as directed by the ENGINEER.
- 3.2 CONCRETE HEADWALL WITH HINGED TRASH RACK (Pay Item No. 3302.2) PRICE BASED ON QUANTITY, EACH
- A. Concrete Headwall with Hinged Trash Rack will be measured for payment per each, including all earthwork, complete in place.
  - B. Payment for Concrete Headwall with Hinged Trash Rack will be made at the Unit Price named in the Bid Schedule under Pay Item No. 3302.2, which payment will constitute full compensation for all WORK described in Section 03302 – Concrete Structures, as shown on the Drawings and as directed by the ENGINEER.
- 3.3 CONCRETE ACCESS PAD, 6-INCHES THICK WITH DETECTABLE TILES (Pay Item No. 3303.1) PRICE BASED ON QUANTITY, SQUARE YARD
- A. Measurement for payment for Concrete Access Pads, 6-Inches Thick with Detectable Tiles will be based on the actual Square Yards complete in place and accepted.
  - B. WORK under this Pay Item includes all earthwork, concrete for ramps and landings, and detectable tiles complete in place and accepted.
  - C. Payment for Concrete Access Pad, 6-Inches Thick with Detectable Tiles, will be made at the Unit Price named in the Bid Schedule under Pay Item No. 3303.1, which payment will constitute full compensation for all WORK described in Section 03303 – Sidewalk, Curb and Gutter, as shown on the Drawings and as directed by the ENGINEER.
- 3.4 CONCRETE SIDEWALK, 6-INCHES THICK (Pay Item No. 3303.2) PRICE BASED ON QUANTITY, SQUARE YARD
- A. Measurement of Concrete Sidewalk, 6-Inches Thick will be based on the actual square yards complete in place and accepted.
  - B. Payment for Concrete Sidewalk, 6-Inches Thick, will be made at the Unit Price named in the Bid Schedule under Pay Item No. 3303.2, which payment will constitute full compensation for all WORK described in Section 03303 – Sidewalk, Curb and Gutter, as shown on the Drawings and as directed by the ENGINEER.
- 3.5 CURB AND GUTTER, TYPE I (Pay Item No. 3303.3) PRICE BASED ON QUANTITY, LINEAR FOOT
- A. Curb and Gutter, Type I, will be measured per linear foot installed, complete in place as shown on the Contract Documents. Measurements will be made along the face of the curb and will be continuous across catch basins and storm drain manhole inlets.

## SPECIAL PROVISIONS

- B. Modified curb and gutter will be paid for under this Pay Item.
  - C. Payment for Curb and Gutter, Type I, will be made at the Unit Price named in the Bid Schedule under Pay Item No. 3303.3, which payment will constitute full compensation for all WORK described in Section 03303 - Sidewalk, Curb and Gutter, as shown on the Drawings, and as directed by the ENGINEER.
- 3.6 REMOVAL OF CONCRETE SIDEWALKS (Pay Item No. 3304.1) PRICE BASED ON QUANTITY, SQUARE YARD
- A. Removal of Concrete Sidewalks will be measured for payment by the actual square yards of concrete slab originally in place, removed and disposed of, in accordance with the Contract Documents.
  - B. Payment for Removal of Concrete Sidewalks will be made at the Unit Price named in the Bid Schedule under Pay Item No. 3304.1, which payment will constitute full compensation for all WORK described in Section 03304 – Remove Existing Sidewalk, Concrete Slab, or Curb and Gutter, as shown on the Drawings and as directed by the ENGINEER.
- 3.7 REMOVAL OF CURB AND GUTTER (Pay Item No. 3304.2) PRICE BASED ON QUANTITY, LINEAR FOOT
- A. Removal of Curb and Gutter will be measured for payment by the actual linear foot of concrete curb and gutter originally in place, removed and disposed of in accordance with the Contract Document.
  - B. Asphalt pavement found over concrete gutter will not be measured for payment but considered incidental to other items of WORK under this Section.
  - C. Payment for Removal of Curb and Gutter will be made at the Unit Price named in the Bid Schedule under Pay Item No. 3304.2, which payment will constitute full compensation for all WORK described in Section 03304 – Remove Existing Sidewalk, Concrete Slab, or Curb and Gutter, as shown on the Drawings and as directed by the ENGINEER.
- 26.0 LIGHTING (Pay Item No. 260000.1) PRICE BASED ON LUMP SUM PAY UNIT
- A. Measurement for payment for Lighting will be based upon the completion of the entire WORK as a Lump Sum Pay Unit, complete, all in accordance with the requirements of the Contract Documents.
  - B. WORK under this Pay Item includes the lighting as shown on the Drawings.
  - C. Payment for Lighting will be made at the amount shown in the Bid Schedule under Pay Item No. 260000.1, which payment will constitute full compensation for all WORK described in Section 260000 – General Electrical Requirements, Section 260519 – Low Voltage Electrical Power Conductors and Cables, Section 260526 – Grounding and Bonding for Electrical Systems, Section 260533 – Raceways and Boxes for Electrical Systems, Section 260553 – Identification for Electrical Systems, and Section 262713 – Electricity Metering, as shown on the Drawings and as directed by the ENGINEER.

## SPECIAL PROVISIONS

**PART 2 - PRODUCTS** (Not Used)

**PART 3 - EXECUTION** (Not Used)

### END OF SECTION

**SECTION 01550 – SITE ACCESS AND STORAGE, PART 1 – GENERAL, Article 1.3, MAINTENANCE OF TRAFFIC, *replace paragraph M and add paragraph U:***

- M. Provide pedestrian detours as necessary in areas adjacent to new construction following demolition of existing surface. The CONTRACTOR shall provide smooth, graded pathways, free of mud, muck and other materials that will be objectionable to people in street shoes. The pathways shall be a minimum of 36-inches wide, and shall be clearly marked with staking, warning ribbons, or other methods to guide pedestrians through the construction areas and to their residence walkways, if applicable.
- U. The CONTRACTOR shall coordinate with First Student, Inc. and Glacier Valley Elementary School as necessary to ensure safe, uninterrupted access for school buses and students when school is in session.

**SECTION 01550 – SITE ACCESS AND STORAGE, PART 1 – GENERAL, Article 1.3, MAINTENANCE OF TRAFFIC, *paragraph S, add the following:***

- 5. Contractor's active work zone shall be limited to 250 feet only. Work zones shall be returned to a safe and passable condition for vehicles and pedestrians at the end of each work shift.
- 6. Street closures shall be limited to the Contractor's work shift only. No street closures shall be permitted overnight. If the section has only one access, the closure to vehicular traffic shall be limited to five (5) minutes for each occurrence.

**SECTION 01570 – EROSION AND SEDIMENT CONTROL, PART 1 – GENERAL, Article 1.1, THE REQUIREMENT, *add following paragraph:***

- D. The area of disturbance for this project is more than 1 acre.

**SECTION 01700 – PROJECT CLOSE-OUT, PART 1 – GENERAL, Article 1.3, FINAL SUBMITTALS, Paragraph A. *Delete* items 6, 7 and 8 and *replace with the following sub-paragraph:***

- 6. Compliance Certificate and release, signed by the CONTRACTOR, shall be submitted to the Engineering Contract Administrator.

**SECTION 01700 – PROJECT CLOSE-OUT, PART 1 – GENERAL, Article 1.3, FINAL SUBMITTALS, *Add the following paragraph:***

- C. Before final payment, the CONTRACTOR shall provide the OWNER with clearance from the Alaska Department of Labor and Workforce Development for the CONTRACTOR and all Subcontractors that have worked on the Project. This clearance shall indicate that all Employment Security Taxes have been paid. A sample form for this propose is at the end of Section 00800 – supplementary General Conditions.

**SPECIAL PROVISIONS**

**SECTION 01700 – PROJECT CLOSE-OUT, PART 1 – GENERAL, *Replace the* COMPLIANCE CERTIFICATE AND RELEASE FORM *with the following form:***

**SPECIAL PROVISIONS**

**COMPLIANCE CERTIFICATE AND RELEASE FORM**

**PROJECT: Tongass Boulevard Reconstruction, Phase 1**  
**CONTRACT NO: BE21-150**

The **CONTRACTOR** must complete and submit this form to the Contract Administrator with respect to the entire contract and submit completed Subcontractor Compliance forms for each Subcontractor used on the Contract and listed on the Subcontractor report.

Completed forms shall be submitted upon completion of the Project. All requirements and submittals must be met before final payment will be made to the **CONTRACTOR**.

*I certify that the following and any referenced attachments are true:*

- All **WORK** has been performed, materials supplied, and requirements met in accordance with the applicable Drawings, Specifications, and Contract Documents.
- All payments to Subcontractors and Suppliers have been made in accordance with Alaska Statute 36.90.210. If not, please provide written explanation, for each case, why and the specific mutual payment agreement reached with the Supplier or Subcontractor.
- **CHECK ONE:**
  - All Suppliers and Subcontractors have been paid in full with no claims for labor, materials or other services outstanding.
  - The following Suppliers and Subcontractors are due final payment which will be made upon the release of the final payment by the CBJ. List the Suppliers and Subcontractors and the amount they are due below (attach separate sheet if necessary):

	Supplier or Subcontractor	Amount Owed
1.		\$
2.		\$
3.		\$
4.		\$
5.		\$
6.		\$
7.		\$

**SPECIAL PROVISIONS**

- All employees have been paid not less than the current prevailing wage rates set by the State of Alaska (or U.S. Department of Labor, as applicable).
- All equal employment opportunity, certified payroll and other reports have been filed in accordance with the prime contract.
- The attached list of Subcontractors is complete (required from CONTRACTOR). The City Engineer was advised and approved of all Subcontractors before WORK was performed and has approved any substitutions of Subcontractors.
- All DBE firms listed as a precondition of the prime contract award must have performed a commercially useful function in order for the WORK to count to a DBE goal. All DBE firms performed the WORK stated and have received at least the amount claimed for credit in the Contract Documents.
- All DBE Subcontractors must attach a signed statement of the payment amount received, the nature of WORK performed, whether any balance is outstanding, and indicate that no rebates are involved.
- If the amount paid is less than the amount originally claimed for DBE credit, the CONTRACTOR has attached approval from the City Engineer for underutilization.

*I understand it is unlawful to misrepresent information in order to receive a payment which would otherwise be withheld if these conditions were not met. I am an authorized agent of this firm and sign this freely and voluntarily. The foregoing statements are true and apply to the following project contractor.*

\_\_\_\_\_ Capacity: CONTRACTOR  
Firm Name

\_\_\_\_\_  
Signed Printed Name and Title Date

Return completed form to: Engineering Contracts Division, City and Borough of Juneau, 155 South Seward Street, Juneau, AK 99801 or by email to: [contracts@juneau.org](mailto:contracts@juneau.org)

Call (907) 586-0873 if we can be of further assistance or if you have any questions.

**SPECIAL PROVISIONS**

**SUBCONTRACTOR COMPLIANCE CERTIFICATE AND RELEASE FORM**

**PROJECT: Tongass Boulevard Reconstruction, Phase 1**  
**CONTRACT NO: BE21-150**

Each **SUBCONTRACTOR** must complete and submit this form to the Contract Administrator, through the General Contractor, with respect to the entire contract.

Completed forms shall be submitted upon completion of the Project. All requirements and submittals must be met before final payment will be made to the **CONTRACTOR**.

*I certify that the following and any referenced attachments are true:*

- All **WORK** has been performed, materials supplied, and requirements met in accordance with the applicable Drawings, Specifications, and Contract Documents.
  
- \_\_\_\_\_ (name of firm) has been paid by the Contractor in accordance with Alaska Statute 36.90.210. (If not, please provide written explanation on an attached sheet, for each case. Provide specific details why payment was not made and the specific mutual payment agreement reached with the Contractor if it is still unresolved.)
  
- **CHECK ONE:**
  - I / WE have been paid in full by the Contractor, with no claims for labor, materials or other services outstanding.
  
  - I / WE are due the following amount from the Contractor which is included in the Contractors Request for Final Payment. WE are due a total of \$ \_\_\_\_\_ for the following individual items that have yet to be paid (attach separate sheet if necessary).

	Outstanding Payment Item	Outstanding Amount Owed
1.		\$
2.		\$
3.		\$
4.		\$
5.		\$
6.		\$
7.		\$



**SPECIAL PROVISIONS**

- All employees have been paid not less than the current prevailing wage rates set by the State of Alaska (or U.S. Department of Labor, as applicable).
- All equal employment opportunity, certified payroll and other reports have been filed in accordance with the prime contract.

*I understand it is unlawful to misrepresent information in order to receive a payment which would otherwise be withheld if these conditions were not met. I am an authorized agent of this firm and sign this freely and voluntarily. The foregoing statements are true and apply to the following project contractor.*

\_\_\_\_\_ Capacity: SUBCONTRACTOR  
Firm Name

\_\_\_\_\_ Printed Name and Title  
Sign \_\_\_\_\_ Date

Prime Contractor shall return completed form to: Engineering Contracts Division, City and Borough of Juneau, 155 South Seward Street, Juneau, AK 99801, or email: greg.smith@juneau.org

Call (907) 586-0873 if we can be of further assistance or if you have any questions.

**END OF SECTION**

## SPECIAL PROVISIONS

**SECTION 02202 – EXCAVATION AND EMBANKMENT, PART 2 – PRODUCTS, *add the following Article:***

**2.9 USABLE MATERIAL FROM EXCAVATION**

- A. Usable material from excavation shall meet the requirements for Embankment.

**SECTION 02202 – EXCAVATION AND EMBANKMENT, PART 3 – EXECUTION, Article 3.7, 2-INCH MINUS SHOT ROCK w/BASE COURSE, *add the following paragraph:***

- B. If base course, Grading D-1 is used as a leveling course for the curb and gutter, all of this base course material shall be removed from the 2-inch minus shot rock to the front face of the concrete gutter, and the additional 2-inch minus shot rock required to bring the street area to its required full depth be placed, graded and compacted prior to placing the top layer of base course, Grading D-1.

**SECTION 02203 – TRENCHING, PART 2 - MATERIALS, Article 2.2 BEDDING, *replace paragraph A with the following:***

- A. Pea gravel, or similar open graded product, shall not be used for bedding. Class A bedding material shall be used for all water and sanitary sewer pipes installed on this project. Class B bedding material shall be used for all storm drain pipes installed on this project.

**SECTION 02204 – BASE COURSE, PART 2 - PRODUCTS, Article 2.1 MATERIAL, *add the following paragraph:***

- E. Base course for this Project shall have a maximum Nordic Abrasion Value of 18, as determined by ATM 312, and shall meet the gradation requirements for grading D-1.

**SECTION 02204 – BASE COURSE, PART 3 – EXECUTION Article 3.1, GENERAL, *replace Paragraph I with the following:***

- I. The surface of the base course, when using a taut string line or straight edge of adequate length, spanning between two known grade control points (blue top hubs, lip of gutter, edge existing asphalt etc.) shall not show any deviation in excess of 3/8 inch. This shall be checked perpendicular and longitudinally to the grade control points and be documented by the INSPECTOR. The finish surface shall not vary more than 1/2 inch from established grade. Additionally, the algebraic average of all deviations from established grade of the finish base course surface elevations taken at 50-foot intervals shall be less than 0.02 foot.

**SECTION 02401 – SANITARY SEWER PIPE, PART 3 - EXECUTION, Article 3.1, CONSTRUCTION, *replace paragraph O with the following:***

- O. Locate Sanitary Sewer Services shall require that the CONTRACTOR verify the location and depth of each sewer service pipe along the proposed storm drain mainline alignment. These verifications will require that the sewer service pipe be excavated at the storm drain pipe crossings so a visual check can be made that no damage occurs during trenching and backfilling operations.
  - 1. The CONTRACTOR shall notify the ENGINEER when each crossing will occur with enough time for the ENGINEER to be present during the excavation operations.

## SPECIAL PROVISIONS

2. The CONTRACTOR shall take all measurements necessary to ensure no damage occurs to the sewer services or the main line piping during its operations. The CONTRACTOR shall spray paint the sewer service alignment prior to proof rolling the subgrade.
3. All sewer service piping damaged as a result of the CONTRACTOR's operations shall be repaired at the CONTRACTOR's expense.
4. Some sewer services may be found to be at, or close to the roadway and sidewalk subcut levels. The CONTRACTOR shall take all measures necessary to ensure no damage occurs to the sewer services or the main line piping during its operations.

**SECTION 02402 – SANITARY SEWER MANHOLES AND CLEANOUTS, PART 3 - EXECUTION,** Article 3.1, CONSTRUCTION, Paragraph M, *delete sub-paragraph 4 and replace with the following:*

4. Rubber grade ring adjustment risers shall be bonded to adjacent surfaces by laying at least 3 beads, a minimum of 5/16" thick of Liquid Nails –Polyurethane Construction Adhesive on each side of the rubber risers or the top surface of the concrete course. Two of the adhesive beads shall be within 1" of the edges of the rubber grade ring adjustment riser, the third shall be equidistant between the two outer beads. The beads shall be continuous around the rubber grade ring adjustment riser.

**SECTION 02402 – SANITARY SEWER MANHOLES AND CLEANOUTS, PART 3 - EXECUTION,** Article 3.1, CONSTRUCTION, *add the following paragraph:*

- P. The CONTRACTOR shall repair all imperfections and leaks disclosed by either visual inspection or testing. The method of repair shall be subject to the ENGINEER's approval.

**SECTION 02501 – STORM SEWER PIPE, PART 2 – PRODUCTS,** Article 2.6, CORRUGATED POLYETHYLENE PIPE, *delete paragraphs B and C and replace with the following:*

- B. Pipe shall be joined with "ADS, Inc. N-12" (bell-and-spigot) water-tight (WTIB), or approved equal, meeting the requirements of AASHTO M252 or AASHTO M 294 or ASTM F2306. The pipe joining system shall be water-tight integral bell & gasketed spigot meeting the requirements of ASTM D3212 or equivalent standard.
- C. The bell-and-spigot joint shall be water-tight and incorporate a gasket meeting the requirements of ASTM F477 or equivalent standard. Gaskets shall be installed in the bell, or on the pipe, by the pipe manufacturer and covered with a removable wrap to ensure the gasket is free from debris at the time of installation. A joint lubricant shall be used on the gasket and bell during assembly.

**SECTION 02501 – STORM SEWER PIPE, PART 2 – PRODUCTS,** *add the following Article:*

### 2.10 6-INCH UNDERDRAIN

- A. Pipe shall be perforated, smooth interior pipe and shall meet the requirements of Article 2.6, Corrugated Polyethylene Pipe, of this Section.
- B. Drainage rock shall be 2-inch minus shot rock and shall meet the requirements of Section 02202 – Excavation and Embankment, Article 2.8, 2-Inch Minus Shot Rock.
- C. Filter cloth shall be Type A and shall meet the requirements of Section 02714 – Filter Cloth.

## SPECIAL PROVISIONS

- D. Cleanouts shall be PVC with cast iron frame and lids.

**SECTION 02502 – STORM SEWER MANHOLES, INLETS AND CATCH BASINS, PART 3 - EXECUTION, Article 3.1, CONSTRUCTION, *delete paragraph P and replace with the following:***

- P. All storm drain manholes and storm drain catch basin structures shall be constructed on a pad of 2” minus shot rock a minimum 24-inches thick to provide a stable base pad.

**SECTION 02601 – WATER PIPE, PART 2 – PRODUCTS, Article 2.3, FITTINGS, *delete* paragraph J and *replace* with the following:**

- J. Electrofusion couplers are discouraged and may only be allowed with prior, written approval of the ENGINEER. Not having a fusion machine capable of being placed in the excavation to accomplish butt fusion is not an acceptable reason for use of an electrofusion coupler.

**SECTION 02601 – WATER PIPE, PART 2 – PRODUCTS, Article 2.9, TEMPORARY WATER SYSTEM, *add* the following paragraphs:**

- B. No WORK shall begin with the installation of a temporary water system until all affected residents have been notified a minimum of 24 hours in advance. At least one member of each household shall have the installation method explained to them, with an estimate of the duration of the use of the temporary water system.
- C. The existing Tongass Boulevard water main is the primary fill line for the East Valley reservoir located at the end of Dudley Street. Maximum allowable shutdown time for this line is 8 hours. Shutdown times may be reduced or not allowed at a specific time because of weather or other factors. Weather or other factors may require that the water main shutdown occur at night. Water flow capacity shall be maintained if the Contractor plans to install a temporary bypass line. All temporary water system plans, and interruptions shall be reviewed and approved by the CBJ Water Utility Department prior to implementation. The Contractor shall demonstrate that adequate labor-force and all parts and tools will be provided to complete the work within the approved shutdown time.

**SECTION 02601 – WATER PIPE, PART 3 – EXECUTION, Article 3.5, HYDROSTATIC TESTING, *add* the following paragraphs:**

- K. At no time shall the CONTRACTOR pressure test against existing valves, plugs, caps, fire hydrants or curb stops. At no time shall the CONTRACTOR use disinfection water or untreated water to pressure test against any valve or curb stop that is connected to a public water system.
- L. Pressure testing shall be completed for the entire length of new water pipe and services to the limits where new water pipes and services connect to existing water pipes and services, including pressure testing to the limits of connection to existing fire hydrant legs. The CONTRACTOR is responsible for providing all temporary or permanent joint restraints, thrust blocks, fittings, caps, plugs, curb stops and valves necessary for completion of pressure testing activities in accordance with SECTION 02601 and to the satisfaction of the ENGINEER.

## SPECIAL PROVISIONS

**SECTION 02601 – WATER PIPE, PART 3 – EXECUTION, Article 3.8, CONNECTIONS TO EXISTING PIPES, *add* the following paragraph:**

All flushing, pressure testing, and disinfection of new water pipes shall be completed in accordance with SECTION 02601 and accepted by the ENGINEER prior to making final or permanent connections to existing water pipes and services. At no time during flushing, pressure testing, or disinfection activities shall there be a temporary or permanent cross-connection between new water pipe and existing water pipe or services, unless otherwise approved by the ENGINEER or a backflow prevention assembly meeting ANSI/AWWA Standards C510-97 or C511-97 is used to ensure no backflow into the existing and unprotected public water system occurs.

**SECTION 02605 – WATER SERVICES, PART 3 – EXECUTION, Article 3.1, CONSTRUCTION, *add* the following paragraph:**

- I. The location of the existing water services lines shown on the drawings are based off limited as-built information, field locates and resident comments and are not considered reliable indications of actual locations. The CONTRACTOR is responsible for all work required to field locate the existing service lines to verify their location. These services may not run in a straight line to the water main as shown. The CONTRACTOR shall verify the connection location, material, size, and depth of each water service pipe.

**SECTION 02702 – CONSTRUCTION SURVEYING, PART 3 – EXECUTION, Article 3.1, CONSTRUCTION, *add* the following paragraphs:**

- M. A closed level loop is required through Temporary Bench Marks (TBMs) listed in the Drawings. No side shots will be permitted. A copy of the surveyor's notes shall be provided to the ENGINEER. No payment will be made for Pay Item No. 2702.1 until the ENGINEER has received a copy of these surveyor's notes.
- N. Global Position System (GPS) survey methods shall not be used for grading control unless approved in writing by the ENGINEER.

**SECTION 02709 – TOPSOIL, PART 2 – PRODUCTS, Article 2.1, MATERIALS, *revise* the first sentence of paragraph C to read:**

- C. Topsoil shall contain not less than 8% or more than 20% organic matter by weight, as determined by loss-on-ignition of oven-dried samples in accordance with ASTM T-6.

**SECTION 02709 – TOPSOIL, PART 3 – EXECUTION, Article 3.1, CONSTRUCTION, *revise* paragraph A to read:**

- A. All areas beyond the roadway shoulder, sidewalk, and driveway edges that require regrading or are otherwise disturbed during construction, shall be graded to a neat, uniform, well-drained grade lines and appearance, as determined by the ENGINEER. These areas shall be hydroseeded, unless otherwise shown on the Drawings, or directed by the ENGINEER.

**SECTION 02709 – TOPSOIL, PART 3 – EXECUTION, Article 3.1, CONSTRUCTION, *add* the following:**

- F. No topsoil shall be placed on the graded slope areas unless these areas can be finish graded and seeded within 30 days of the date originally placed. Topsoil shall be consolidated/rolled

## **SPECIAL PROVISIONS**

by a water filled lawn roller or other ENGINEER approved method prior to application of seed. Topsoil placed, but not finish graded or seeded within 30 days, will be deducted from payment until the topsoil has been scarified, graded and supplemented with additional topsoil as required to provide a smooth, well graded and scarified surface suitable for seeding, as determined by the ENGINEER. All additional topsoil required after 30 days of the original placement will not be measured for payment but will be considered incidental to other WORK.

**SECTION 02716 – REMOVE AND DISPOSE OF CULVERT PIPE**, *delete in its entirety and replace with the following Section:*

### **SECTION 02716 – STORM AND SANITARY SEWER PIPE REMOVAL AND WATER PIPE SLURRY**

#### **PART 1 - GENERAL**

##### 1.1 DESCRIPTION

- A. The WORK under this Section includes providing all labor, tools and equipment necessary for removal and disposal of existing storm drainage pipe, sanitary sewer pipe, and the existing water system or filling the existing water pipes with cement slurry within the project limits designated for removal.

#### **PART 2 – PRODUCTS**

##### 2.1 MATERIALS

- A. Cement slurry used to fill conveyance structures prior to abandonment shall consist of a flowable mixture of cement, water, sand, and additives that, when cured for three (3) days, will have a minimum compressive strength of 150 pounds per square inch (psi). A cement slurry design shall be submitted by the CONTRACTOR for approval by the ENGINEER prior to use.

#### **PART 3 – EXECUTION**

##### 3.1 GENERAL

- A. All storm drainage pipe, 4-inches or larger, shown on the Drawings for removal shall be removed and backfilled with suitable material to match the adjacent ground surface. Usable material from excavation shall be used as backfill. Disposal of the pipe shall be in accordance with these Specifications.
- B. Existing water main pipe, services, water valves, valve boxes, fittings, thrust blocks, and other water system components shall be removed in their entirety and disposed of in accordance with the Contract Documents, as shown on the Drawings and as directed by the ENGINEER.
- C. All materials removed during performance of the WORK described herein shall become the property and responsibility of the CONTRACTOR.

## SPECIAL PROVISIONS

- D. Voids shall be backfilled with suitable material to match the adjacent ground surface or bottom of subcut, and placement of material used for backfill shall not exceed 2-foot lifts. Usable material from excavation may be used as backfill as approved by the ENGINEER, and all backfill placed shall be compacted to the satisfaction of the ENGINEER.
- E. Where shown on the Drawings, existing water pipes shall be abandoned in place by filling with Cement Slurry to a minimum of eighty percent (80%) capacity of the calculated volume based on the length and inside diameter of the conveyance structure being abandoned. If necessary, all pumps, vent tubes, and WORK to open or remove additional sections of the existing conveyance structure for meeting the minimum volume filled requirement shall be the responsibility of the CONTRACTOR.

### END OF SECTION

**SECTION 02718 – SIGN ASSEMBLY, PART 3 – EXECUTION, Article 3.1, GENERAL, *add the following:***

- H. Sign assemblies shall be installed as detailed in the Sign Assembly Table on the Drawings.

*Add the following Section:*

## SECTION 02722 – ELECTRICAL UTILITIES

### PART 1 - GENERAL

#### 1.1 DESCRIPTION

- A. The WORK under this Section includes subcontracting or otherwise arranging with AEL&P, ACS or GCI for any work with the power, telephone and television services, respectively, for the WORK shown on the Drawings or described in this Section. This includes relocation of existing conductors of the respective utility companies.

### PART 2 – PRODUCTS

#### 2.1 MATERIALS

- A. Materials shall be as specified by the owner of the private utility service company.
- B. Materials shall conform to the requirements of the National Electrical Code.

### PART 3 – EXECUTION

#### 3.1 CONSTRUCTION

- A. Construction shall be in accordance with the agreement arranged by the CONTRACTOR with the owner of the utility service being relocated, except that the Drawings and Specifications shall take precedence in the event of a conflict.
- B. All WORK with the electrical utilities shall conform to the requirements and standards established by the private utility companies and shall meet all applicable codes and regulations.

## **SPECIAL PROVISIONS**

- C. The WORK under this Section does not include excavating, backfilling, or any other work under, around, or along electrical utilities that are not in direct conflict with other WORK.

### **3.2 ELECTRICAL CONDUCTOR RELOCATIONS**

- A. The WORK under this Item include only those electrical conduit or conductor relocations required due to a direct conflict with new piping or structures, and that are 3-inches or less in diameter.

### **3.3 SHORING AND SUPPORTING UTILITY PEDESTAL**

- A. The WORK under this Item include only those power, telephone, or cable TV pedestals in direct conflict with new piping, roadway improvements or structures or as shown on the Drawings. The WORK shall include all conduit, conductor, wire, splices and pedestals to satisfactorily shore and support the existing pedestal as shown on the Drawings or as directed by the ENGINEER to allow the underground utility installation work to be installed.

## **END OF SECTION**

*Add the following Section:*

## **SECTION 02723 – REMOVE AND RELOCATE LANDSCAPING**

### **PART 1 – GENERAL**

#### **1.1 DESCRIPTION**

- A. The WORK under this Section includes providing all labor, materials, tools and equipment necessary for removing existing landscaping items and relocating onto private property those landscaping items that conflict with the proposed construction improvements that have not been relocated by the owner of such landscaping, as directed by the ENGINEER. The WORK also includes removing and resetting landscape boulders in front of Glacier Valley Elementary as necessary for construction of new work.
- B. The existing landscaping improvements within the Project limits include, but are not limited to, the following: landscaping trees, landscaping shrubs, flowers, wood planter boxes, timber landscaping borders and rock walls/gardens.

### **PART 2 - PRODUCTS**

#### **2.1 MATERIALS**

- A. Materials shall be existing landscaping features and improvements left within the construction limits.

### **PART 3 - EXECUTION**

#### **3.1 GENERAL**



**SPECIAL PROVISIONS**

- A. The CONTRACTOR shall notify each property owner whose plantings, or other landscape items are to be disturbed, a minimum of seven (7) days in advance of disturbing these plantings, or other landscape items. This includes all items fronting on the property from the edge of the paved street towards the residence that conflict with construction.
- B. If the property owner requests to have the plantings or other landscaping items disposed of, the CONTRACTOR shall remove and dispose of these items at no additional cost to the OWNER.
- C. If the property owner requests to remove and set aside the plantings, or other landscaping items themselves, the CONTRACTOR shall provide a minimum of seven (7) days to the property owner for this WORK.

**END OF SECTION**

**SECTION 02801 – ASPHALT CONCRETE PAVEMENT, PART 1 – GENERAL, Article 1.1, DESCRIPTION, *revise paragraph B as follows and add paragraph C:***

- B. Roadway asphalt concrete mix for this Project shall be Type II-A, Class B. See Table 02801-1 and Table 02801-2.
- C. Asphalt concrete mix for sidewalks, driveways and hydrant pads may be either Type III, Class B, or Type II-A, Class B. See Table 02801-1 and Table 02801-2.

**SECTION 02801 – ASPHALT CONCRETE PAVEMENT, PART 1 – GENERAL, Article 1.1, DESCRIPTION, Table 02801-1 ASPHALTIC CONCRETE MIX REQUIREMENTS *revise the table as follows:***

<u>DESIGN PARAMETERS</u>	<u>CLASS A</u>	<u>CLASS B</u>
Voids in total mix, percent	2.5 – 4.0	2.5 – 4.0%
Percent oil content	5.8 – 6.8	5.8 – 6.8%

**SECTION 02801 – ASPHALT CONCRETE PAVEMENT, PART 2 - PRODUCTS, Article 2.1, COMPOSITION OF ASPHALT CONCRETE MIXTURES – JOB MIX DESIGN, Paragraph C: *delete subparagraph 6 and replace with the following:***

- 6. The mix design shall be 50 blow Marshall Method.

**SECTION 02801 – ASPHALT CONCRETE PAVEMENT, PART 2 - PRODUCTS, Article 2.3, ASPHALT MATERIALS, *delete paragraph B and replace with the following:***

- B. ASPHALT CEMENT
  - 1. Asphalt cement shall be designated PG 58-28 PLUS.

**SECTION 02801 – ASPHALT CONCRETE PAVEMENT, PART 2 - PRODUCTS, *add the following Article:***

**2.6 RECLAIMED ASPHALT PAVEMENT**

## SPECIAL PROVISIONS

- A. Reclaimed Asphalt Pavement (RAP) may be used in the asphalt mix up to 20% of the total mix.
- B. RAP will be available at no cost from the CBJ Lemon Creek Stockpile. The contractor will notify Michael Eich, CBJ Pits and Quarries Manager, 586-0874, of quantity needed, to coordinate access and for Lemon Creek Gravel Pit permit compliance requirements, prior to taking any RAP. The Contractor shall weigh each load at the CBJ scales and record on a CBJ scale ticket. The CBJ makes no guarantees of the quantity or quality of the RAP.
- C. The Contractor shall provide a mix design showing the inclusion of the specified percentage of RAP according to the mix design requirements in this section.
- D. Use of RAP in the Contractor's asphalt mix does not nullify any of the other specification requirements or associated asphalt quality deductions.

**SECTION 02801 – ASPHALT CONCRETE PAVEMENT, PART 3 - EXECUTION, Article 3.2, EQUIPMENT, Paragraph C, *delete item 2 and replace with the following:***

- 2. Each truck shall have a watertight canvas cover of such size as to extend at least one foot over the sides and end of the truck bed and be adequately secured to protect the asphalt concrete mixture. The use of canvas covers will be required at all times.
- 3. The Contractor shall make the trucks to be used for hauling the asphalt concrete mixture available for inspection by the Engineer prior to paving day and shall be identified in the Paving Plan. Trucks that do not meet the requirements of this section may be rejected by the Engineer and not allowed on the project unless the deficiencies are remedied and approved by the Engineer in advance of hauling asphalt. Use of trucks not approved for delivery by the Engineer may result in the rejection of the asphalt concrete mixture within the unapproved truck.

**SECTION 02801 – ASPHALT CONCRETE PAVEMENT, PART 3 - EXECUTION, Article 3.2, EQUIPMENT, *add the following paragraph:***

- E. Heavy, full size, self-propelled laydown units that will place concentrated loading on curb and gutter sufficient to cause breakage, or other damage to the concrete, will not be permitted.

**SECTION 02801 – ASPHALT CONCRETE PAVEMENT, PART 3 - EXECUTION, Article 3.8, SPREADING AND PLACING, *delete paragraph H and replace with the following:***

- H. Manhole frame and covers and water valve boxes shall be set to final grade in accordance to CBJ Standard 205 – MANHOLE HEIGHTS and 407 – MAINLINE VALVE, prior to paving operations. If the cover lugs or frame, whichever is higher, does not meet the required depression range following the finish paving operations, the CONTRACTOR shall construct a transition slab with asphalt pavement overlay, per CBJ Standard 126 – CONCRETE COLLAR, at no additional cost to the OWNER.

**SECTION 02801 – ASPHALT CONCRETE PAVEMENT, PART 3 - EXECUTION, Article 3.8, SPREADING AND PLACING, *add the following paragraph:***

## SPECIAL PROVISIONS

- K. The Contractor shall hold a pre-paving conference on site with the Engineer to review and verify the accuracy of the Paving Plan prior to paving day. The paving foreman shall be present to explain each of the operational details included in the paving plan.

**SECTION 02801 – ASPHALT CONCRETE PAVEMENT, PART 3 - EXECUTION, Article 3.10, JOINTS, *replace paragraph C with the following:***

- C. Improperly formed asphalt joints resulting in surface irregularities or rock segregation shall be removed, full road width, replaced with new material, and thoroughly compacted. The edge of pavement along the centerline joint shall not be allowed to drop below 200 degrees Fahrenheit prior to the asphalt mix from the adjacent lane being placed against this edge.

**SECTION 02801 – ASPHALT CONCRETE PAVEMENT, PART 3 – EXECUTION, Article 3.10, JOINTS, *add* the following paragraph:**

- J. All joints with existing asphalt pavement shall be resealed with asphalt cement after the new pavement has cooled to ambient temperature. All joints with concrete gutters found to have a gap shall be blown out using a weed burner torch, filled with asphalt cement, and covered with a layer of dry sand. Excess sand shall be removed, and asphalt cement placed on the concrete gutter more than one-inch from the edge of gutter shall be removed using solvent or other approved methods.

**SECTION 02801 – ASPHALT CONCRETE PAVEMENT, PART 3 - EXECUTION, Article 3.13, Acceptance Sampling and Testing, *add the following paragraph:***

- K. For each lot of asphalt pavement produced, at least two (2) samples shall be taken by the CONTRACTOR for purposes of acceptance testing by the OWNER. The CONTRACTOR shall split the sample with the OWNER to retain a portion for their use. The sample shall be taken according to proper sampling methods, from the asphalt pavement on the grade.

The deduction amounts will be determined from the OWNER's acceptance testing results. The values will be calculated by averaging the amount of the absolute value of the two tests outside the job mix design tolerance (the difference between the actual test result and the job mix design tolerance range). A test value within the job mix design tolerance will be considered a zero (0) value for averaging the two values. Deduction from the asphalt pavement pay item shall be made at the following amounts:

1. #200 Sieve: the greater of either 1.0% the contract price for asphalt pavement placed within the sampled lot or \$500 per each 0.1% outside the job mix design tolerance, not exceeding 6% maximum, of the percent passing the #200 sieve. The allowable tolerance for this Contract shall be  $\pm 1.0\%$  of the target mix design value and shall not exceed the content limits specified in this Contract. If values fall outside of the allowable tolerance, deductions shall be calculated from the mix design target value.
2. Asphalt Content: the greater of either 1.0% of the contract price for asphalt pavement placed within the sampled lot or \$500 per each 0.1% outside the allowable job mix design asphalt content tolerance. The allowable asphalt content tolerance for this Contract shall be  $\pm 0.4\%$  of the target job mix design value and not to fall below a value of 5.6%. If values fall outside of the allowable tolerance, deductions shall be calculated from the mix design target value.

## SPECIAL PROVISIONS

The pay deductions for exceeding the job mix design tolerances does not constitute acceptance of a mix that does not meet the specifications. Further acceptance testing will be performed to determine if the asphalt pavement specifications have been met. No payment for asphalt pavement will be made for asphalt pavement exceeding job mix design tolerances, or not meeting asphalt pavement specifications, until additional testing determines whether the asphalt pavement meets all other specifications.

For the purposes of this Contract, one lot of asphalt pavement is defined as 500 tons, or a single day's asphalt pavement production of at least 100 tons.

### SECTION 03302 – CONCRETE STRUCTURES, PART 3 – EXECUTION, *add the following Articles:*

#### 3.4 CONCRETE HEADWALLS WITH HINGED TRASH RACK

- A. Concrete Headwalls shall conform to CBJ Standard Detail 104A, with adjustments to match the site conditions and grades, as approved by the ENGINEER. No concrete shall be placed in the forms until the formwork has been approved by the ENGINEER.

#### 3.5 CONCRETE AREA DRAINS

- A. The Concrete Area Drains shall conform to CBJ Standard Detail 310 – Area Drain Detail. The CONTRACTOR shall set the form boxes loosely in place, and then request the ENGINEER to work with the CONTRACTOR to establish the final positioning of the forms and the finish grade lines within the forms prior to placing concrete.

### SECTION 03303 – SIDEWALK, CURB AND GUTTER, PART 2 – PRODUCTS, Article 2.1, MATERIALS, *revise paragraph B to read:*

- B. Synthetic fibers shall be used for reinforcement with curb & gutter. Reinforcing steel or wire mesh shall not be used unless approved by the ENGINEER. Curb & gutter shall utilize a fibrillated product, 300 mm in length, such as Fibermesh 300, or approved equal. Application rate shall be at least 1.5 pounds per cubic yard of concrete. Fibermesh shall be as manufactured by “SI Concrete Systems” or approved equal.

### SECTION 03303 – SIDEWALK, CURB AND GUTTER, PART 2 – PRODUCTS, Article 2.1, MATERIALS, *add the following paragraph:*

- C. Detectable tiles shall be cast iron detectable warning plates with truncated dome pattern, a slip resistant surface, and with handle or flange on bottom or approved equal. Detectable warning plates shall be coated with yellow polymer-soaked finish and manufactured according to the 2006 U.S. DOT ADA Standards for Transportation Facilities.

### SECTION 03303 – SIDEWALK, CURB AND GUTTER, PART 3 – EXECUTION, Article 3.1, METHODS OF CONSTRUCTION, *add the following paragraphs:*

- K. All forms for segments between PC's and PT's with a radius of less than 100' shall be arced to match required curvature. No straight forms will be permitted for use within the curved segments with a radius of less than 100'. Straight forms used for any arced segment with a radius greater than 100' shall not exceed 10' in length.

## SPECIAL PROVISIONS

- L. The CONTRACTOR shall protect all newly placed concrete from damage of any kind to prevent disfigurement during the curing period. Damaged concrete shall be repaired or replaced to the ENGINEER's satisfaction at no additional cost to the OWNER.

### END OF SECTION

*Add the following Section:*

## SECTION 260000 – GENERAL ELECTRICAL REQUIREMENTS

### PART 1 – GENERAL

#### 1.1 RELATED REQUIREMENTS

- A. Drawings and general provisions of the Contract, including General and Supplementary Conditions and Division 1 Specifications Sections, apply to this Section.
- B. This section applies to all sections of Division 26 “Electrical”, unless specified otherwise.
- C. The Civil Drawings shall be examined for coordination and familiarity of work with other Contractors. Any duplication or omission of provisions in this project shall be brought to the attention of the Owner prior to Bidding.

#### 1.2 DESCRIPTION

- A. The General Conditions and Supplementary General Conditions are part of this Division and are to be considered a part of this Contract.
- B. Where items of the General Conditions and Supplementary General Conditions are repeated in other Sections of the Specifications, it is merely intended to qualify or to call particular attention to them. It is not intended that any other parts of the General Conditions and Supplementary General Conditions shall be assumed to be omitted if not repeated therein. This Section applies equally and specifically to all Contractors supplying labor and/or equipment and/or materials as required under each Section of this Division. Where conflicts exist between the drawings and the specifications or between this section of the specifications and other sections, the more stringent or higher cost option shall apply.
- C. It is the intent of this Section of the Specifications to establish a standard of quality and performance characteristics for basic materials and installation methods used in building electrical systems.

#### 1.3 INTENT

- A. This Contract is for all labor, materials and equipment required for installation. The system shall be complete and finished in all respects, tested and ready for operation. Work shall include calibration of equipment with factory settings. All materials, equipment and apparatus shall be new and of high quality.
- B. Any apparatus, appliance, material or Work not shown on the Drawings but mentioned in the specification, or vice versa, or any incidental accessories necessary to make the Work complete

## SPECIAL PROVISIONS

in all respects and ready for operation as determined by good trade practice even if not particularly specified, shall be furnished, delivered and installed under their respective Divisions without any additional expense to the Owner.

- C. Minor details not usually shown or specified but necessary for proper installation and operation shall be included in the Work as though they were hereinafter shown or specified.
- D. Work under each Section shall include giving written notice to the Owner of any materials or apparatus believed inadequate or unsuitable; in violation of laws, ordinances, rules or regulations of Authorities Having Jurisdiction; and any necessary items of Work omitted. In the absence of such written notice, it is mutually agreed that Work under each Section has included the cost of all required items for the accepted, satisfactory functioning of the entire system without extra compensation.
- E. Locations of all existing systems and equipment shown on the Drawings are based on the best available information. The Contractor shall verify all dimensions and locations of existing systems and equipment in the field and adjust as necessary.
- F. Wherever a particular piece of equipment, device or material is specifically indicated on the Drawings by model number, type, series or other means, that specification shall take precedence over equipment or materials specified herein.

### 1.4 DEFINITIONS

- A. “Subcontractor” means the subcontractor working under this Division. Other Contractors are specifically designated “Mechanical Contractor”, “General Contractor”, and so on. Take care to ascertain limits of responsibility for connecting equipment which requires connection by two or more trades.
- B. “Install” shall mean set in place complete with all mounting facilities and connections as necessary ready for normal use or service.
- C. “Furnish” or “supply” shall mean purchase, deliver to, and off-load at the job site, all ready to be installed including where appropriate all necessary interim storage and protection.
- D. “Provide” shall mean furnish (or supply) and install as necessary.
- E. “Finished” refers to all rooms and areas scheduled to be painted in Room Finish Schedule on the Drawings. All rooms and areas not covered in Room Finish Schedule, including areas above ceilings shall be considered not finished, unless otherwise noted.
- F. “Approved equal” means any product which in the opinion of the Engineer is equal in quality, arrangement, appearance, and performance to the product specified.
- G. “Wiring” shall mean cable assembly, raceway, conductors, fitting and any other necessary accessories to make a complete wiring system.
- H. “Product” shall mean any item of equipment, material, fixture, apparatus, appliance or accessory installed under this Division.

## SPECIAL PROVISIONS

- I. Substitutions: Requests for changes in products, materials, equipment, and methods of construction required by Contract Documents proposed by the Contractor after award of the Contract are considered requests for “substitutions.”
- J. Indicated: The term “indicated” refers to graphic representation, notes, or schedules on the Drawings, other paragraphs or schedules in the Specifications, and similar requirements in the Contract Documents. Where terms such as “shown,” “noted,” “scheduled,” and “specified,” are used, it is to help the reader locate the reference; no limitation on location is intended.
- K. Directed: Terms such as “directed,” “requested,” “authorized,” “selected,” “approved,” “required,” “and “permitted” mean “directed by the Engineer,” “requested by the Engineer,” and similar phrases.
- L. Approve: The term “approved,” where used in conjunction with the Engineer’s action on the Contractor’s submittals, applications, and requests, is limited to the Engineer’s duties and responsibilities as stated in General and Supplementary Conditions.
- M. Regulation: The term “Regulations” includes laws, ordinances, statutes, and lawful orders issued by authorities having jurisdiction, as well as rules, conventions, and agreements within the construction industry that control performance of the Work.
- N. Remove: The term “remove” means to disconnect from its present position, remove from the premises and to dispose of in a legal manner.
- O. Standard Product Warranties are preprinted written warranties published by individual manufacturers for particular products and are specifically endorsed by the manufacturer to the Owner.
- P. Special Warranties are written warranties required by or incorporated in the Contract Documents, either to extend time limits provided by standard warranties or to provide greater rights for the Owner.

### 1.5 DRAWINGS

- A. Drawings are diagrammatic and indicate the general arrangement of systems and Work included in the Contract. Consult the Civil Drawings for exact location of fixtures and equipment, where same are not definitely located, obtain this information from the Civil Engineer. Do not scale the Drawings.
- B. The Owner may, without extra charge, make reasonable modification in the layout as needed to prevent conflict with Work of other trades and/or for proper execution of the Work. A relocation of up to 10-feet would be considered reasonable.
- C. Where variances occur between the Drawings and the Specifications or within either of the Documents, the item or arrangement of better quality shall be included in the Contract price. The Owner and Engineer shall decide on the item and the manner in which the Work shall be installed.

## SPECIAL PROVISIONS

### 1.6 SURVEYS AND MEASUREMENTS

- A. Before submitting his Bid, the Contractor shall visit the site and become thoroughly familiar with all existing conditions under which his work will be installed. This Contract includes all necessary offsets, transitions and modifications required to install all new equipment. All new equipment and systems shall be fully operational under this Contract before the job is considered complete. The Contractor shall be held responsible for any assumptions he makes, and omissions or errors he makes as a result of his failure to become fully familiar with the existing conditions at the site and the Contract Documents.
- B. The Contractor shall base all measurements, both horizontal and vertical, from established bench marks. All Work shall agree with these established lines and levels. Verify all measurements at the site and check the correctness of same as related to the Work.
- C. Should the Contractor discover any discrepancies between actual measurements and those indicated which prevent following good practice or which interfere with the intent of the Drawings and Specifications, the Engineer will be notified and Work will not proceed until instructions from the Engineer are received.

### 1.7 CODES AND STANDARDS

- A. Reference Standard Compliance
  - 1. Where equipment or materials are specified to conform to industry and technical society reference standards of the organizations such as American National Standards Institute (ANSI), American Society for Testing and Materials (ASTM), National Electrical Manufacturers Association (NEMA), and Underwriters Laboratories Inc. (UL), submit proof of such compliance. The label or listing by the specified organization will be acceptable evidence of compliance.
  - 2. Independent Testing Organization Certificate: In lieu of the label or listing, indicated above, submit a certificate from an independent testing organization, competent to perform testing, and approved by the Engineer. The certificate shall state that the item has been tested in accordance with the specified organization's test methods and that the item complies with the specified organization's reference standard.
- B. The following Codes and Standards apply to all electrical work. Wherever Codes and/or Standards are mentioned in these Specification, the latest applicable edition or revision shall be followed:

The National Electrical Code with CBJ amendments.

- C. The following Standards shall be used where referenced by the following abbreviations:
  - ANSI American National Standards Institute
  - ASTM American Society of Testing and Materials
  - IEEE Institute of Electrical and Electronics Engineers
  - NEMA National Electrical Manufacturers Association
  - NSC National Safety Council
  - OSHA Occupational Safety and Health Administration
  - UL Underwriter's Laboratories



## SPECIAL PROVISIONS

- D. All materials furnished and all work installed shall comply with the requirements of the local utility company and of all Governmental departments having jurisdiction.
- E. The Contractor shall include in the work, without extra cost to the Owner, any labor, materials, services, apparatus, and Drawings in order to comply with all applicable laws, ordinances, rules and regulation, whether shown on Drawings and/or specified or not.

### 1.8 PERMITS AND FEES

- A. The Contractor shall give all necessary notices, obtain all permits; and pay all Government and State sales taxes and fees where applicable, and other costs, including utility connection or extensions in connection with the work, file all necessary Drawings, prepare all documents and obtain all necessary approvals of all Governmental and State departments having jurisdiction, obtain all required certificates of inspection for his work, and deliver a copy to the Owner and Engineer before request for acceptance and final payment for the work.

### 1.9 EQUIPMENT SUBSTITUTIONS

- A. In these Contract Documents, one or more makes of materials, apparatus or appliances may have been specified for use in this installation. These describe the basis of design and approved equivalents. This has been done for convenience in fixing the standard of workmanship, finish and design required for the installation without consideration of any or all associated costs. The Contractor acknowledges that not all requirements are shown for either alternate acceptable manufacturers listed or those alternates requiring a request for substitution and it is their responsibility to coordinate all requirements necessary to accommodate any change from the basis of design listed or scheduled. The Contractor is required to submit any and all costs (including costs associated or required by all trades) along with performance differences as part of their request for substitution. The details of workmanship finish and design, and the guaranteed performance of any material, apparatus or appliance which the Contractor desires to deviate for those mentioned herein shall also conform to these standards.
- B. Where no specific make of material, apparatus or appliance is mentioned, any first-class product made by a reputable manufacturer may be submitted for the Engineer's review.
- C. Where two or more names are given as approved manufacturers of equivalents, the Contractor must use the specified item or one of the named equivalents which still must meet all of the performance characteristics of the basis of design make and model. Where one name only is used and is followed by the words "or approved equal", the Contractor must use the item named or he is required to apply for a substitution. Where one name only is used, the Contractor must use that item named.
- D. Where the Contractor proposes to deviate (provide an equivalent or request for substitution) from the equipment or materials as hereinafter specified, they are required to submit a request for substitution in writing. The Contractor shall state in their request whether it is a substitution or a non approved equivalent to that specified and the amount of credit or extra cost involved. The Base Bid shall be based on using the materials and equipment as specified with no exceptions.

## SPECIAL PROVISIONS

- E. Where the Contractor proposes to use an item of equipment other than specified or detailed on the Drawings which requires any redesign of the electrical layout, all such redesign and all new drawings and detailing required therefore shall be prepared by the Engineer of Record at the expense of the Contractor and at no additional cost to the Owner.
- F. Equipment, material or devices submitted for review as an “equivalent” shall meet the following requirements:
1. The equivalent shall have the same construction features such as, but not limited to:
    - a. Material thickness, gauge, weight, density, etc.
    - b. Welded, riveted, bolted, etc., construction
    - c. Finish, undercoating, corrosion protection
  2. The equivalent shall perform with the same or better operating efficiency.
  3. The equivalent shall be locally represented by the manufacturer for service, parts and technical information.
  4. The equivalent shall bear the same labels of performance certification as is applicable to the specified item, such as UL or NEMA labels.
- G. Equipment, material or devices submitted for review as a “substitution” shall meet the following requirements:
1. Submit electronic copy in pdf format of each request for substitution for consideration.
  2. Identify the product, or the fabrication or installation method to be replaced in each request. Include related Specification Section and Drawing numbers. Provide complete documentation showing compliance with the requirements for substitutions, and the following information, as appropriate:
    - a. Product Data, including Drawings and descriptions of products, fabrication and installation procedures.
    - b. Samples, where applicable or requested.
    - c. A detailed comparison of significant qualities may include elements such as size, weight, durability, performance and visual effect.
    - d. Coordination information, including a list of changes or modifications needed to other parts of the Work and to construction performed by the Owner and separate Contractors that will become necessary to accommodate the proposed substitution.
    - e. A statement indicating the substitution’s effect on the Contractor’s Construction Schedule compared to the schedule without approval of the substitution. Indicate the effect of the proposed substitution on overall Contract Time.
    - f. Cost information, including a proposal of the net change, if any in the Contract Sum.
    - g. Certification by the Contractor that the substitution proposed is equal-to or better in every significant respect to that required by the Contract Documents, and that it will perform adequately in the application indicated. Include the Contractor’s waiver of rights to additional payment or time that may subsequently become necessary because of the failure of the substitution to perform adequately.
    - h. Other Conditions: The Contractor’s substitution request will be received and considered by the Engineer when one or more of the following conditions are satisfied, as determined by the Engineer; otherwise requests will be returned without action except to record noncompliance with these requirements.
      - 1) The request is directly related to an “or equal” clause or similar language in the Contract Documents.
      - 2) The specified product or method of construction cannot be provided within the Contract Time. The request will not be considered if the product or

## SPECIAL PROVISIONS

method cannot be provided as a result of failure to pursue the Work promptly or coordinate activities properly.

- 3) A substantial advantage is offered the Owner, in terms of cost, time, energy conservation or other considerations of merit, after deducting offsetting responsibilities the Owner may be required to bear. Additional responsibilities for the Owner may include additional compensation to the Engineer for redesign and evaluation services, increased cost of other construction by the Owner or separate Contractors, and similar considerations.

### 1.10 SUBMITTAL PROCEDURES

- A. Provide Submittals in accordance with the requirements of Division 1 and as indicated in the following.
- B. Coordination: Coordinate preparation and processing of submittals with performance of construction activities. Transmit each submittal sufficiently in advance of performance of related construction activities to avoid delay.
  1. Coordinate each submittal with fabrication, purchasing, testing, delivery, other submittals and related activities that require sequential activity.
  2. Coordinate transmittal of different types of submittals for related elements of the Work so processing will not be delayed by the need to review submittals concurrently for coordination. The Engineer reserves the right to withhold action on a submittal requiring coordination with other submittals until related submittals are received.
- C. Submittal Preparation: Place a permanent label or title block on each submittal for identification. Indicate the name of the entity that prepared each submittal on the label or title block.
  1. Include the following information on the label for processing and recording action taken.
    - a. Project name.
    - b. Date.
    - c. Name and address of Engineer.
    - d. Name and address of Contractor.
    - e. Name and address of supplier.
    - f. Name of manufacturer.
    - g. Number and title of appropriate Specification Section.
    - h. Drawing number and detail references, as appropriate.
- D. Submittal Transmittal: Package each submittal appropriately for transmittal and handling. Transmit each submittal from Contractor to Engineer using a transmittal form. Submittals received from sources other than the Contractor will be returned without action. On the transmittal, record relevant information and requests for data. On the form, or separate sheet, record deviations from Contract Document requirements, including minor variations and limitations. Include Contractor's certification that information complies with Contract Document requirements.
- E. Except for submittals for record, information or similar purposes, where action and return is required or requested, the Engineer will review each submittal, mark to indicate action taken, and return promptly. Compliance with specified characteristics is the Contractor's responsibility.

## SPECIAL PROVISIONS

- F. Action Stamp: The Engineer will stamp each submittal with a uniform, self-explanatory action stamp. The stamp will be appropriately marked, to indicate the action taken.

### 1.11 COORDINATION WITH OTHER DIVISIONS

- A. All work shall be carried out in conjunction with other trades and full cooperation shall be given in order that all work may proceed with a minimum of delay and interference. Particular emphasis is placed on timely installation of major apparatus and furnishing other Contractors, especially the Contractor or Construction Manager, with information as to openings, chases, sleeves, bases, inserts, equipment locations, panels, etc., required by other trades.
- B. The Contractors are required to examine all of the Project Drawings and mutually arrange work so as to avoid interference with the work of other trades. In general, piping, and drainage lines take precedence over electrical conduits. The Engineer shall make final decisions regarding the arrangement of work which cannot be agreed upon by the Contractors.
- C. Where the work of the Contractor will be installed in close proximity to or will interfere with work of other trades, the Contractors will cooperate in working out space conditions to make a satisfactory adjustment.
- D. If the work under Section is installed before coordinating with other Divisions or Sections or so as to cause interference with work of other Sections, the necessary changes to correct the condition shall be made by the Contractor causing the interference without extra charge to the Owner.

### 1.12 WORKMANSHIP

- A. Service Support: The equipment items shall be supported by service organizations which are reasonably convenient to the equipment installation in order to render satisfactory service to the equipment on a regular and emergency basis during the warranty period of the contract.
- B. Modification of References: In each of the publications referred to herein, consider the advisory provisions to be mandatory, as though the word, "shall" had been substituted for "should" wherever it appears.
- C. The Contractor shall furnish the services of an experienced superintendent who shall be constantly in charge of the installation of the work together with all skilled workmen, journeymen, electricians, helpers and laborers required to unload, transfer, erect, connect, adjust, start, operate and test each system.
- D. Unless otherwise specifically indicated on the Drawings or Specifications, all equipment and materials shall be installed with the acceptance of the Engineer and in accordance with the recommendations of the manufacturer. This includes the performance of such tests as the manufacturer recommends.
- E. All labor for installation of electrical systems shall be performed by experienced, skilled tradesmen under the supervision of a licensed journeyman foreman. All work shall be of a quality consistent with good trade practice and shall be installed in a neat, workmanlike manner. The Engineer reserves the right to reject any work which, in his opinion, has been installed in a

## SPECIAL PROVISIONS

substandard, dangerous or unserviceable manner. The Contractor shall replace said work in a satisfactory manner at no extra cost to the Owner.

### 1.13 PROTECTION OF MATERIALS AND EQUIPMENT

- A. Work under each Section shall include protecting the work and material of all other Sections from damage by work or workmen and shall include making good all damage thus caused.
- B. The Contractor shall be responsible for work and equipment until the project has been accepted by the Owner. Protect work against theft, injury or damage and carefully store material and equipment received on site which is not immediately installed. Close open ends of work with temporary covers or plugs during construction to prevent entry of foreign material.
- C. Work under each Section includes receiving, unloading, uncrating, storing, protecting, setting in place and completely connecting equipment supplied under each Section. Work under each Section shall also include exercising special care in handling and protecting equipment and fixtures, and shall include the cost of replacing any of the equipment and fixtures which are missing or damaged.
- D. Equipment and material stored on the job site shall be protected from the weather, vehicles, dirt and/or damage by workmen or machinery.

### 1.14 ADJUSTING AND TESTING

- A. After all the equipment and accessories to be furnished are in place, they shall be put in final adjustment and subjected to such operating tests so as to assure the Engineer that they are in proper adjustment and in satisfactory, permanent operating condition.

### 1.15 ACCEPTANCES

- A. The equipment, materials, workmanship, design and arrangement of all work installed under the Electrical Sections shall be subject to the review of the Engineer.
- B. If extensive or unacceptable delivery time is expected on a particular item of equipment specified, the Contractor shall notify the Owner and Engineer, in writing, within thirty (30) days of the awarding of the Contract. In such instances, deviations may be made pending acceptance by the Engineer or the Owner's representative.
- C. Where any specific material, process or method of construction or manufacturing article is specified by reference to the catalog number of a manufacturer, the Specifications are to be used as a guide and are not intended to take precedence over the basic duty and performance specified or noted on the Drawings. In all cases, the Contractor shall verify the duty specified with the specific characteristics of the equipment offered for review. Equipment characteristics are to be used as mandatory requirements where the Contractor proposes to use an acceptable equivalent.
- D. If material or equipment is installed before it is reviewed and/or approved, the Contractor shall be liable for its removal and replacement at no extra charge to the Owner if, in the opinion of

## SPECIAL PROVISIONS

the Engineer, the material or equipment does not meet the intent of, or standard of quality implied by, the Drawings and Specifications.

- E. Failure on the part of the Engineer to reject shop drawings or to reject work in progress shall not be interpreted as acceptance of work not in conformance with the Drawings and/or Specifications. Work not in conformance with the Drawings and/or Specifications shall be corrected whenever it is discovered.

### 1.16 RECORD DRAWINGS

- A. General: Do not use record documents for construction purposes; protect from deterioration and loss in a secure, fire-resistive location; provide access to record documents for the Engineer's reference during normal working hours.
- B. Record Drawings: Maintain a clean, undamaged set of Contract Drawings. Mark the set to show the actual installation where the installation varies substantially from the Work as originally shown. Mark whichever drawing is most capable of showing condition fully and accurately. Give particular attention to concealed elements that would be difficult to measure and record at a later date.
  - 1. Mark record sets with red erasable pencil; use other color to distinguish between variations in separate categories of the Work.
  - 2. Mark new information that is important to the Owner, but was not shown on Contract Drawings.
  - 3. Note related Change Order numbers where applicable.
  - 4. Organize record drawing sheets into manageable sets, bind with durable paper cover sheets, and print suitable titles, dates and other identification of the cover of each set.

### 1.17 WARRANTIES AND BONDS

- A. The following general administrative and procedural requirements for warranties and bonds required by the Contract Documents, including manufacturers standard warranties on products and special warranties are to be included:
  - 1. General close-out requirements included in Section "CLOSEOUT PROCEDURES."
  - 2. Certifications and other commitments and agreements for continuing services to Owner are specified elsewhere in the Contract Documents.
- B. Disclaimers and Limitations: Manufacturer's disclaimers and limitations on product warranties do not relieve the Contractor of the warranty on the Work that incorporates the products, nor does it relieve suppliers, manufacturers, and subcontractors required to countersign special warranties with the Contractor.
- C. Separate Prime Contracts: Each prime Contractor is responsible for warranties related to its own Contract.

### 1.18 WARRANTY REQUIREMENTS

- A. Related Damages and Losses: When correcting warranted Work that has failed, remove and replace other Work that has been damaged as a result of such failure or that must be removed and replaced to provide access for correction of warranted Work.
- B. Reinstatement of Warranty: When Work covered by a warranty has failed and been

## SPECIAL PROVISIONS

corrected by replacement or rebuilding, reinstate the warranty by written endorsement. The reinstated warranty shall be equal to the original warranty with an equitable adjustment for depreciation.

- C. Replacement Cost: Upon determination that Work covered by a warranty has failed, replace or rebuild the Work to an acceptable condition complying with requirements of Contract Documents. The Contractor is responsible for the cost of replacing or rebuilding defective Work regardless of whether the Owner has benefited from use of the Work through a portion of its anticipated useful service life.
- D. Owner's Recourse: Written warranties made to the Owner are in addition to implied warranties, and shall not limit the duties, obligations, right and remedies otherwise available under law, nor shall warranty periods be interpreted as limitation on time in which the Owner can enforce such other duties, obligations, rights, or remedies.
- E. Rejection of Warranties: The Owner reserves the right to reject warranties and to limit selections of products with warranties not in conflict with requirements of the Contract Documents.
- F. The Owner reserves the right to refuse to accept the Work for the Project where a special warranty, certification, or similar commitment is required on such Work or part of the Work, until evidence is presented that entitles required to countersign such commitments are willing to do so.
- G. Manufacturer's warranties shall not start until the date of Substantial Completion or, until all aspects of the commissioning of the respective system are complete and accepted by the Commissioning Authority and the Owner, whichever date is later. The contractor responsible for this section shall include in their base bid any additional cost for extending manufacturer's warranties until the date of Substantial Completion or, until all aspects of the commissioning of the respective system are complete and accepted by the Commissioning Authority and the Owner, whichever date is later.
- H. When as designated portion of the Work is completed and occupied or used by the Owner, by separate agreement with the Contractor during the construction period, submit properly executed warranties to the Engineer within fifteen days of completion of that designated portion of the Work.
- I. When a special warranty is required to be executed by the Contractor, or the Contractor and a subcontractor, supplier or manufacturer, prepare a written document that contains appropriate terms and identification, ready for execution by the required parties. Submit a draft to the Owner through the Engineer for approval prior to final execution.
  - 1. Refer to individual Sections of Divisions 2 through 32 for specific content requirements, and particular requirements for submittal of special warranties.
- J. Form of Submittal: At Final Completion compile two copies of each required warranty and bond properly executed by the Contractor, or by the Contractor, subcontractor, supplier, or manufacturer. Organize the warranty documents into an orderly sequence based on the table of contents of the Project Manual.

## SPECIAL PROVISIONS

- K. Bind warranties and bonds in heavy-duty, commercial quality, durable 3-ring vinyl covered losses-leaf binders, thickness as necessary to accommodate contents, and sized to receive 8-1/2" by 11" paper.
  - 1. Provide heavy paper dividers with celluloid covered tabs for each separate warranty. Mark the tab to identify the product or installation. Provide a typed description of the product or installation, including the name of the product, and the name, address and telephone number of the installer.
  - 2. Identify each binder on the front and the spine with the typed or printed title "WARRANTIES AND BONDS," the Project title or name, and the name of the Contractor.
  - 3. When operating and maintenance manuals are required for warranted construction, provide additional copies of each required warranty, as necessary, for inclusion in each required manual.
  
- L. All warranties shall clearly present the start and end dates. Dates shall meet specified requirements of corresponding specification sections. Dates shall also meet requirements of DIVISION 1 – WARRANTIES.

### 1.19 GUARANTEES

- A. The Contractor shall guarantee all material and workmanship under these Specifications and the Contract for a period of one (1) year from the date of final acceptance by Owner. During this guarantee period, all defects developing through faulty equipment, materials or workmanship shall be corrected or replaced immediately by this Contractor without expense to the Owner. Such repairs or replacement shall be made to the Engineers satisfaction.
  
- B. Contractor shall provide name, address, and phone number of all contractors and subcontractors and associated equipment they provided.

### 1.20 PROJECT CLOSE-OUT

- A. Submit specific warranties, final certifications and similar documents.

### **PART 2 - PRODUCTS (Not Used)**

### **PART 3 - EXECUTION (Not Used)**

## END OF SECTION

*Add the following Section:*

## **SECTION 260519 - LOW-VOLTAGE ELECTRICAL POWER CONDUCTORS AND CABLES**

### **PART 1 – GENERAL**

#### 1.1 SUMMARY

- A. Section Includes:



## SPECIAL PROVISIONS

1. Copper wire rated 600 V or less.
2. Connectors, splices, and terminations rated 600 V and less.

### 1.2 ACTION SUBMITTALS

- A. Product Data: For each type of product.

## PART 2 - PRODUCTS

### 2.1 COPPER WIRE

- A. Description: Flexible, insulated and uninsulated, drawn copper current-carrying conductor with an overall insulation layer or jacket, or both, rated 600 V or less.
- B. Manufacturers: Subject to compliance with requirements, available manufacturers offering products that may be incorporated into the Work include, but are not limited to the following:
  1. Cerro Wire LLC.
  2. Okonite Company (The).
  3. Southwire Company.
- C. Standards:
  1. Listed and labeled as defined in NFPA 70, by a qualified testing agency, and marked for intended location and use.
  2. Conductor and Cable Marking: Comply with wire and cable marking according to UL's "Wire and Cable Marking and Application Guide."
- D. Conductors: Copper, complying with ASTM B3 for bare annealed copper and with ASTM B8 for stranded conductors.
- E. Conductor Insulation:
  1. Type THWN-2: Comply with UL 83.

## PART 3 - EXECUTION

### 3.1 CONDUCTOR MATERIAL APPLICATIONS

- A. Feeders and Branch Circuits:
  1. Copper; stranded.

### 3.2 CONDUCTOR INSULATION AND MULTICONDUCTOR CABLE APPLICATIONS AND WIRING METHODS

- A. Feeders: Type THHN/THWN-2, single conductors in raceway.
- B. Branch Circuits: Type THHN/THWN-2, single conductors in raceway.

## SPECIAL PROVISIONS

### 3.3 INSTALLATION OF CONDUCTORS AND CABLES

- A. Complete raceway installation between conductor and cable termination points according to Section 260533 "Raceways and Boxes for Electrical Systems" prior to pulling conductors and cables.
- B. Use manufacturer-approved pulling compound or lubricant where necessary; compound used must not deteriorate conductor or insulation. Do not exceed manufacturer's recommended maximum pulling tensions and sidewall pressure values.
- C. Use pulling means, including fish tape, cable, rope, and basket-weave wire/cable grips, that will not damage cables or raceway.
- D. Support cables according to Section 260529 "Hangers and Supports for Electrical Systems".

### 3.4 CONNECTIONS

- A. Tighten electrical connectors and terminals according to manufacturer's published torque-tightening values. If manufacturer's torque values are not indicated, use those specified in UL 486A-486B.
- B. Make splices, terminations, and taps that are compatible with conductor material.
- C. Wiring at Outlets: Install conductor at each outlet, with at least 12 inch (300 mm) of slack.

### 3.5 IDENTIFICATION

- A. Identify and color-code conductors and cables according to Section 260553 "Identification for Electrical Systems".
- B. Identify each spare conductor at each end with identity number and location of other end of conductor, and identify as spare conductor.

## END OF SECTION

*Add the following Section:*

### SECTION 260526 - GROUNDING AND BONDING FOR ELECTRICAL SYSTEMS

#### PART 1 – GENERAL

##### 1.1 SUMMARY

- A. Section includes grounding and bonding systems and equipment.

##### 1.2 ACTION SUBMITTALS

- A. Product Data: For each type of product.

## SPECIAL PROVISIONS

### PART 2 – PRODUCTS

#### 2.1 SYSTEM DESCRIPTION

- A. Electrical Components, Devices, and Accessories: Listed and labeled as defined in NFPA 70, by a qualified testing agency, and marked for intended location and application.
- B. Comply with UL 467 for grounding and bonding materials and equipment.

#### 2.2 MANUFACTURERS

- A. Manufacturers: Subject to compliance with requirements, available manufacturers offering products that may be incorporated into the Work include, but are not limited to the following:
  - 1. Burndy; Hubbell Incorporated, Construction and Energy.
  - 2. ERICO; nVent.
  - 3. ILSCO.
  - 4. O-Z/Gedney; Emerson Electric Co., Automation Solutions, Appleton Group.

#### 2.3 CONDUCTORS

- A. Insulated Conductors: Copper wire or cable insulated for 600 V unless otherwise required by applicable Code or authorities having jurisdiction.
- B. Bare Copper Conductors:
  - 1. Stranded Conductors: ASTM B8.
  - 2. Bonding Conductor: No. 4 or No. 6 AWG, stranded conductor.

#### 2.4 CONNECTORS

- A. Listed and labeled by an NRTL acceptable to authorities having jurisdiction for applications in which used and for specific types, sizes, and combinations of conductors and other items connected.
- B. Welded Connectors: Exothermic-welding kits of types recommended by kit manufacturer for materials being joined and installation conditions.
- C. Mechanical-Type Bus-Bar Connectors: Cast silicon bronze, solderless compression-type wire terminals, and long-barrel, two-bolt connection to ground bus bar.
- D. Conduit Hubs: Mechanical type, terminal with threaded hub.

#### 2.5 GROUNDING ELECTRODES

- A. Ground Rods: Copper-clad steel; 3/4 inch by 10 ft. (19 mm by 3 m).

## SPECIAL PROVISIONS

### PART 3 – EXECUTION

#### 3.1 APPLICATIONS

- A. Conductor Terminations and Connections:
  - 1. Equipment Grounding Conductor Terminations: Bolted connectors.
  - 2. Underground Connections: Welded connectors.
  - 3. Connections to Ground Rods: Welded connectors.

#### 3.2 GROUNDING AT THE SERVICE

- A. Equipment grounding conductors and grounding electrode conductors must be connected to the ground bus. Install a main bonding jumper between the neutral and ground buses.

#### 3.3 EQUIPMENT GROUNDING

- A. Install insulated equipment grounding conductors with all feeders and branch circuits.

#### 3.5 INSTALLATION

- A. Grounding Conductors: Route along shortest and straightest paths possible unless otherwise indicated or required by Code. Avoid obstructing access or placing conductors where they may be subjected to strain, impact, or damage.
- B. Ground Rods: Drive rods until tops are 2 inch (50 mm) below final grade.
  - 1. Interconnect ground rods with grounding electrode conductor below grade and as otherwise indicated. Make connections without exposing steel or damaging coating if any.

#### 3.6 FIELD QUALITY CONTROL

- A. Tests and Inspections:
  - 1. After installing grounding system but before permanent electrical circuits have been energized, test for compliance with requirements.
  - 2. Inspect physical and mechanical condition. Verify tightness of accessible, bolted, electrical connections with a calibrated torque wrench according to manufacturer's written instructions.

### END OF SECTION

*Add the following Section:*

### SECTION 260533 - RACEWAYS AND BOXES FOR ELECTRICAL SYSTEMS

#### PART 1 – GENERAL

##### 1.1 SUMMARY

## SPECIAL PROVISIONS

- A. Section Includes:
  - 1. Metal conduits and fittings.
  - 2. Nonmetallic conduits and fittings.
  - 3. Handholes and boxes for exterior underground cabling.

### 1.2 ACTION SUBMITTALS

- A. Product Data: For each type of product.

## PART 2 - PRODUCTS

### 2.1 METAL CONDUITS AND FITTINGS

- A. Metal Conduit:
  - 1. Manufacturers: Subject to compliance with requirements, available manufacturers offering products that may be incorporated into the Work include, but are not limited to the following:
    - a. Allied Tube & Conduit; Atkore International.
    - b. Calconduit; Atkore International.
    - c. O-Z/Gedney; Emerson Electric Co., Automation Solutions, Appleton Group.
  - 2. Listing and Labeling: Metal conduits, tubing, and fittings shall be listed and labeled as defined in NFPA 70, by a qualified testing agency, and marked for intended location and application.
  - 3. GRC: Comply with ANSI C80.1 and UL 6.
- B. Metal Fittings: Comply with NEMA FB 1 and UL 514B.
  - 1. Listing and Labeling: Listed and labeled as defined in NFPA 70, by a qualified testing agency, and marked for intended location and application.
  - 2. Fittings, General: Listed and labeled for type of conduit, location, and use.
  - 3. Expansion Fittings: PVC or steel to match conduit type, complying with UL 651, rated for environmental conditions where installed, and including flexible external bonding jumper.
- C. Joint Compound for GRC: Approved, as defined in NFPA 70, by authorities having jurisdiction for use in conduit assemblies, and compounded for use to lubricate and protect threaded conduit joints from corrosion and to enhance their conductivity.

### 2.2 NONMETALLIC CONDUITS AND FITTINGS

- A. Nonmetallic Conduit:
  - 1. Manufacturers: Subject to compliance with requirements, available manufacturers offering products that may be incorporated into the Work include, but are not limited to the following:
    - a. CertainTeed Corporation; Saint-Gobain North America.

## SPECIAL PROVISIONS

- b. Champion Fiberglass, Inc.
  - c. Condux International, Inc.
  - d. Dura-Line Communications Group; Orbia Advance Corporation, S.A.B. de C.V.
- B. Listing and Labeling: Listed and labeled as defined in NFPA 70, by a qualified testing agency, and marked for intended location and application.
- 1. RNC: Type EPC-40-PVC, complying with NEMA TC 2 and UL 651 unless otherwise indicated.
- C. Nonmetallic Fittings:
- 1. Fittings, General: Listed and labeled for type of conduit, location, and use.
  - 2. Fittings for RNC: Comply with NEMA TC 3; match to conduit or tubing type and material.
  - 3. Solvents and Adhesives: As recommended by conduit manufacturer.

### 2.3 HANDHOLES AND BOXES FOR EXTERIOR UNDERGROUND WIRING

- A. General Requirements for Handholes and Boxes:
- 1. Boxes and handholes for use in underground systems shall be designed and identified as defined in NFPA 70, for intended location and application.
  - 2. Boxes installed in wet areas shall be listed and labeled as defined in NFPA 70, by a qualified testing agency, and marked for intended location and application.
  - 3. Comply with City and Borough of Juneau Standard 119A.

## PART 3 - EXECUTION

### 3.1 RACEWAY APPLICATION

- A. Outdoors: Apply raceway products as specified below unless otherwise indicated:
- 1. Exposed Conduit: GRC.
  - 2. Underground Conduit: RNC, Type EPC-40-PVC, direct buried.
- B. Minimum Raceway Size: 3/4-inch (21-mm) trade size.
- C. Raceway Fittings: Compatible with raceways and suitable for use and location.
- 1. Rigid Steel Conduit: Use threaded rigid steel conduit fittings unless otherwise indicated. Comply with NEMA FB 2.10.

### 3.2 INSTALLATION

- A. Comply with requirements in Section 260529 "Hangers and Supports for Electrical Systems" for hangers and supports.
- B. Comply with NECA 1 and NECA 101 for installation requirements except where requirements on Drawings or in this article are stricter.

## SPECIAL PROVISIONS

- C. Arrange stub-ups so curved portions of bends are not visible above finished grade.
- D. Install no more than the equivalent of three 90-degree bends in any conduit run. Support within 12 inches (300 mm) of changes in direction.
- E. Make bends in raceway using large-radius preformed ells. Field bending shall be according to NFPA 70 minimum radii requirements. Use only equipment specifically designed for material and size involved.
- F. Threaded Conduit Joints, Exposed to Wet, Damp, Corrosive, or Outdoor Conditions: Apply listed compound to threads of raceway and fittings before making up joints. Follow compound manufacturer's written instructions.
- G. Coat field-cut threads on PVC-coated raceway with a corrosion-preventing conductive compound prior to assembly.
- H. Raceway Terminations at Locations Subject to Moisture or Vibration: Use insulating bushings to protect conductors including conductors smaller than No. 4 AWG.
- I. Terminate threaded conduits into threaded hubs or with locknuts on inside and outside of boxes or cabinets. Install bushings on conduits up to 1-1/4-inch (35-mm) trade size and insulated throat metal bushings on 1-1/2-inch (41-mm) trade size and larger conduits terminated with locknuts. Install insulated throat metal grounding bushings on service conduits.
- J. Install pull wires in empty raceways. Use polypropylene or monofilament plastic line with not less than 200-lb (90-kg) tensile strength. Leave at least 12 inches (300 mm) of slack at each end of pull wire. Cap underground raceways designated as spare above grade alongside raceways in use.

### 3.3 INSTALLATION OF UNDERGROUND CONDUIT

- A. Direct-Buried Conduit:
  - 1. Excavate trench bottom to provide firm and uniform support for conduit. Prepare trench bottom as specified in Section 312000 "Earth Moving" for pipe less than 6 inches (150 mm) in nominal diameter.
  - 2. Install backfill as specified in Section 312000 "Earth Moving."
  - 3. After installing conduit, backfill and compact. Start at tie-in point, and work toward end of conduit run, leaving conduit at end of run free to move with expansion and contraction as temperature changes during this process. Firmly hand tamp backfill around conduit to provide maximum supporting strength. After placing controlled backfill to within 12 inches (300 mm) of finished grade, make final conduit connection at end of run and complete backfilling with normal compaction as specified in Section 312000 "Earth Moving."
  - 4. Install manufactured duct elbows for stub-up at poles and equipment.
  - 5. Underground Warning Tape: Comply with requirements in Section 260553 "Identification for Electrical Systems."

## **SPECIAL PROVISIONS**

### 3.4 INSTALLATION OF UNDERGROUND HANDHOLES

- A. Install handholes and boxes level and plumb and with orientation and depth coordinated with connecting conduits to minimize bends and deflections required for proper entrances.
- B. Unless otherwise indicated, support units on a level bed of crushed stone or gravel, graded from 1/2-inch (12.5-mm) sieve to No. 4 (4.75-mm) sieve and compacted to same density as adjacent undisturbed earth.
- C. Elevation: In paved areas, set so cover surface will be flush with finished grade. Set covers of other enclosures 1 inch (25 mm) above finished grade.

### 3.5 PROTECTION

- A. Protect coatings, finishes, and cabinets from damage and deterioration.
  - 1. Repair damage to galvanized finishes with zinc-rich paint recommended by manufacturer.

## **END OF SECTION**

*Add the following Section:*

## **SECTION 260553 - IDENTIFICATION FOR ELECTRICAL SYSTEMS**

### **PART 1 – GENERAL**

#### 1.1 RELATED DOCUMENTS

- A. Drawings and general provisions of the Contract, including General and Supplementary Conditions and Division 01 Specification Sections, apply to this Section.

#### 1.2 SUMMARY

- A. Section Includes:
  - 1. Color requirements for conductors.
  - 2. Labels.
  - 3. Tapes.
  - 4. Cable ties.

### **PART 2 - PRODUCTS**

#### 2.1 PERFORMANCE REQUIREMENTS

- A. Comply with NFPA 70.
- B. Comply with ANSI Z535.4 for safety signs and labels.



## SPECIAL PROVISIONS

### 2.2 COLOR AND LEGEND REQUIREMENTS

- A. Color-Coding for Phase and Voltage-Level Identification, 600 V or Less: Use colors listed below for ungrounded feeder and branch-circuit conductors.
  - 1. Color shall be factory applied or field applied for sizes larger than No. 8 AWG if authorities having jurisdiction permit.
  - 2. Colors for 240/120-V, 1-phase Circuits:
    - a. Phase A: Black.
    - b. Phase B: Red.
    - c. Neutral: White
  - 3. Color for Equipment Grounds: Green.

### 2.3 TAPES

- A. Marker Tapes: Vinyl or vinyl-cloth, self-adhesive wraparound type, with circuit identification legend machine printed by thermal transfer or equivalent process.
- B. Underground-Line Warning Tape:
  - 1. Tape:
    - a. Recommended by manufacturer for the method of installation and suitable to identify and locate underground electrical lines.
    - b. Printing on tape shall be permanent and shall not be damaged by burial operations.
    - c. Tape material and ink shall be chemically inert and not subject to degradation when exposed to acids, alkalis, and other destructive substances commonly found in soils.
  - 2. Color and Printing:
    - a. Comply with ANSI Z535.1, ANSI Z535.2, ANSI Z535.3, ANSI Z535.4, and ANSI Z535.5.
    - b. Inscriptions for Red-Colored Tapes: "ELECTRIC LINE, HIGH VOLTAGE".

### 2.4 CABLE TIES

- A. General-Purpose Cable Ties: Fungus inert, self-extinguishing, one piece, self-locking, and Type 6/6 nylon.
  - 1. Minimum Width: 3/16 inch (5 mm).
  - 2. Tensile Strength at 73 Deg F (23 Deg C) according to ASTM D638: 12,000 psi (82.7 MPa).
  - 3. Temperature Range: Minus 40 to plus 185 deg F (Minus 40 to plus 85 deg C).
  - 4. Color: Black, except where used for color-coding.

## SPECIAL PROVISIONS

### PART 3 - EXECUTION

#### 3.1 INSTALLATION

- A. Verify identity of each item before installing identification products.
- B. Coordinate identification with Project Drawings, manufacturer's wiring diagrams, and operation and maintenance manual.
- C. Self-Adhesive Identification Products: Before applying electrical identification products, clean substrates of substances that could impair bond, using materials and methods recommended by manufacturer of identification product.
- D. Self-Adhesive Vinyl Tape: Secure tight to surface at a location with high visibility and accessibility.
  - 1. Field-Applied, Color-Coding Conductor Tape: Apply in half-lapped turns for a minimum distance of 6 inches (150 mm) where splices or taps are made. Apply last two turns of tape with no tension to prevent possible unwinding.
- E. Underground Line Warning Tape:
  - 1. During backfilling of trenches, install continuous underground-line warning tape directly above cable or raceway at 6 to 8 inches (150 to 200 mm) below finished grade. Use multiple tapes where width of multiple lines installed in a common trench exceeds 16 inches (400 mm) overall.
  - 2. Install underground-line warning tape for direct-buried cables and cables in raceways.
- F. Cable Ties: General purpose, for attaching tags, except as listed below:
  - 1. Outdoors: UV-stabilized nylon.

#### 3.2 IDENTIFICATION SCHEDULE

- A. Power-Circuit Conductor Identification, 600 V or Less: For conductors in vaults, pull and junction boxes, manholes, and handholes, use self-adhesive wraparound labels to identify the phase.
- B. Locations of Underground Lines: Underground-line warning tape for power and lighting.

### END OF SECTION

*Add the following Section:*

### SECTION 262816 - ENCLOSED SWITCHES AND CIRCUIT BREAKERS

#### PART 1 – GENERAL

##### 1.1 SUMMARY

## SPECIAL PROVISIONS

- A. Section Includes:
  - 1. Fusible switches.
  - 2. Enclosures.
- 1.2 ACTION SUBMITTALS
  - A. Product Data: For each type of enclosed switch, circuit breaker, accessory, and component indicated. Include nameplate ratings, dimensioned elevations, sections, weights, and manufacturers' technical data on features, performance, electrical characteristics, ratings, accessories, and finishes.
- 1.3 CLOSEOUT SUBMITTALS
  - A. Operation and maintenance data.
- 1.4 WARRANTY
  - A. Manufacturer's Warranty: Manufacturer and Installer agree to repair or replace components that fail in materials or workmanship within specified warranty period.
    - 1. Warranty Period: One year(s) from date of Substantial Completion.

### PART 2 - PRODUCTS

- 2.1 GENERAL REQUIREMENTS
  - A. Electrical Components, Devices, and Accessories: Listed and labeled as defined in NFPA 70, by an NRTL, and marked for intended location and application.
  - B. Comply with NFPA 70.
- 2.2 FUSIBLE SWITCHES
  - A. Manufacturers: Subject to compliance with requirements, available manufacturers offering products that may be incorporated into the Work include, but are not limited to the following:
    - 1. ABB, Electrification Business.
    - 2. Eaton.
    - 3. Siemens Industry, Inc., Energy Management Division.
    - 4. Square D; Schneider Electric USA.
  - B. Type HD, Heavy Duty:
    - 1. Single throw.
    - 2. 240-V ac.
    - 3. UL 98 and NEMA KS 1, horsepower rated, with clips or bolt pads to accommodate indicated fuses.
    - 4. Lockable handle with capability to accept three padlocks, and interlocked with cover in closed position.

## SPECIAL PROVISIONS

### C. Accessories:

1. Equipment Ground Kit: Internally mounted and labeled for copper and aluminum ground conductors.
2. Neutral Kit: Internally mounted; insulated, capable of being grounded and bonded; labeled for copper and aluminum neutral conductors.
3. Service-Rated Switches: Labeled for use as service equipment.

### 2.3 ENCLOSURES

- A. Enclosed Switches and Circuit Breakers: UL 489, NEMA KS 1, NEMA 250, and UL 50, to comply with environmental conditions at installed location.
- B. Enclosure Finish: The enclosure shall be NEMA 250 Type 4-4X stainless steel.
- C. Conduit Entry: NEMA 250 Types 4, 4X, and 12 enclosures shall contain no knockouts. NEMA 250 Types 7 and 9 enclosures shall be provided with threaded conduit openings in both endwalls.
- D. Enclosures designated as NEMA 250 Type 4, 4X stainless steel, 12, or 12K shall have a dual cover interlock mechanism to prevent unintentional opening of the enclosure cover when the circuit breaker is ON and to prevent turning the circuit breaker ON when the enclosure cover is open.

## PART 3 - EXECUTION

### 3.1 ENCLOSURE ENVIRONMENTAL RATING APPLICATIONS

- A. Enclosed Switches and Circuit Breakers: Provide enclosures at installed locations with the following environmental ratings.
  1. Outdoor Locations: NEMA 250, Type 4X.

### 3.2 INSTALLATION

- A. Coordinate layout and installation of switches, circuit breakers, and components with equipment served and adjacent surfaces. Maintain required workspace clearances and required clearances for equipment access doors and panels.
- B. Install fuses in fusible devices.
- C. Comply with NFPA 70 and NECA 1.

### 3.3 IDENTIFICATION

- A. Comply with requirements in Section 260553 "Identification for Electrical Systems."
  1. Identify field-installed conductors, interconnecting wiring, and components; provide warning signs.
  2. Label each enclosure with engraved metal or laminated-plastic nameplate.

## SPECIAL PROVISIONS

### 3.4 FIELD QUALITY CONTROL

#### A. Tests and Inspections for Switches:

##### 1. Visual and Mechanical Inspection:

- a. Inspect physical and mechanical condition.
- b. Inspect anchorage, alignment, grounding, and clearances.
- c. Verify that the unit is clean.
- d. Verify blade alignment, blade penetration, travel stops, and mechanical operation.
- e. Verify that fuse sizes and types match the Specifications and Drawings.
- f. Verify that each fuse has adequate mechanical support and contact integrity.
- g. Inspect bolted electrical connections for high resistance using one of the two following methods:
  - 1) Use a low-resistance ohmmeter.
    - a) Compare bolted connection resistance values to values of similar connections. Investigate values that deviate from those of similar bolted connections by more than 50 percent of the lowest value.
  - 2) Verify tightness of accessible bolted electrical connections by calibrated torque-wrench method in accordance with manufacturer's published data or NETA ATS Table 100.12.
    - a) Bolt-torque levels shall be in accordance with manufacturer's published data. In the absence of manufacturer's published data, use NETA ATS Table 100.12.
- h. Verify that operation and sequencing of interlocking systems is as described in the Specifications and shown on the Drawings.
- i. Verify correct phase barrier installation.
- j. Verify lubrication of moving current-carrying parts and moving and sliding surfaces.

- B. Enclosed switches and circuit breakers will be considered defective if they do not pass tests and inspections.

**END OF SECTION**

***END OF SPECIAL PROVISIONS***

**SHEET INDEX**

SHEET No.	DESCRIPTION
C001	COVER SHEET
C002	GENERAL NOTES, ABBREVIATIONS AND SYMBOLS
C003	SURVEY CONTROL MAP
C004	SUMMARY TABLES
C100	TYPICAL SECTIONS
C101	CONSTRUCTION DETAILS
C102	CONSTRUCTION DETAILS
C103	CORROSION PROTECTION DETAILS
C200	PLAN - TONGASS BLVD. TRINITY DRIVE TO STA "T" 13+00
C201	PLAN - TONGASS BLVD. STA "T" 13+00 TO STA "T" 16+00
C202	PLAN - TONGASS BLVD. STA "T" 16+00 TO STA "T" 18+58
C203	PLAN - TONGASS BLVD. STA "T" 18+58 TO EOP
C300	PROFILE - TONGASS BLVD. TRINITY DRIVE TO STA "T" 16+00
C301	PROFILE - TONGASS BLVD. STA "T" 16+00 TO EOP
C400	PAVEMENT AND GUTTER LAYOUT - TONGASS BLVD. TRINITY DRIVE TO STA "T" 13+00
C401	PAVEMENT AND GUTTER LAYOUT - TONGASS BLVD. STA "T" 13+00 TO STA "T" 16+00
C402	PAVEMENT AND GUTTER LAYOUT - TONGASS BLVD. STA "T" 16+00 TO STA "T" 18+58
C403	PAVEMENT AND GUTTER LAYOUT - TONGASS BLVD. STA "T" 18+58 TO EOP
C500	SIGNING & STRIPING PLAN
E001	LEGEND AND TABLES
E200	ELECTRICAL PLAN TRINITY DRIVE TO STA "T" 16+00
E201	ELECTRICAL PLAN STA "T" 16+00 TO EOP
E300	SINGLE LINE DIAGRAM AND DETAILS

# TONGASS BOULEVARD RECONSTRUCTION PHASE I

## CBJ CONTRACT No. BE21-150

### CITY & BOROUGH OF JUNEAU, ALASKA

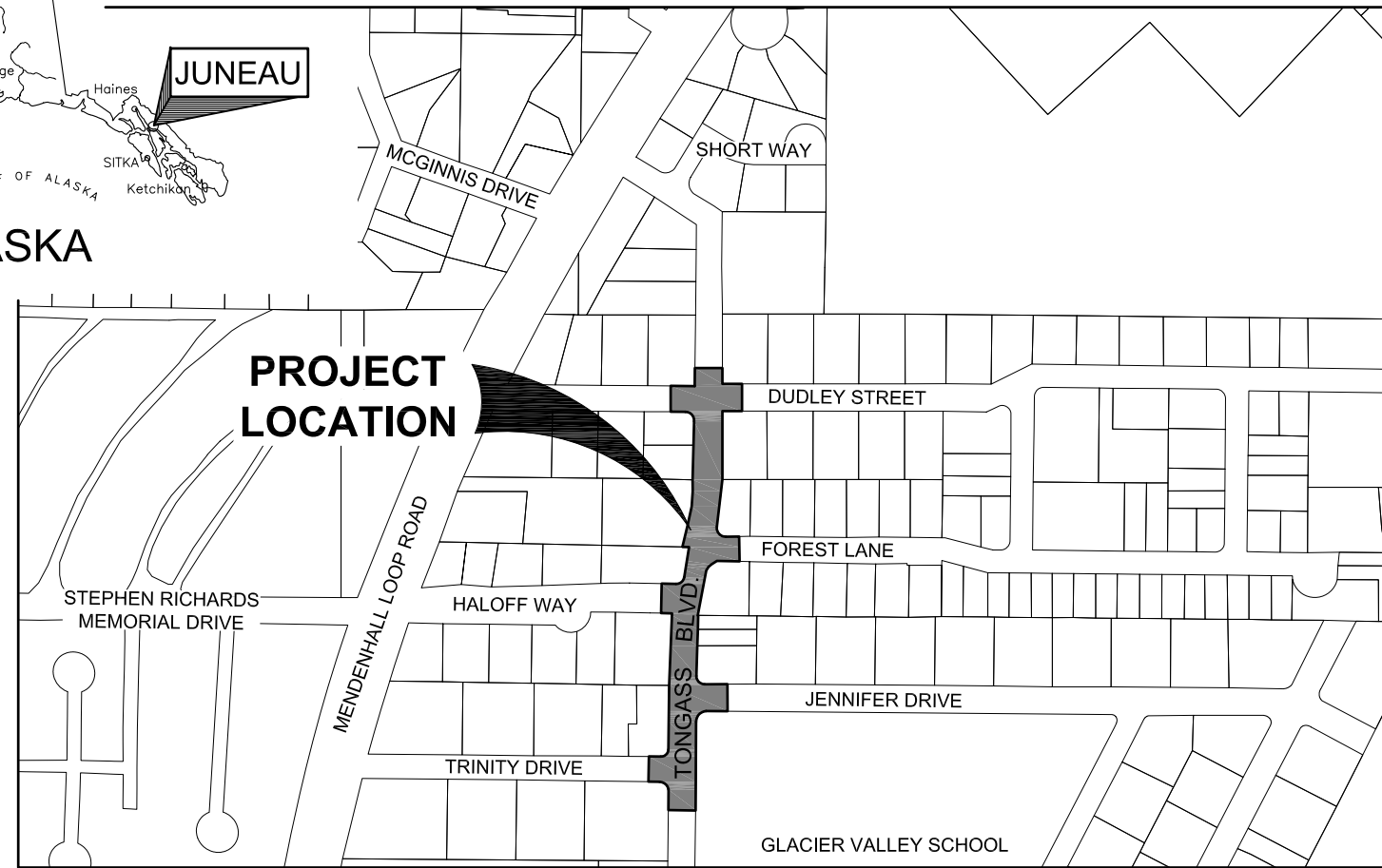
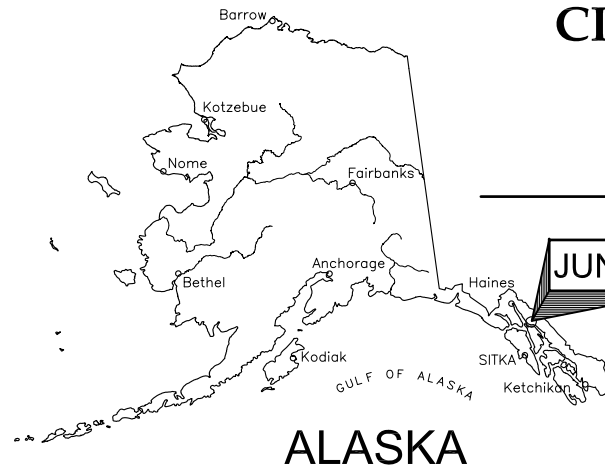

**PROJECT LOCATION MAP**

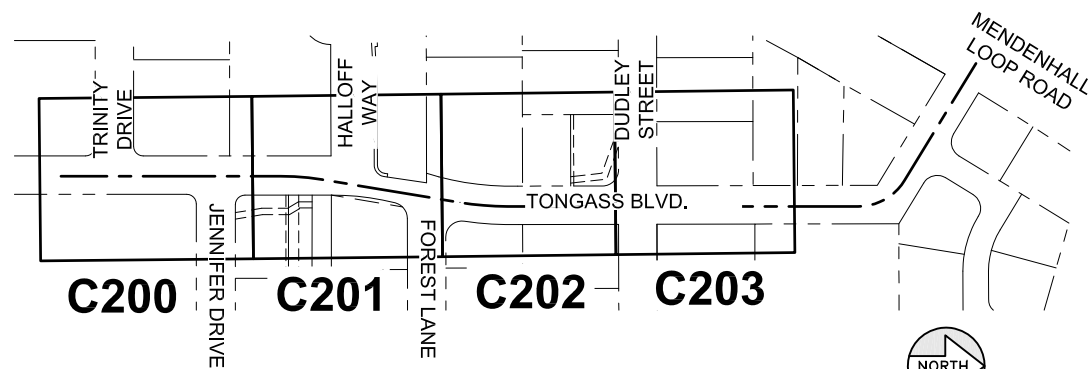
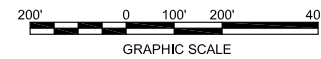

**SHEET KEY MAP**

N.T.S.

P:\2020\202323JN-CBJ\_Tongass\CC001.cov\202323JN.dwg PLOT: April 07, 2021 10:45:39am

DESIGN	KAP
DRAWN	JMK
CHECK	JMP
APPROVED	JMP
FILE:	

No.	DATE	REVISION

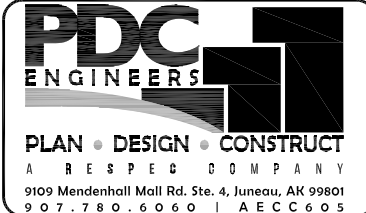

**TONGASS BOULEVARD  
RECONSTRUCTION  
PHASE I**  
CBJ CONTRACT No. BE21-150  
CITY & BOROUGH OF JUNEAU, ALASKA

**COVER SHEET**

DATE:	Apr 07, 2021
PDC No.	20232JN
SHEET	C001

## GENERAL CONSTRUCTION NOTES

1. CBJ ENGINEERING STANDARD DETAILS BOOK FOR CIVIL ENGINEERING PROJECTS AND SUBDIVISION IMPROVEMENTS DATED AUGUST, 2011 AND CBJ ENGINEERING STANDARD SPECIFICATIONS DATED DECEMBER, 2003 ARE MADE A PART OF THIS CONTRACT, WITH CURRENT REVISIONS AS APPLICABLE.
2. LARGE BOULDERS, HARDPAN, STUMPS, LOGS, ORGANICS AND GROUNDWATER MAY BE ENCOUNTERED AT VARIOUS DEPTHS DURING TRENCHING, DITCHING AND ROADWAY EXCAVATION OPERATIONS. THESE MATERIALS SHALL BE DISPOSED OF AS REQUIRED BY THE ENGINEER.
3. GRADES AND ALIGNMENTS SHOWN ON THESE PLANS ARE SUBJECT TO MINOR REVISIONS AS APPROVED BY THE ENGINEER.
4. LOCATION OF WATER SYSTEM IMPROVEMENTS, SANITARY SEWER MANHOLES, STORM DRAIN STRUCTURES, PIPING AND PIPE LENGTHS ARE SUBJECT TO MINOR REVISIONS AS APPROVED BY THE ENGINEER.
5. CONNECTIONS TO EXISTING SIDE STREETS AND DRIVEWAYS ARE APPROXIMATE AND SHALL BE FIELD VERIFIED BY THE CONTRACTOR PRIOR TO CONSTRUCTION.
6. LOCATIONS OF EXISTING UNDERGROUND SEWER, WATER, TELEPHONE, CABLE TELEVISION, AND POWER UTILITIES SHOWN ON THESE PLANS WERE DERIVED FROM CBJ AS-BUILTS OR FIELD LOCATES. ACTUAL LOCATIONS MAY VARY FROM THOSE SHOWN. THE CONTRACTOR IS RESPONSIBLE FOR LOCATING, PROTECTING AND MAINTAINING THE UTILITIES THROUGHOUT THE CONSTRUCTION OF THIS PROJECT. ANY DAMAGE RESULTING TO THESE UNDERGROUND UTILITIES DURING CONSTRUCTION SHALL BE PAID FOR BY THE CONTRACTOR AND SHALL BE CONSIDERED INCIDENTAL TO THE CONTRACT. CALL "DIAL BEFORE YOU DIG" @ 586-1333 FOR UNDERGROUND UTILITY LOCATES AND 811 ALASKA DIG LINE FOR ACS AND GCI PRIOR TO ANY EXCAVATION ACTIVITIES.
7. CONTRACTOR SHALL ASSURE GARBAGE PICKUP, DAILY MAIL SERVICE, FUEL AND SERVICE DELIVERIES WILL BE UNINTERRUPTED TO ALL RESIDENTS AFFECTED BY THIS PROJECT.
8. PROPERTY LINE LOCATIONS USED IN THESE PLANS WERE DERIVED FROM RECORD PLATS AND DO NOT REPRESENT A SUBDIVISION BOUNDARY SURVEY.
9. ALL SIGN INSTALLATIONS OR RELOCATIONS SHALL BE PERFORMED ACCORDING TO THE "MANUAL ON UNIFORM TRAFFIC CONTROL DEVICES" (M.U.T.C.D.) WITH THE ALASKA SUPPLEMENT.
10. THE CONTRACTOR SHALL DELIVER ALL ASPHALT PAVEMENT REMOVED FROM THIS PROJECT TO A STOCKPILE AREA IN THE CBJ LEMON CREEK PIT TO BE DESIGNATED BY THE ENGINEER. CONTACT THE CBJ PIT MANAGER, MICHAEL EICH, 586-0874, FOR THE EXACT LOCATION OF THE STOCKPILE AREA.
11. ALL ITEMS DESIGNATED TO BE REMOVED SHALL BE DISPOSED OF AT AN APPROVED DISPOSAL SITE, EXCEPT AS NOTED IN THE CONTRACT DOCUMENTS.
12. PROVIDE KNOCKOUTS IN PRECAST STORM DRAIN STRUCTURES FOR ALL PIPES SHOWN ON THE PLANS.
13. ONLY HORIZONTAL ELBOW FITTINGS (BENDS) ARE SHOWN ON THE PLANS. ADDITIONAL FITTINGS WILL BE REQUIRED FOR VERTICAL DEFLECTIONS NEAR CONNECTION TO EXISTING PIPES, AND AT OTHER LOCATIONS REQUIRING GRADE CHANGES TO AVOID CONFLICTS.
14. THE CONTRACTOR SHALL NOT STORE MATERIALS OR EQUIPMENT OR OPERATE EQUIPMENT WITH ITS TRACKS OR WHEELS PLACED ON PRIVATE PROPERTY WITHOUT WRITTEN APPROVAL OF THE PROPERTY OWNER.
15. THE CONTRACTOR SHALL NOTIFY CBJ WATER UTILITIES OPERATOR LONI VANKIRK (723-4975) OF PROPOSED WATER SERVICE INTERRUPTIONS AND SUBMIT THE "WATER SYSTEM SPECIAL USE PERMIT" (COSIGNED BY THE ENGINEER) AT LEAST 48-HOURS PRIOR TO SHUTDOWN OR FLUSHING OF MAINLINE WATER PIPE. NO WATER SERVICE INTERRUPTION MAY PROCEED UNTIL THIS APPROVAL IS OBTAINED.
16. CONTRACTOR SHALL REFERENCE ALL EXISTING PROPERTY CORNER MONUMENTS (I.E. BRASS CAP MONUMENTS, REBARS OR CHISELED X'S) PRIOR TO CONSTRUCTION THAT WILL BE DISTURBED DURING HIS WORK, AND REMONUMENT AFTER CONSTRUCTION OPERATIONS. ALL WORK SHALL BE DONE BY, OR UNDER THE DIRECTION OF, AN ALASKA REGISTERED LAND SURVEYOR. ALL EXISTING PROPERTY CORNERS ARE NOT NECESSARILY SHOWN ON THE PLANS.
17. THE PLAN DRAWINGS DO NOT NECESSARILY SHOW ALL TREES AND SHRUBS THAT MAY BE ENCOUNTERED DURING CONSTRUCTION ACTIVITIES. NO TREES, SHRUBS OR LANDSCAPING ARE TO BE REMOVED OR DAMAGED, UNLESS SHOWN ON THE DRAWINGS OR DIRECTED BY THE ENGINEER.
18. AEL&P, ACS AND GCI MAY CONDUCT WORK WITHIN THE PROJECT LIMITS TO RELOCATE UTILITIES AND TO UPGRADE THEIR RESPECTIVE SYSTEMS. THE CONTRACTOR SHALL COORDINATE ITS ACTIVITIES WITH EACH UTILITY COMPANY AND PROVIDE ACCESS AS NECESSARY FOR UTILITY COMPANIES TO COMPLETE THEIR WORK.
19. "JUMPING JACK", OR SIMILAR TYPE COMPACTORS SHALL BE USED FOR COMPACTION WITHIN 18-INCHES OF ALL WATER VALVE BOXES, CATCH BASINS AND MANHOLES.
20. THE USE OF GROUT AND QUICKSET CEMENT PRODUCTS WITH ADJUSTING RINGS, BRICKS, WOOD, STONES AND OTHER SIMILAR GRADE ADJUSTMENT DEVICES TO SUPPORT CATCH BASIN FRAMES OVER CATCH BASINS AND MANHOLES WILL NOT BE PERMITTED ON THIS PROJECT. SEE CBJ STANDARD SPECIFICATIONS, SECTION 02502 - STORM SEWER MANHOLES, INLETS AND CATCH BASINS AND THE DRAWINGS FOR CATCH BASIN FRAME SUPPORT REQUIREMENTS. SANITARY SEWER MANHOLES SHALL BE ADJUSTED PER CBJ STANDARD SPECIFICATIONS 02402 - SANITARY SEWER MANHOLES AND CLEANOUTS.
21. THE CONTRACTOR SHALL INSTALL AND MAINTAIN EROSION CONTROL DEVICES AS SPECIFIED IN THE CONTRACTOR'S SWPPP AND ESCP DURING CONSTRUCTION PER SECTION 01570 REQUIREMENTS.
22. TEMPORARY DRIVEWAY RAMPS SHALL BE PROVIDED FOR EACH RESIDENT AS REQUIRED FOR UNRESTRICTED VEHICLE AND BOAT TRAILER ACCESS TO THEIR DRIVEWAYS DURING THE CONSTRUCTION PERIOD.
23. CONTRACTOR SHALL VERIFY LOCATION AND DEPTH OF EXISTING WATER AND SEWER PIPES, INCLUDING ALL SERVICES ALONG THE STORM DRAIN AND WATER PIPE ALIGNMENTS TO DETERMINE PIPE INSULATION LOCATIONS AND TO ENSURE DAMAGE DOES NOT OCCUR TO THE SERVICE PIPES.
24. WATER PIPES WILL REQUIRE MORE THAN 60-INCHES OF COVER IN AREAS WHERE STORM DRAINAGE PIPES ARE CLOSE TO OR BELOW A DEPTH OF 60-INCHES TO INVERT. DEPTHS OF ALL STORM DRAINAGE PIPES SHALL BE DETERMINED PRIOR TO INSTALLING WATER PIPES TO ENSURE CONFLICTS BETWEEN THESE PIPES DO NOT OCCUR. A MINIMUM CLEARANCE OF 8-INCHES SHALL BE OBTAINED BETWEEN WATER AND OTHER PIPES.
25. THE CONTRACTOR SHALL NOTIFY EACH RESIDENT OF EACH DRIVEWAY CLOSURE THE DAY PRECEDING THE CLOSURE. THE RESIDENT SHALL BE INFORMED OF THE PERIOD OF TIME THE CLOSURE WILL BE IN EFFECT. NO DRIVEWAY CLOSURES WILL BE PERMITTED UNTIL THIS REQUIREMENT HAS BEEN MET TO THE SATISFACTION OF THE ENGINEER.
26. THE CONTRACTOR SHALL COORDINATE WITH FIRST STUDENT INC. AND GLACIER VALLEY ELEMENTARY SCHOOL AS NECESSARY TO ENSURE SAFE, UNINTERRUPTED ACCESS FOR SCHOOL BUSES AND STUDENTS WHEN SCHOOL IS IN SESSION.

## ABBREVIATIONS

AC ACS AEL&P APPROX BC BLVD BOP CB CBJ CHB CHL C/L CI CLR CMP CONC CONT CPP CTE DEPT DI DIP DIA E (E) EG EJW EL EOP EP EXIST EXP FG FH FL GCI GV HDPE HP IE L LP LT MAX MIN MJ MTE N N/A NF NFS NTS OC OFCO PC PCC PERF PI P/L POC POL PP PRC PT PVC R ROW RP RT SDMH SS SSCO SSMH STA STD SWPPP	ASBESTOS CEMENT ALASKA COMMUNICATIONS SYSTEMS ALASKA ELECTRIC LIGHT & POWER APPROXIMATE BACK OF CURB BOULEVARD BEGINNING OF PROJECT CATCH BASIN CITY & BOROUGH OF JUNEAU CHORD BEARING CHORD LENGTH CENTERLINE CAST IRON CLEAR CORRUGATED METAL PIPE CONCRETE CONTINUOUS CORRUGATED POLYETHYLENE PIPE CONNECT TO EXISTING DEPARTMENT DUCTILE IRON DUCTILE IRON PIPE DIAMETER EASTING EXISTING EXISTING GRADE EAST JORDAN IRON WORKS ELEVATION END OF PROJECT EDGE OF PAVEMENT EXISTING EXPANSION FINISH GRADE FIRE HYDRANT FLOW LINE GENERAL COMMUNICATION INC. GATE VALVE HIGH DENSITY POLYETHYLENE HIGH PRESSURE INVERT ELEVATION LENGTH LOW POINT LEFT MAXIMUM MINIMUM MECHANICAL JOINT MATCH TO EXISTING NORTHING NOT APPLICABLE NEENAH FOUNDRY COMPANY NON-FROST SUSCEPTIBLE NOT TO SCALE ON CENTER OLYMPIC FOUNDRY CO. POINT OF CURVATURE POINT OF COMPOUND CURVATURE PERFORATED POINT OF INTERSECTION PROPERTY LINE POINT ON CURVE POINT ON LINE POWER POLE POINT OF REVERSE CURVATURE POINT OF TANGENCY POLYVINYL CHLORIDE RADIUS RIGHT-OF-WAY RADIUS POINT RIGHT STORM DRAIN MANHOLE SANITARY SEWER SANITARY SEWER CLEANOUT SANITARY SEWER MANHOLE STATION STANDARD STORM WATER POLLUTION PREVENTION PLAN	T TANGENT TOP BACK OF GUTTER TEMPORARY BENCH MARK TOP OF CONCRETE TOP OF BANK TOP OF PIPE TYPICAL UNDERDRAIN UNLESS OTHERWISE NOTED UNDERGROUND STORAGE TANK VERTICAL CURVE VERTICAL VERTICAL POINT OF INTERSECTION WITH  TBG TBM TC TOB TOP TYP UD UON  UST  VC VERT VPI  W/
---	---	---

## SYMBOLS

EXISTING	REMOVE	PROPOSED	
— — — — —	— — — — —	— — — — —	PROPERTY / BOUNDARY LINE
- - - - -	- - - - -	- - - - -	EASEMENT LINE
— — — — —	— — — — —	— — — — —	PROJECT BASELINE
			SANITARY SEWER MANHOLE
			SANITARY SEWER LINE
			SANITARY SEWER SERVICE CLEANOUT
			STORM DRAIN PIPE
			STORM DRAIN CATCH BASIN
			STORM DRAIN MANHOLE
— — — — —	— — — — —	— — — — —	CURB & GUTTER, TYPE I
— — — — —	— — — — —	— — — — —	VALLEY GUTTER, TYPE III
			ASPHALT SURFACE
			CONCRETE SURFACE
— — — — —	— — — — —	— — — — —	SAWCUT AND MTE
— — — — —	— — — — —	— — — — —	WATER LINE
			WATER VALVE/CURB STOP
			FIRE HYDRANT
			PROTECTION BOLLARDS
— — — — —	— — — — —	— — — — —	UTILITY POLE ANCHOR WIRE
— — — — —	— — — — —	— — — — —	OVERHEAD UTILITIES
— — — — —	— — — — —	— — — — —	UNDERGROUND ELECTRICAL
— — — — —	— — — — —	— — — — —	UNDERGROUND CABLE
— — — — —	— — — — —	— — — — —	UNDERGROUND TELEPHONE
— — — — —	— — — — —	— — — — —	TOP OF BANK
— — — — —	— — — — —	— — — — —	TOE OF SLOPE
— — — — —	— — — — —	— — — — —	DITCH / SWALE
			SIGN
			MAILBOX (SINGLE)
			MAILBOX (GANG)
— — — — —	— — — — —	— — — — —	WOOD FENCE
— — — — —	— — — — —	— — — — —	CHAIN LINK FENCE
			MISCELLANEOUS LANDSCAPING
			DECIDUOUS TREE
			CONIFER TREE
			STRUCTURE
			LIGHT POLE
			UTILITY POLE

P:\2022\2022JN-CBJ\_Tongass\CC001\01\202222JN.dwg PLOT: April 07, 2023 10:46:46am

DESIGN	KAP
DRAWN	JMK
CHECK	JMP
APPROVED	JMP
FILE:	

No.	DATE	REVISION

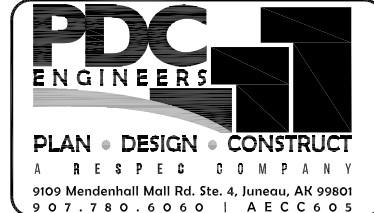

TONGASS BOULEVARD  
RECONSTRUCTION  
PHASE I

CBJ CONTRACT No. BE21-150  
CITY & BOROUGH OF JUNEAU, ALASKA

GENERAL NOTES,  
ABBREVIATIONS AND  
SYMBOLS

DATE: Apr 07, 2023	PDC No. 20232JN
SHEET	
C002	









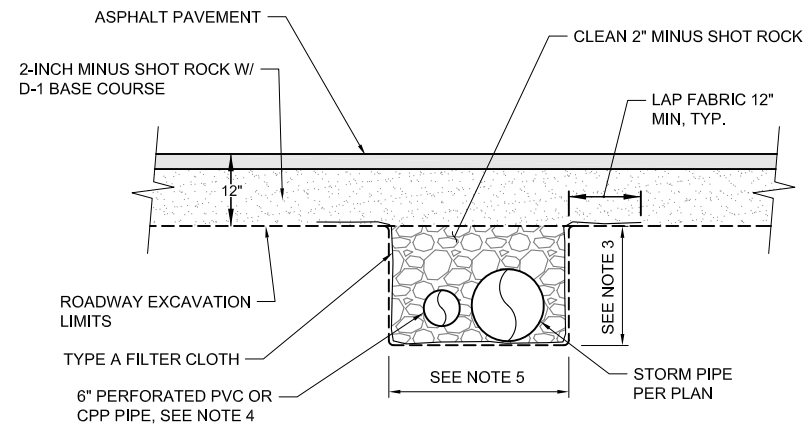

- NOTES:**
1. OUTFALL CONNECTIONS WILL BE INTO CATCH BASINS.
  2. BOTH ENDS OF PIPES SHALL BE CONNECTED IN STORM DRAIN STRUCTURES AND THE FILTER CLOTH FOLDED AND OVERLAPPED TO SEAL END OF DRAINAGE ROCK SECTION.
  3. DEPTH VARIES, SEE PLAN VIEWS.
  4. MINIMUM PIPE SLOPE SHALL BE 1%.
  5. MINIMUM TRENCH WIDTH:  
 18" WHEN NO STORM DRAIN IS PRESENT  
 30" WHEN 12" STORM DRAIN IS PRESENT  
 38" WHEN 18" STORM DRAIN IS PRESENT  
 42" WHEN 24" STORM DRAIN IS PRESENT

**1 6" UNDERDRAIN DETAIL**  
 C101 SCALE: NTS

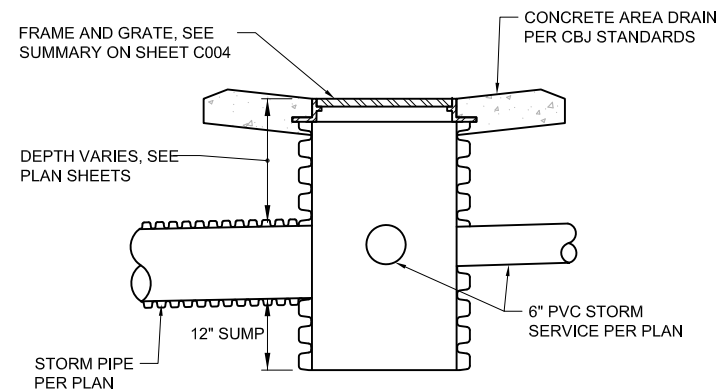

- NOTES:**
1. SEE PLAN SHEETS FOR NUMBER AND ORIENTATION OF PIPES.
  2. THE 24-INCH CPP INLET SHALL HAVE A FACTORY SEALED BOTTOM PLATE.
  3. THE INLET AND OUTLET PIPES SHALL BE FACTORY SEALED.
  4. FIELD INLET FINAL ELEVATIONS TO BE DETERMINED BY ENGINEER PRIOR TO FINAL PLACEMENT OF FRAME, GRATE AND AREA DRAIN. PLAN ELEVATIONS ARE APPROXIMATE AND SUBJECT TO ADJUSTMENT BY ENGINEER AFTER FINAL GRADING TO ENSURE THAT THE AREA DRAIN DOES NOT CONFLICT WITH SURROUNDING GRADES.

**2 24-INCH CPP INLET DETAIL**  
 C101 SCALE: NTS

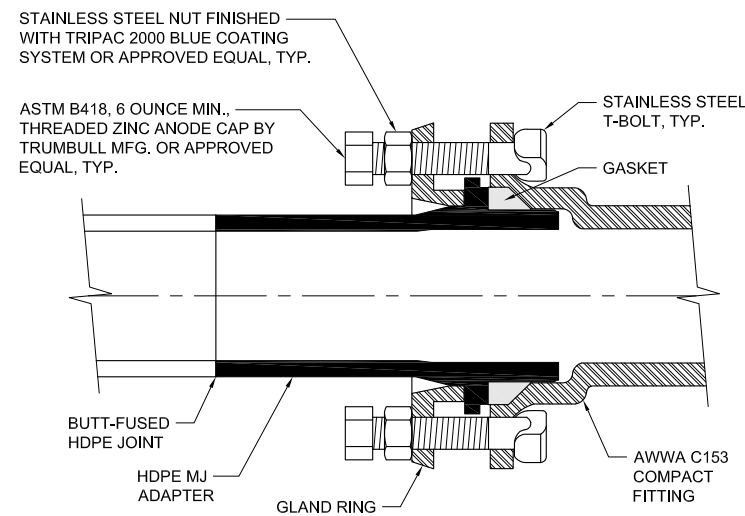

**3 TYPICAL HDPE MJ CONNECTION TO DI FITTING**  
 C101 SCALE: NTS

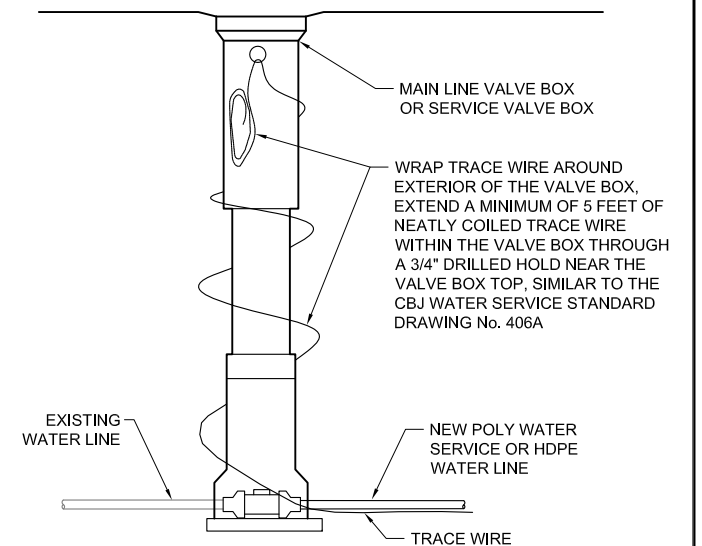

**4 MAIN LINE VALVE & SERVICE VALVE TRACE WIRE TERMINATION DETAIL**  
 C101 SCALE: NTS

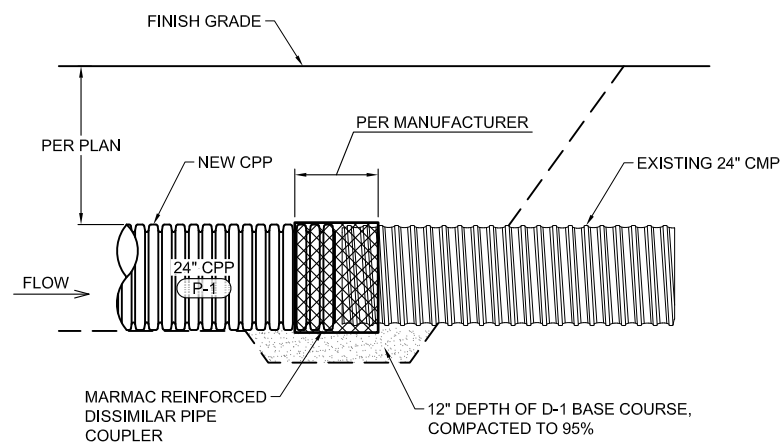

**5 DISSIMILAR STORM PIPE CONNECTION DETAIL**  
 C101 SCALE: NTS

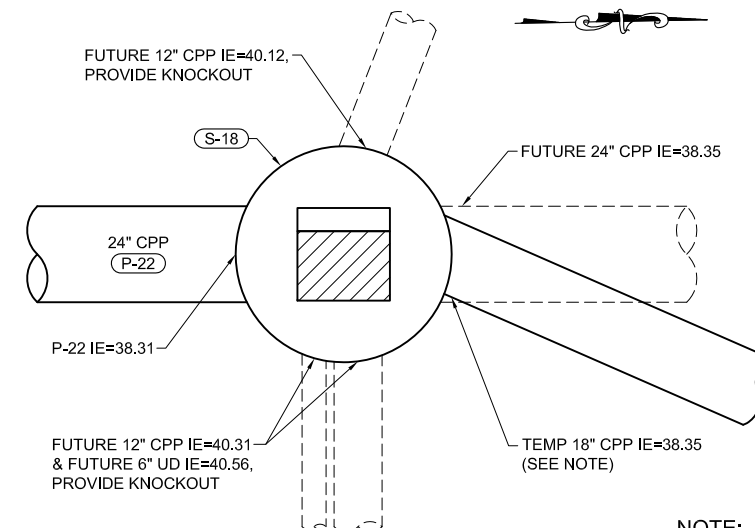

**NOTE:**  
 18" CPP WILL BE REMOVED IN FUTURE PHASE. SIZE BLOCK-OUT FOR FUTURE 24" CPP.

**6 STORM DRAIN MANHOLE S-18 DETAIL**  
 C101 SCALE: NTS

P:\2020\2022\22-JUN-CEU\_Tongass\CC3001.dwg PLOT: April 07, 2021 utt-456pm

DESIGN	KAP
DRAWN	JMK
CHECK	JMP
APPROVED	JMP
FILE:	

No.	DATE	REVISION

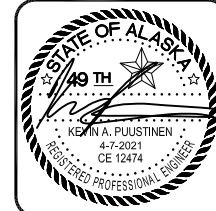
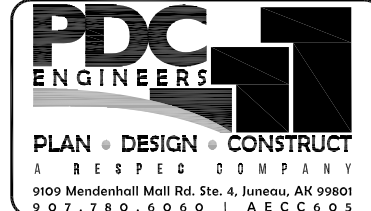

**TONGASS BOULEVARD RECONSTRUCTION PHASE I**  
 CBJ CONTRACT No. BE21-150  
 CITY & BOROUGH OF JUNEAU, ALASKA

**CONSTRUCTION DETAILS**  
 SHEET  
**C101**

DATE:	Apr 07, 2021
PDC No.	20232JN
SHEET	C101

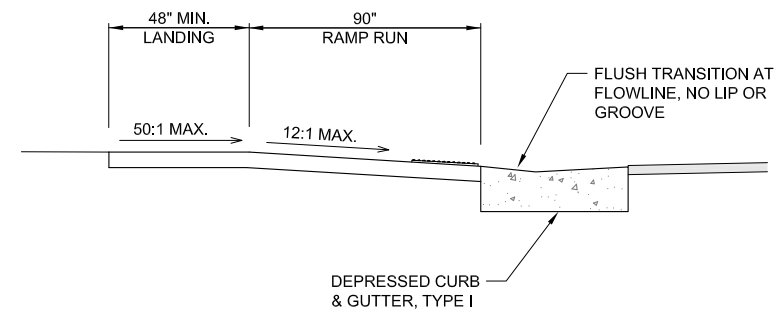
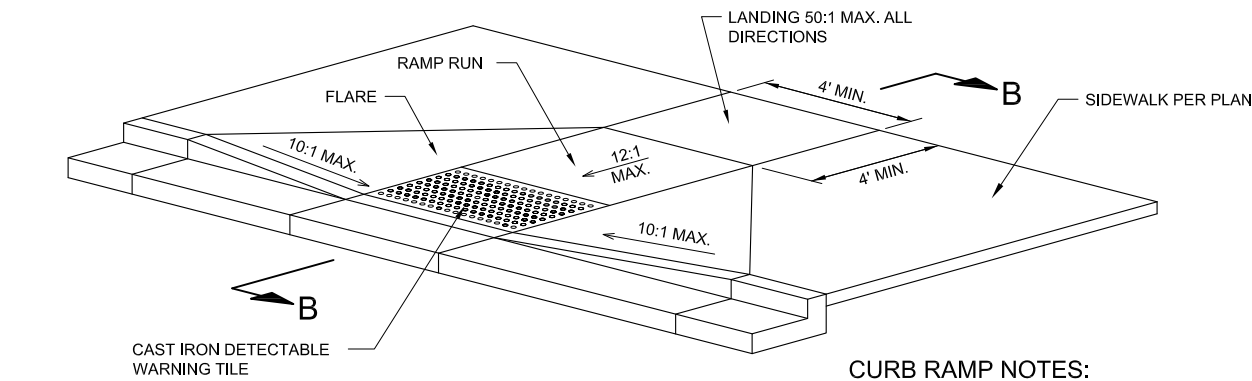

**SECTION B-B**

- CURB RAMP NOTES:**
- RAMP RUNS SHALL BE PERPENDICULAR TO THE FACE OF CURB.
  - CONSTRUCT RAMP RUNS AND FLARES OF CONCRETE, REGARDLESS OF WHETHER THE SIDEWALK IS ASPHALT OR CONCRETE. CONCRETE RAMP RUNS AND FLARES SHALL BE 6" THICK.
  - RAMP RUN AND FLARE LENGTHS SHOWN PERTAIN TO 6" CURB HEIGHTS AND NO LONGITUDINAL SIDEWALK SLOPE. FOR OTHER HEIGHTS AND SLOPES, INCREASE OR DECREASE RUN AND FLARE LENGTHS TO MAINTAIN THE SLOPES SHOWN.
  - WHERE SIDEWALK SLOPE MAKES IT NECESSARY TO LENGTHEN A RAMP RUN TO AVOID EXCEEDING THE ALLOWABLE SLOPE, IT SHOULD NOT BE MADE LONGER THAN 15 FEET FOR A 6" CURB HEIGHT OR, IN GENERAL, 30 TIMES THE CURB HEIGHT. SIMILARLY A FLARE SHOULD NOT BE MADE LONGER THAN 6 FEET FOR A 6" CURB HEIGHT OR, IN GENERAL, 12 TIMES THE CURB HEIGHT. THE SLOPES RESULTING FROM THOSE RUN OR FLARE LENGTHS ARE ACCEPTABLE, EVEN IF THEY EXCEED THE MAXIMUM SLOPES SHOWN.
  - THE 10:1, 12:1 AND 50:1 SLOPES SHOWN ARE THE STEEPEST SLOPES ALLOWED BY LAW (EXCEPT AS PROVIDED UNDER NOTE 4).
  - PROVIDE A COARSE BROOM FINISH RUNNING PARALLEL TO THE CURB ON RAMP RUNS AND FLARES.

**1 PERPENDICULAR CURB RAMP DETAIL**  
C102 SCALE: NTS

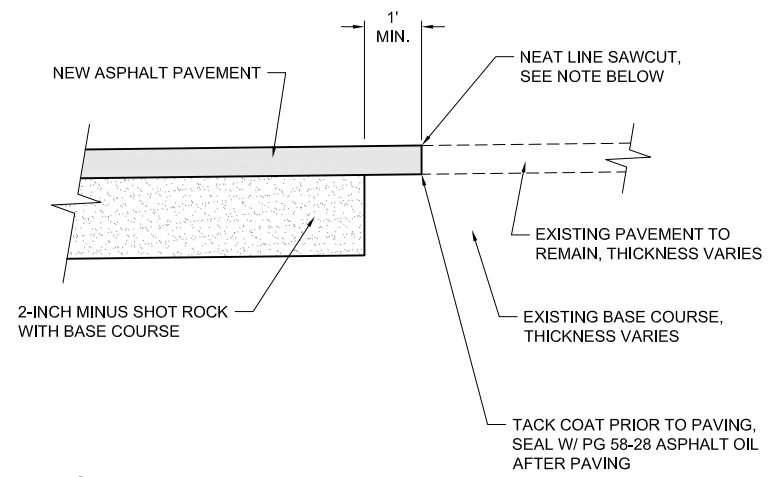

**NOTE:**  
FINAL SAWCUT OF EXISTING PAVEMENT SHALL NOT BE MADE UNTIL 24 HOURS PRIOR TO FINAL PAVING.

**3 PAVEMENT MATCH DETAIL**  
C102 SCALE: NTS

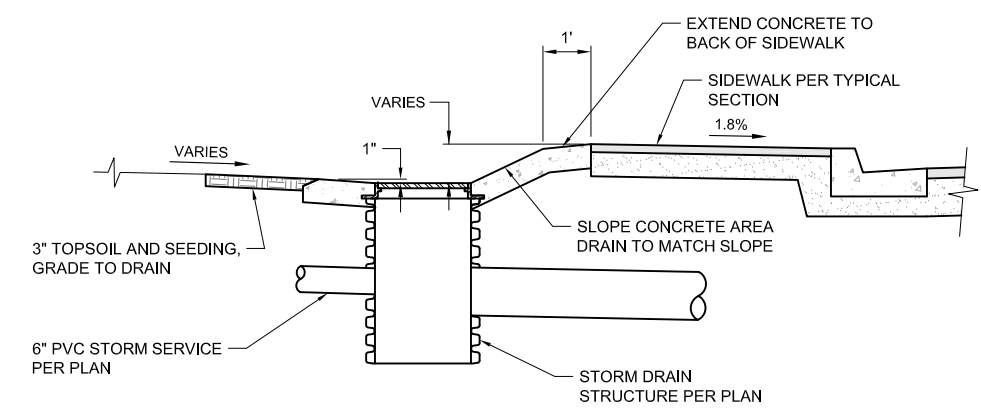

**NOTE:**  
THIS DETAIL APPLIES TO STORM DRAIN STRUCTURES S-3, S-10, S-12 & S-14.

**2 MODIFIED AREA DRAIN BEHIND SIDEWALK DETAIL**  
C102 SCALE: NTS

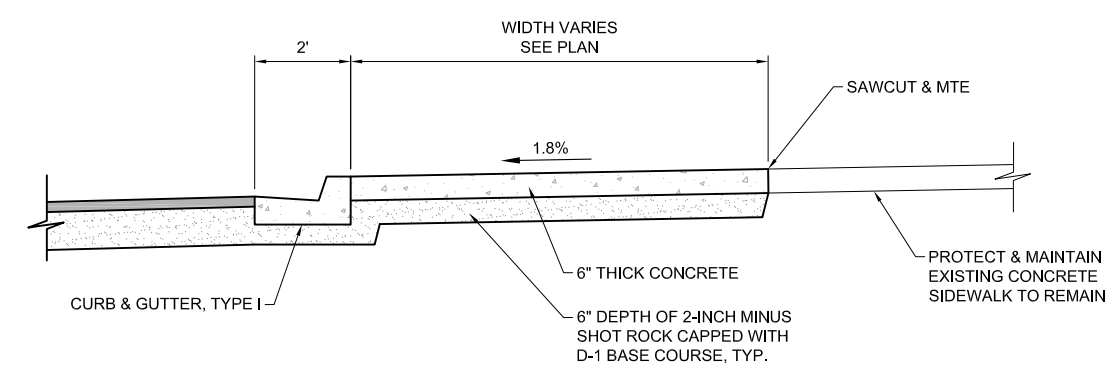

**4 WIDENED CONCRETE SIDEWALK**  
C102 SCALE: NTS

P:\2023\20232232\N-CBJ\_Tongass\CC300\c102\20232232.dwg PLOT: April 07, 2021 10:45:56am

DESIGN	KAP
DRAWN	JMK
CHECK	JMP
APPROVED	JMP
FILE:	

No.	DATE	REVISION

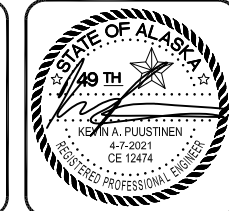
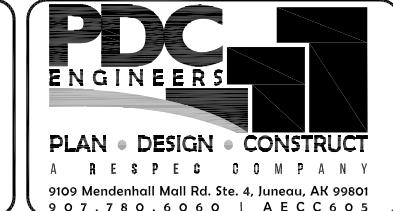

**TONGASS BOULEVARD RECONSTRUCTION PHASE I**  
CBJ CONTRACT No. BE21-150  
CITY & BOROUGH OF JUNEAU, ALASKA

**CONSTRUCTION DETAILS**

DATE:	Apr 07, 2021
PDC No.	20232JIN
SHEET	C102



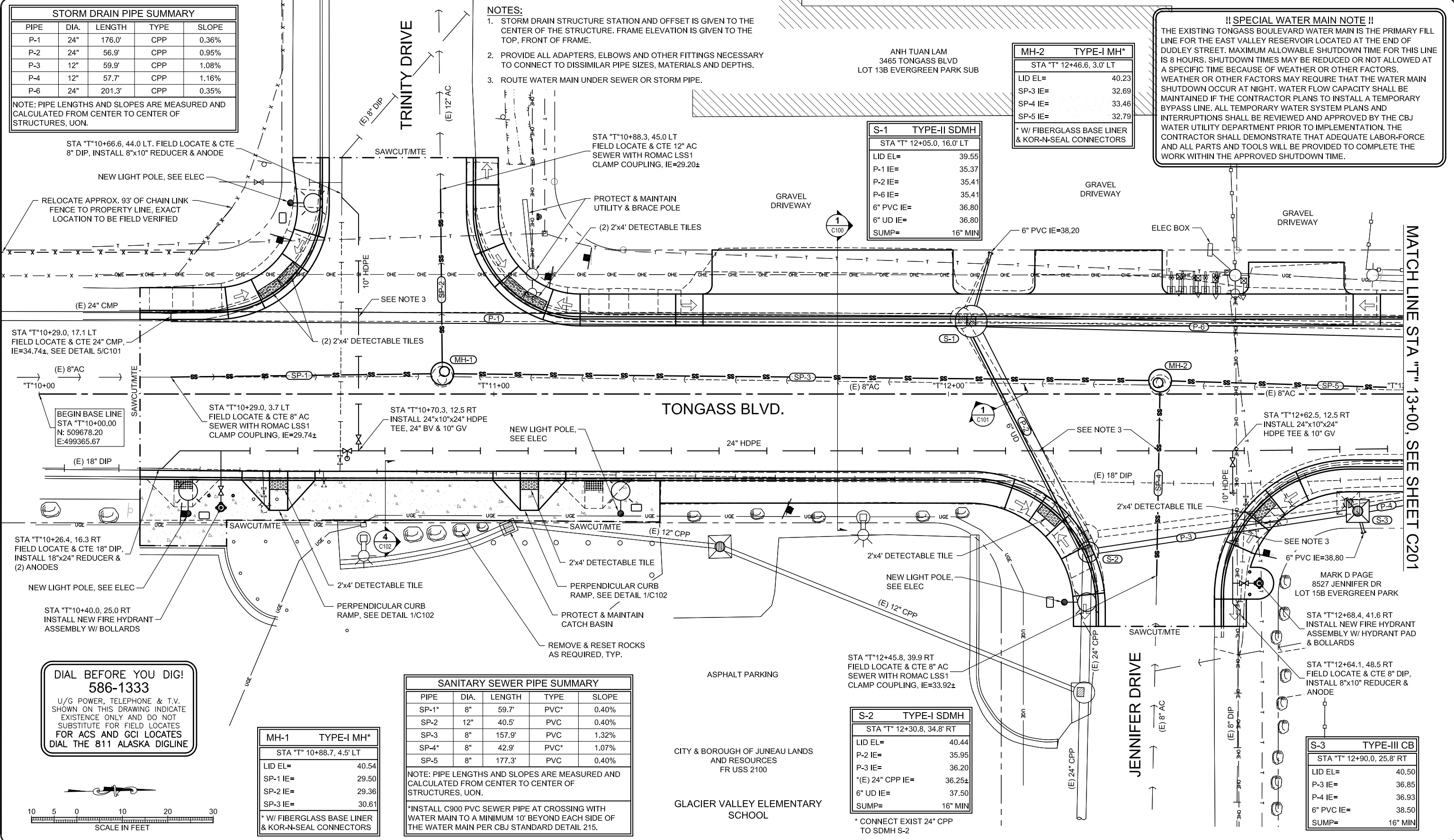

**STORM DRAIN PIPE SUMMARY**

PIPE	DIA.	LENGTH	TYPE	SLOPE
P-1	24"	176.0'	CPP	0.36%
P-2	24"	56.9'	CPP	0.95%
P-3	12"	59.9'	CPP	1.08%
P-4	12"	57.7'	CPP	1.16%
P-6	24"	201.3'	CPP	0.35%

NOTE: PIPE LENGTHS AND SLOPES ARE MEASURED AND CALCULATED FROM CENTER TO CENTER OF STRUCTURES, UON.

- NOTES:**
- STORM DRAIN STRUCTURE STATION AND OFFSET IS GIVEN TO THE CENTER OF THE STRUCTURE. FRAME ELEVATION IS GIVEN TO THE TOP, FRONT OF FRAME.
  - PROVIDE ALL ADAPTERS, ELBOWS AND OTHER FITTINGS NECESSARY TO CONNECT TO DISSIMILAR PIPE SIZES, MATERIALS AND DEPTHS.
  - ROUTE WATER MAIN UNDER SEWER OR STORM PIPE.

ANH TUAN LAM  
3465 TONGASS BLVD  
LOT 13B EVERGREEN PARK SUB

**MH-2 TYPE-I MH\***

STA "T" 12+46.6, 3.0' LT	
LID EL=	40.23
SP-3 IE=	32.69
SP-4 IE=	33.46
SP-5 IE=	32.79

\* W/ FIBERGLASS BASE LINER & KOR-N-SEAL CONNECTORS

**S-1 TYPE-II SDMH**

STA "T" 12+05.0, 16.0' LT	
LID EL=	39.55
P-1 IE=	35.37
P-2 IE=	35.41
P-6 IE=	35.41
6" PVC IE=	36.80
6" UD IE=	36.80
SUMP=	16" MIN

**!! SPECIAL WATER MAIN NOTE !!**

THE EXISTING TONGASS BOULEVARD WATER MAIN IS THE PRIMARY FILL LINE FOR THE EAST VALLEY RESERVOIR LOCATED AT THE END OF DUDLEY STREET. MAXIMUM ALLOWABLE SHUTDOWN TIME FOR THIS LINE IS 8 HOURS. SHUTDOWN TIMES MAY BE REDUCED OR NOT ALLOWED AT A SPECIFIC TIME DUE TO WEATHER OR OTHER FACTORS. WEATHER OR OTHER FACTORS MAY REQUIRE THAT THE WATER MAIN SHUTDOWN OCCUR AT NIGHT. WATER FLOW CAPACITY SHALL BE MAINTAINED IF THE CONTRACTOR PLANS TO INSTALL A TEMPORARY BYPASS LINE. ALL TEMPORARY WATER SYSTEM PLANS AND INTERRUPTIONS SHALL BE REVIEWED AND APPROVED BY THE CBJ WATER UTILITY DEPARTMENT PRIOR TO IMPLEMENTATION. THE CONTRACTOR SHALL DEMONSTRATE THAT ADEQUATE LABOR-FORCE AND ALL PARTS AND TOOLS WILL BE PROVIDED TO COMPLETE THE WORK WITHIN THE APPROVED SHUTDOWN TIME.

**SANITARY SEWER PIPE SUMMARY**

PIPE	DIA.	LENGTH	TYPE	SLOPE
SP-1*	8"	59.7'	PVC*	0.40%
SP-2	12"	40.5'	PVC	0.40%
SP-3	8"	157.9'	PVC	1.32%
SP-4*	8"	42.9'	PVC*	1.07%
SP-5	8"	177.3'	PVC	0.40%

NOTE: PIPE LENGTHS AND SLOPES ARE MEASURED AND CALCULATED FROM CENTER TO CENTER OF STRUCTURES, UON.

\*INSTALL C900 PVC SEWER PIPE AT CROSSING WITH WATER MAIN TO A MINIMUM 10' BEYOND EACH SIDE OF THE WATER MAIN PER CBJ STANDARD DETAIL 215.

**MH-1 TYPE-I MH\***

STA "T" 10+88.7, 4.5' LT	
LID EL=	40.54
SP-1 IE=	29.50
SP-2 IE=	29.36
SP-3 IE=	30.61

\* W/ FIBERGLASS BASE LINER & KOR-N-SEAL CONNECTORS

**S-2 TYPE-I SDMH**

STA "T" 12+30.8, 34.8' RT	
LID EL=	40.44
P-2 IE=	35.95
P-3 IE=	36.20
"(E) 24" CPP IE=	36.25±
6" UD IE=	37.50
SUMP=	16" MIN

\* CONNECT EXIST 24" CPP TO SDMH S-2

**S-3 TYPE-III CB**

STA "T" 12+90.0, 25.8' RT	
LID EL=	40.50
P-3 IE=	36.85
P-4 IE=	36.93
6" PVC IE=	38.50
SUMP=	16" MIN

**DIAL BEFORE YOU DIG!**  
**586-1333**

U/G POWER, TELEPHONE & T.V. SHOWN ON THIS DRAWING INDICATE EXISTENCE ONLY AND DO NOT SUBSTITUTE FOR FIELD LOCATES FOR ACS AND GCI LOCATES DIAL THE 811 ALASKA DIGLINE

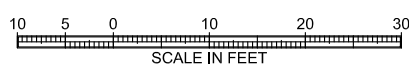

DESIGN: KAP DRAWN: JMK CHECK: JMP APPROVED: JMP FILE:	No. DATE REVISION	<p>CITY AND BOROUGH OF JUNEAU ALASKA'S CAPITAL CITY ENGINEERING &amp; PUBLIC WORKS</p>	<p>PDC ENGINEERS PLAN • DESIGN • CONSTRUCT A RESPEC COMPANY 9109 Mendenhall Mall Rd. Ste. 4, Juneau, AK 99801 907.780.6060   AECC605</p>	<p>STATE OF ALASKA 47-2021 KEVIN A. PUUSTINEN CE 12474 REGISTERED PROFESSIONAL ENGINEER</p>	<p><b>TONGASS BOULEVARD RECONSTRUCTION PHASE I</b></p> <p>CBJ CONTRACT No. BE21-150 CITY &amp; BOROUGH OF JUNEAU, ALASKA</p>	<p><b>PLAN - TONGASS BLVD. TRINITY DRIVE TO STA "T" 13+00</b></p>	DATE: Apr 07, 2021 PDC No. 20232JN SHEET C200
---	-------------------	--	--	---	--	---	---



**NOTES:**

1. STORM DRAIN STRUCTURE STATION AND OFFSET IS GIVEN TO THE CENTER OF THE STRUCTURE. FRAME ELEVATION IS GIVEN TO THE TOP, FRONT OF FRAME.
2. PROVIDE ALL ADAPTERS, ELBOWS AND OTHER FITTINGS NECESSARY TO CONNECT TO DISSIMILAR PIPE SIZES, MATERIALS AND DEPTHS.
3. INSTALL NEW WATER SERVICE, SEE SUMMARY ON SHEET C004.
4. INSTALL NEW SEWER SERVICE, SEE SUMMARY ON SHEET C004.
5. LIMB TREES OVERHANGING SIDEWALK FROM STA "T" 15+00, LT TO STA "T" 18+60, LT TO PROVIDE A MINIMUM 12' CLEARANCE FROM SIDEWALK TO NEAREST LIMB.
6. SEE SPECIAL WATER MAIN NOTE ON SHEET C200.
7. ADJUST EXISTING FRAME & GRATE AS NECESSARY TO ALIGN WITH NEW CURB & GUTTER.
8. ROUTE WATER MAIN ABOVE NEW SEWER SERVICE.
9. ROUTE WATER MAIN UNDER SEWER OR STORM PIPE.

S-6	TYPE-I SDMH
STA "T" 14+04.0, 16.0' LT	
LID EL=	40.79
P-6 IE=	36.11
P-7 IE=	37.14
P-8 IE=	36.15
6" UD IE=	37.60
SUMP=	16" MIN

S-6A	TYPE-III CB
STA "T" 14+04.5, 25.7' LT	
LID EL=	41.55
*(E) 12" CMP IE=	37.32±
P-7 IE=	37.24
6" PVC IE=	39.00
SUMP=	16" MIN

MH-3	TYPE-I MH*
STA "T" 14+23.3, 5.6' LT	
LID EL=	41.29
SP-5 IE=	33.50
SP-6 IE=	33.60

**DIAL BEFORE YOU DIG!**  
**586-1333**  
 U/G POWER, TELEPHONE & T.V. SHOWN ON THIS DRAWING INDICATE EXISTENCE ONLY AND DO NOT SUBSTITUTE FOR FIELD LOCATES FOR ACS AND GCI LOCATES DIAL THE 811 ALASKA DIGLINE

SANITARY SEWER PIPE SUMMARY				
PIPE	DIA.	LENGTH	TYPE	SLOPE
SP-5		SEE SHEET C200		
SP-6*	8"	153.5'	PVC*	0.40%
SP-7	8"	8.0'	PVC	1.00%
SP-8	8"	89.6'	PVC	0.40%

NOTE: PIPE LENGTHS AND SLOPES ARE MEASURED AND CALCULATED FROM CENTER TO CENTER OF STRUCTURES, UON.

\*INSTALL C900 PVC SEWER PIPE AT CROSSING WITH WATER MAIN TO A MINIMUM 10' BEYOND EACH SIDE OF THE WATER MAIN PER CBJ STANDARD DETAIL 215.

MH-4	TYPE-I MH*
STA "T" 15+76.7, 0.3' LT	
LID EL=	42.36
SP-6 IE=	34.21
SP-7 IE=	34.75
SP-8 IE=	34.31

\* W/ FIBERGLASS BASE LINER & KOR-N-SEAL CONNECTORS

S-7	TYPE-I SDMH
STA "T" 15+71.0, 14.5' LT	
LID EL=	41.87
P-8 IE=	36.73
P-9 IE=	36.77
P-10 IE=	36.77
6" PVC IE=	38.77
SUMP=	16" MIN

MATCH LINE STA "T" 13+00, SEE SHEET C200

MATCH LINE STA "T" 16+00, SEE SHEET C202

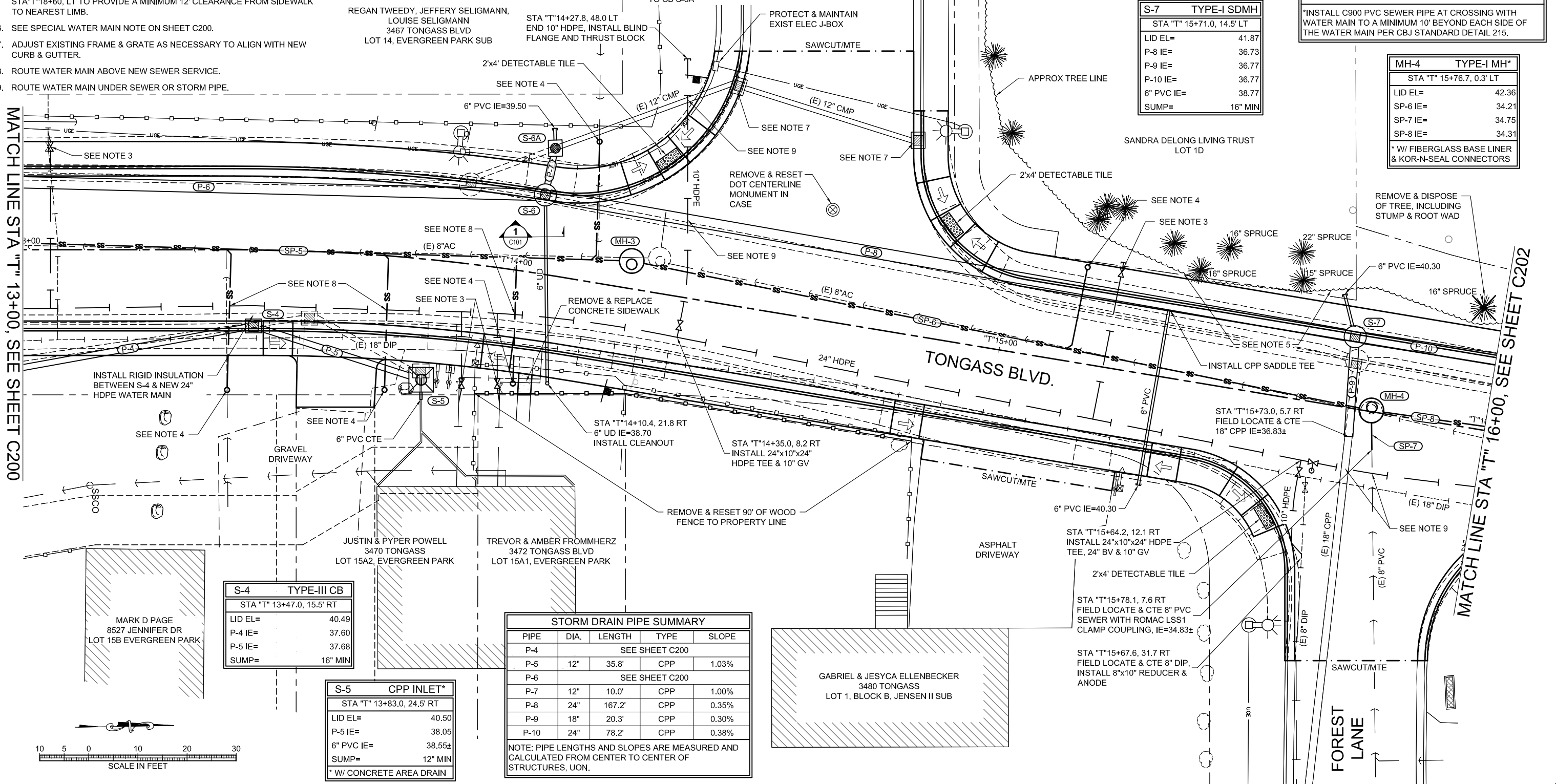

S-4	TYPE-III CB
STA "T" 13+47.0, 15.5' RT	
LID EL=	40.49
P-4 IE=	37.60
P-5 IE=	37.68
SUMP=	16" MIN

STORM DRAIN PIPE SUMMARY				
PIPE	DIA.	LENGTH	TYPE	SLOPE
P-4		SEE SHEET C200		
P-5	12"	35.8'	CPP	1.03%
P-6		SEE SHEET C200		
P-7	12"	10.0'	CPP	1.00%
P-8	24"	167.2'	CPP	0.35%
P-9	18"	20.3'	CPP	0.30%
P-10	24"	78.2'	CPP	0.38%

NOTE: PIPE LENGTHS AND SLOPES ARE MEASURED AND CALCULATED FROM CENTER TO CENTER OF STRUCTURES, UON.

S-5	CPP INLET*
STA "T" 13+83.0, 24.5' RT	
LID EL=	40.50
P-5 IE=	38.05
6" PVC IE=	38.55±
SUMP=	12" MIN

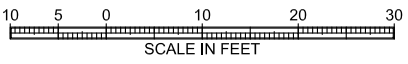

DESIGN	KAP
DRAWN	JMK
CHECK	JMP
APPROVED	JMP
FILE:	

No.	DATE	REVISION

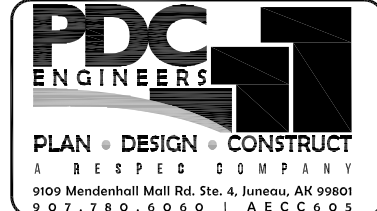

**TONGASS BOULEVARD RECONSTRUCTION PHASE I**  
 CBJ CONTRACT No. BE21-150  
 CITY & BOROUGH OF JUNEAU, ALASKA

**PLAN - TONGASS BLVD.**  
 STA "T" 13+00 TO  
 STA "T" 16+00

DATE:	Apr 07, 2021
PDC No.	20232JN
SHEET	C201





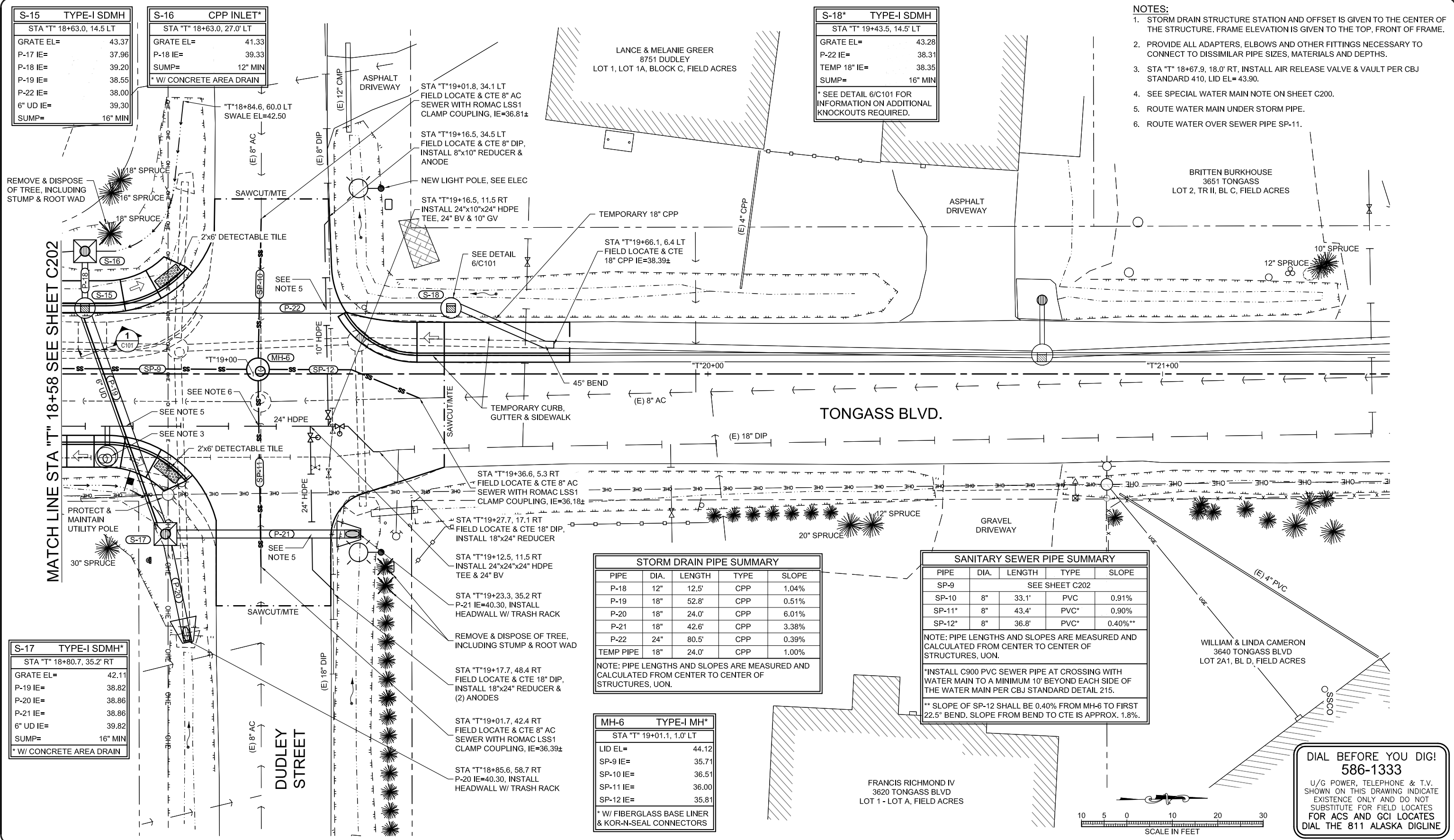

- NOTES:**
1. STORM DRAIN STRUCTURE STATION AND OFFSET IS GIVEN TO THE CENTER OF THE STRUCTURE. FRAME ELEVATION IS GIVEN TO THE TOP, FRONT OF FRAME.
  2. PROVIDE ALL ADAPTERS, ELBOWS AND OTHER FITTINGS NECESSARY TO CONNECT TO DISSIMILAR PIPE SIZES, MATERIALS AND DEPTHS.
  3. STA "T" 18+67.9, 18.0' RT, INSTALL AIR RELEASE VALVE & VAULT PER CBJ STANDARD 410, LID EL= 43.90.
  4. SEE SPECIAL WATER MAIN NOTE ON SHEET C200.
  5. ROUTE WATER MAIN UNDER STORM PIPE.
  6. ROUTE WATER OVER SEWER PIPE SP-11.

**STORM DRAIN PIPE SUMMARY**

PIPE	DIA.	LENGTH	TYPE	SLOPE
P-18	12"	12.5'	CPP	1.04%
P-19	18"	52.8'	CPP	0.51%
P-20	18"	24.0'	CPP	6.01%
P-21	18"	42.6'	CPP	3.38%
P-22	24"	80.5'	CPP	0.39%
TEMP PIPE	18"	24.0'	CPP	1.00%

NOTE: PIPE LENGTHS AND SLOPES ARE MEASURED AND CALCULATED FROM CENTER TO CENTER OF STRUCTURES, UON.

**SANITARY SEWER PIPE SUMMARY**

PIPE	DIA.	LENGTH	TYPE	SLOPE
SP-9	SEE SHEET C202			
SP-10	8"	33.1'	PVC	0.91%
SP-11*	8"	43.4'	PVC*	0.90%
SP-12*	8"	36.8'	PVC*	0.40%**

NOTE: PIPE LENGTHS AND SLOPES ARE MEASURED AND CALCULATED FROM CENTER TO CENTER OF STRUCTURES, UON.

\*INSTALL C900 PVC SEWER PIPE AT CROSSING WITH WATER MAIN TO A MINIMUM 10' BEYOND EACH SIDE OF THE WATER MAIN PER CBJ STANDARD DETAIL 215.

\*\* SLOPE OF SP-12 SHALL BE 0.40% FROM MH-6 TO FIRST 22.5' BEND. SLOPE FROM BEND TO CTE IS APPROX. 1.8%.

**MH-6 TYPE-I MH\***

ITEM	ELEVATION
LID EL=	44.12
SP-9 IE=	35.71
SP-10 IE=	36.51
SP-11 IE=	36.00
SP-12 IE=	35.81

\* W/ FIBERGLASS BASE LINER & KOR-N-SEAL CONNECTORS

**S-15 TYPE-I SDMH**

ITEM	ELEVATION
STA "T" 18+63.0, 14.5 LT	
GRATE EL=	43.37
P-17 IE=	37.96
P-18 IE=	39.20
P-19 IE=	38.55
P-22 IE=	38.00
6" UD IE=	39.30
SUMP=	16" MIN

**S-16 CPP INLET\***

ITEM	ELEVATION
STA "T" 18+63.0, 27.0' LT	
GRATE EL=	41.33
P-18 IE=	39.33
SUMP=	12" MIN

\* W/ CONCRETE AREA DRAIN

**S-18\* TYPE-I SDMH**

ITEM	ELEVATION
STA "T" 19+43.5, 14.5' LT	
GRATE EL=	43.28
P-22 IE=	38.31
TEMP 18" IE=	38.35
SUMP=	16" MIN

\* SEE DETAIL 6/C101 FOR INFORMATION ON ADDITIONAL KNOCKOUTS REQUIRED.

**S-17 TYPE-I SDMH\***

ITEM	ELEVATION
STA "T" 18+80.7, 35.2' RT	
GRATE EL=	42.11
P-19 IE=	38.82
P-20 IE=	38.86
P-21 IE=	38.86
6" UD IE=	39.82
SUMP=	16" MIN

\* W/ CONCRETE AREA DRAIN

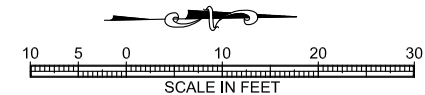

**DIAL BEFORE YOU DIG!**  
**586-1333**  
 U/G POWER, TELEPHONE & T.V. SHOWN ON THIS DRAWING INDICATE EXISTENCE ONLY AND DO NOT SUBSTITUTE FOR FIELD LOCATES FOR ACS AND GCI LOCATES DIAL THE 811 ALASKA DIGLINE

P:\2023\2023232JIN-CBJ\_Tongass\CC2001.dwg PLOT: April 07, 2023, ut: 4:59pm

DESIGN	KAP
DRAWN	JMK
CHECK	JMP
APPROVED	JMP
FILE:	

No.	DATE	REVISION



**TONGASS BOULEVARD RECONSTRUCTION PHASE I**  
 CBJ CONTRACT No. BE21-150  
 CITY & BOROUGH OF JUNEAU, ALASKA

**PLAN - TONGASS BLVD. STA "T" 18+58 TO EOP**

DATE: Apr 07, 2021  
 PDC No. 20232JIN  
 SHEET  
**C203**

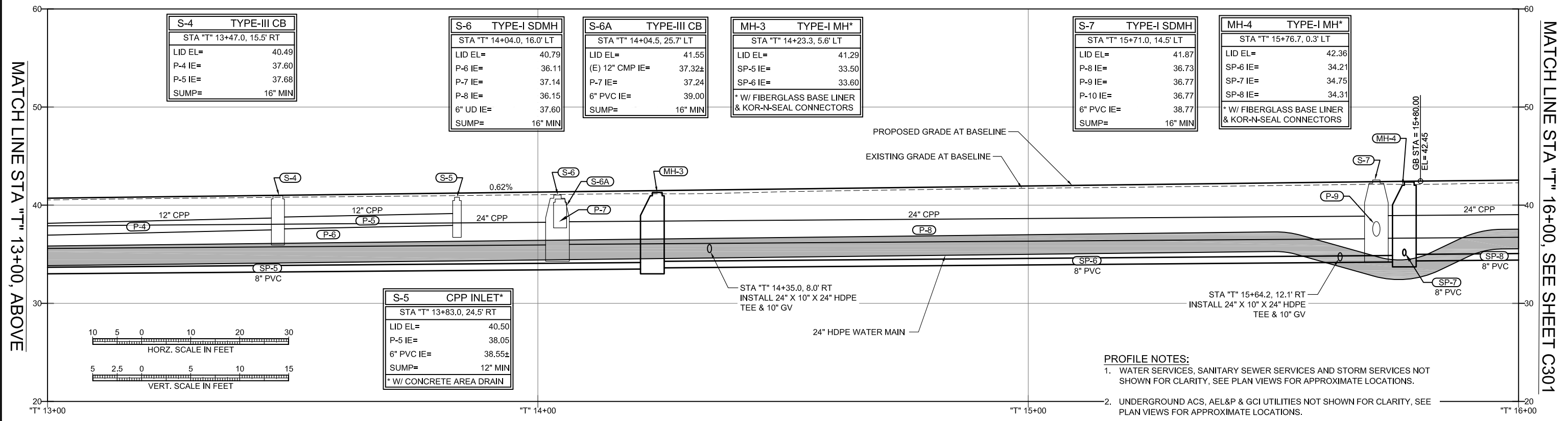
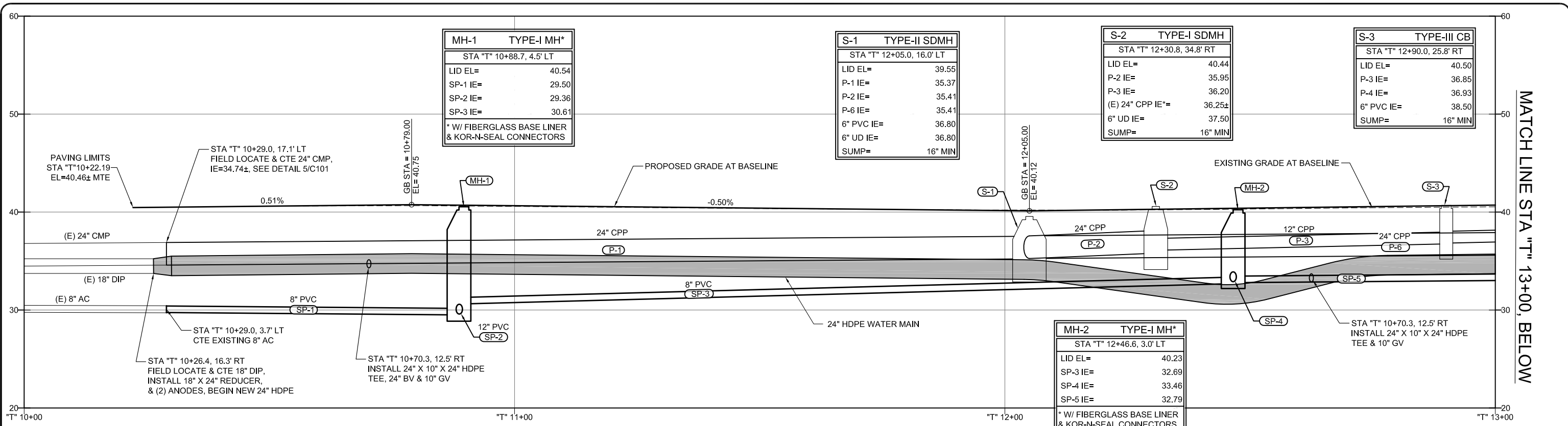

MATCH LINE STA "T" 13+00, ABOVE

MATCH LINE STA "T" 13+00, BELOW

MATCH LINE STA "T" 16+00, SEE SHEET C301

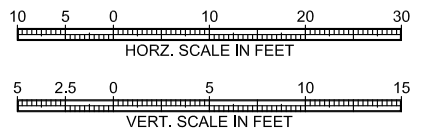

- PROFILE NOTES:**
1. WATER SERVICES, SANITARY SEWER SERVICES AND STORM SERVICES NOT SHOWN FOR CLARITY, SEE PLAN VIEWS FOR APPROXIMATE LOCATIONS.
  2. UNDERGROUND ACS, AEL&P & GCI UTILITIES NOT SHOWN FOR CLARITY, SEE PLAN VIEWS FOR APPROXIMATE LOCATIONS.
  3. 6" PVC STORM AND 6" UNDERDRAINS NOT SHOWN FOR CLARITY.

DESIGN	KAP
DRAWN	JMK
CHECK	JMP
APPROVED	JMP
FILE:	

No.	DATE	REVISION



**TONGASS BOULEVARD RECONSTRUCTION PHASE I**  
 CBJ CONTRACT No. BE21-150  
 CITY & BOROUGH OF JUNEAU, ALASKA

**PROFILE - TONGASS BLVD. TRINITY DRIVE TO STA "T" 16+00**

DATE:	Apr 07, 2021
PDC No.:	20232JN
SHEET:	C300

MATCH LINE STA "T" 16+00, SEE SHEET C300

MATCH LINE STA "T" 18+90, BELOW

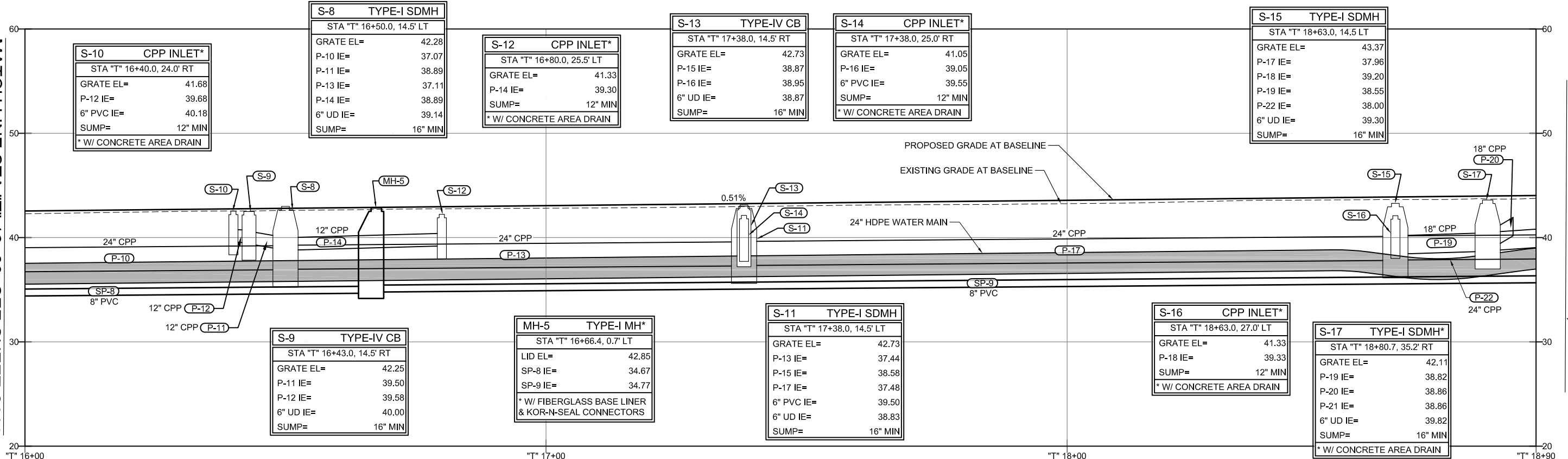

MATCH LINE STA "T" 18+90, ABOVE

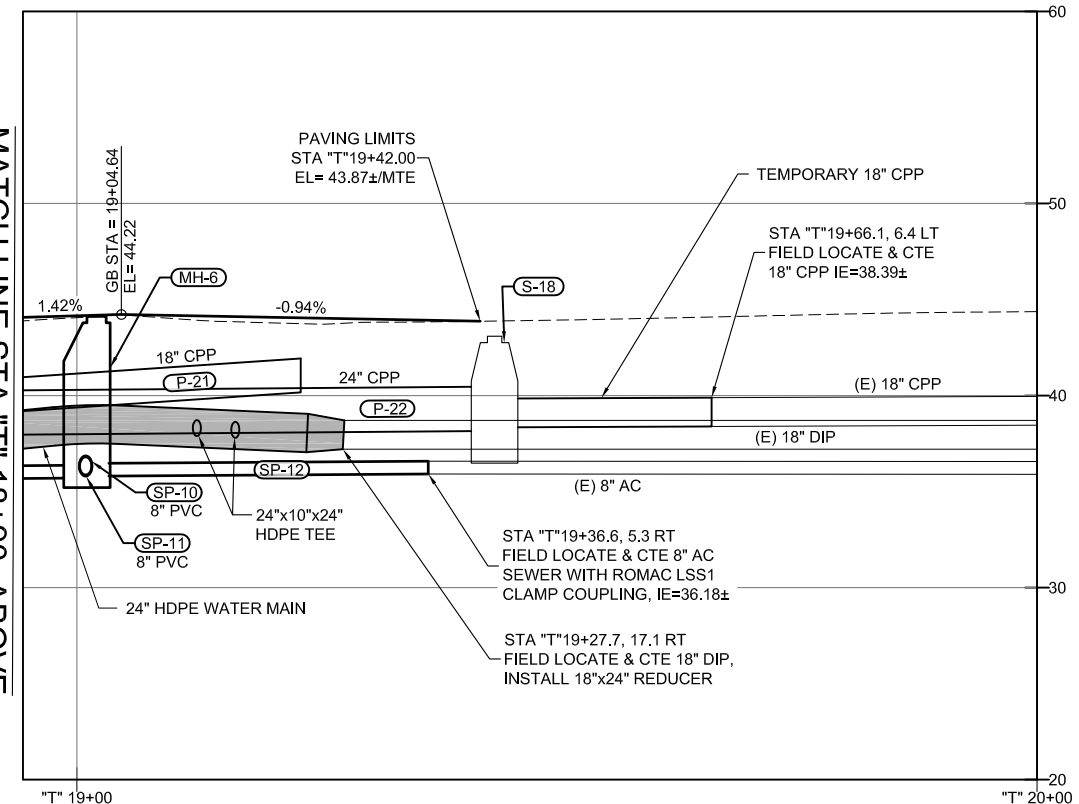

S-18*	TYPE-I SDMH
STA "T" 19+43.5, 14.5' LT	
GRATE EL=	43.28
P-22 IE=	38.31
TEMP 18" IE=	38.35
SUMP=	16" MIN
* SEE DETAIL 6/C101 FOR INFORMATION ON ADDITIONAL KNOCKOUTS REQUIRED.	

MH-6	TYPE-I MH*
STA "T" 19+01.1, 1.0' LT	
LID EL=	44.12
SP-9 IE=	35.71
SP-10 IE=	36.51
SP-11 IE=	36.00
SP-12 IE=	35.81
* W/ FIBERGLASS BASE LINER & KOR-N-SEAL CONNECTORS	

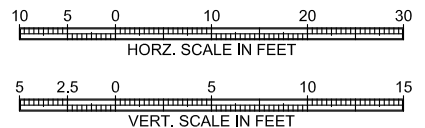

- PROFILE NOTES:**
1. WATER SERVICES, SANITARY SEWER SERVICES AND STORM SERVICES NOT SHOWN FOR CLARITY, SEE PLAN VIEWS FOR APPROXIMATE LOCATIONS.
  2. UNDERGROUND ACS, AEL&P & GCI UTILITIES NOT SHOWN FOR CLARITY, SEE PLAN VIEWS FOR APPROXIMATE LOCATIONS.
  3. 6" PVC STORM AND 6" UNDERDRAINS NOT SHOWN FOR CLARITY.

DESIGN	KAP
DRAWN	JMK
CHECK	JMP
APPROVED	JMP
FILE:	



**TONGASS BOULEVARD RECONSTRUCTION PHASE I**  
 CBJ CONTRACT No. BE21-150  
 CITY & BOROUGH OF JUNEAU, ALASKA

**PROFILE - TONGASS BLVD. STA "T" 16+00 TO EOP**

DATE:	Apr 07, 2021
PDC No.:	20232JN
SHEET	C301



MATCH LINE STA "T" 13+00, SEE SHEET C400

MATCH LINE STA "T" 16+00, SEE SHEET C402

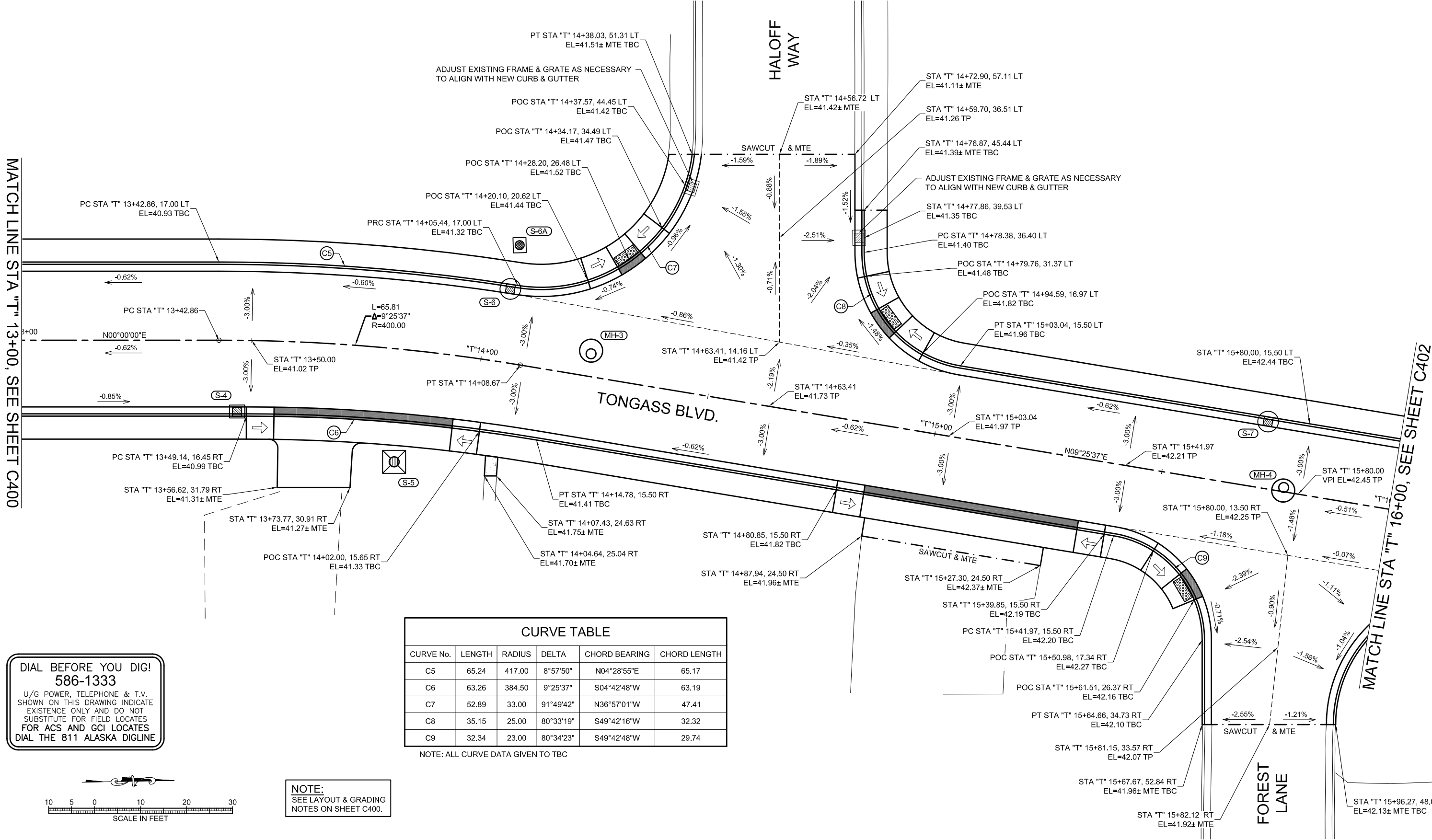

**CURVE TABLE**

CURVE No.	LENGTH	RADIUS	DELTA	CHORD BEARING	CHORD LENGTH
C5	65.24	417.00	8°57'50"	N04°28'55"E	65.17
C6	63.26	384.50	9°25'37"	S04°42'48"W	63.19
C7	52.89	33.00	91°49'42"	N36°57'01"W	47.41
C8	35.15	25.00	80°33'19"	S49°42'16"W	32.32
C9	32.34	23.00	80°34'23"	S49°42'48"W	29.74

NOTE: ALL CURVE DATA GIVEN TO TBC

**DIAL BEFORE YOU DIG!**  
**586-1333**  
 U/G POWER, TELEPHONE & T.V. SHOWN ON THIS DRAWING INDICATE EXISTENCE ONLY AND DO NOT SUBSTITUTE FOR FIELD LOCATES FOR ACS AND GCI LOCATES DIAL THE 811 ALASKA DIGLINE

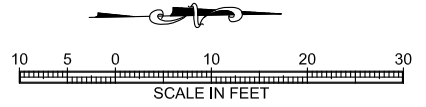

NOTE:  
 SEE LAYOUT & GRADING NOTES ON SHEET C400.

DESIGN	KAP
DRAWN	JMK
CHECK	JMP
APPROVED	JMP
FILE:	

No.	DATE	REVISION



**TONGASS BOULEVARD RECONSTRUCTION PHASE I**  
 CBJ CONTRACT No. BE21-150  
 CITY & BOROUGH OF JUNEAU, ALASKA

**PAVEMENT AND GUTTER LAYOUT - TONGASS BLVD.**  
 STA "T" 13+00 TO STA "T" 16+00

DATE:	Apr 07, 2021
PDC No.	20232JN
SHEET	<b>C401</b>

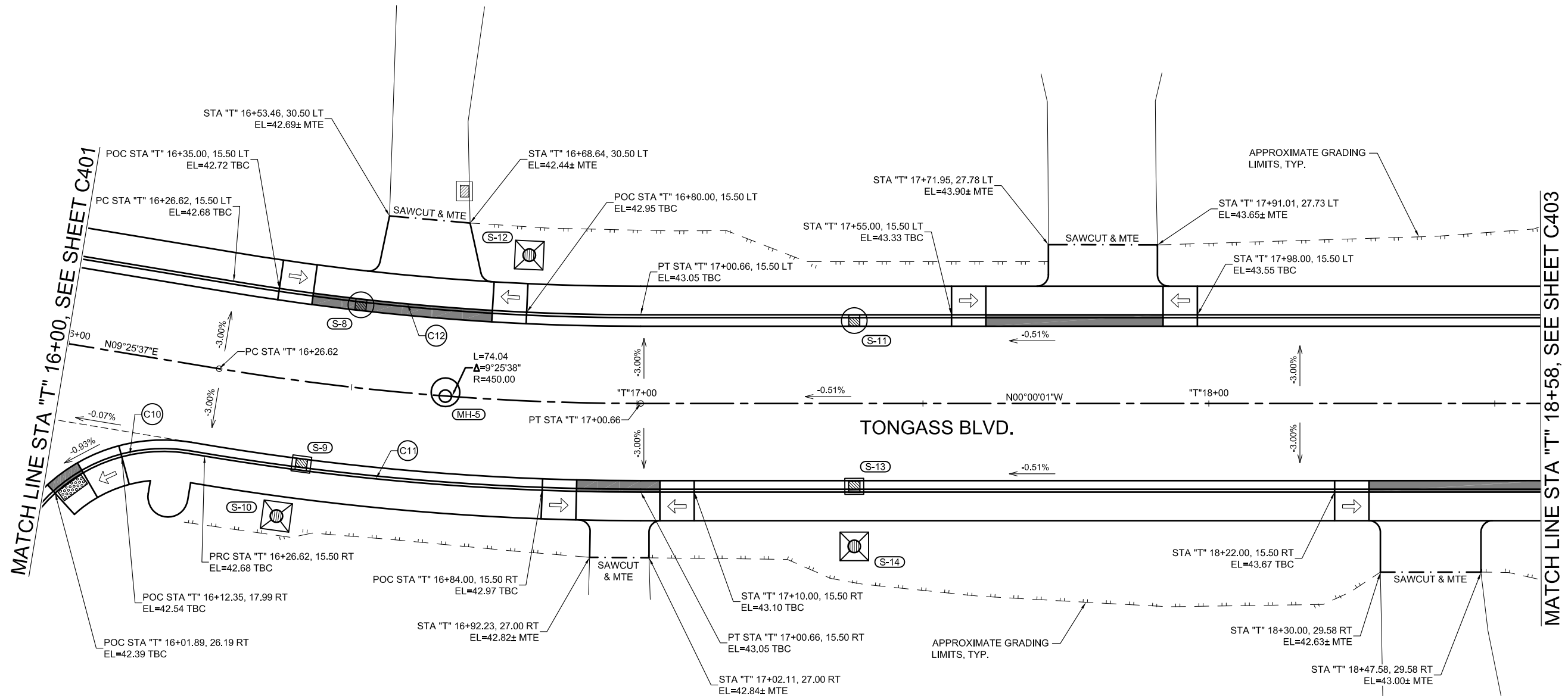

CURVE TABLE					
CURVE No.	LENGTH	RADIUS	DELTA	CHORD BEARING	CHORD LENGTH
C10	48.59	28.00	99°25'37"	S40°17'12"E	42.72
C11	76.59	465.50	9°25'38"	N04°42'48"E	76.51
C12	71.49	434.50	9°25'38"	N04°42'48"E	71.41

NOTE: ALL CURVE DATA GIVEN TO TBC

**DIAL BEFORE YOU DIG!  
586-1333**  
U/G POWER, TELEPHONE & T.V. SHOWN ON THIS DRAWING INDICATE EXISTENCE ONLY AND DO NOT SUBSTITUTE FOR FIELD LOCATES FOR ACS AND GCI LOCATES DIAL THE 811 ALASKA DIGLINE

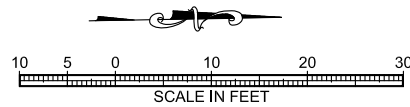

NOTE:  
SEE LAYOUT & GRADING NOTES ON SHEET C400.

P:\2020\2022\22\AK-CBJ\_Tongass\CC200303.dwg PLOT: April 07, 2021 at: 5:50pm

DESIGN	KAP
DRAWN	JMK
CHECK	JMP
APPROVED	JMP
FILE:	

No.	DATE	REVISION

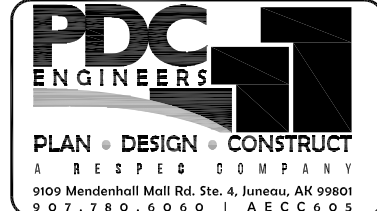

**TONGASS BOULEVARD RECONSTRUCTION PHASE I**  
CBJ CONTRACT No. BE21-150  
CITY & BOROUGH OF JUNEAU, ALASKA

**PAVEMENT AND GUTTER LAYOUT - TONGASS BLVD.**  
STA "T" 16+00 TO STA "T" 18+58

DATE:	Apr 07, 2021
PDC No.	20232JN
SHEET	<b>C402</b>





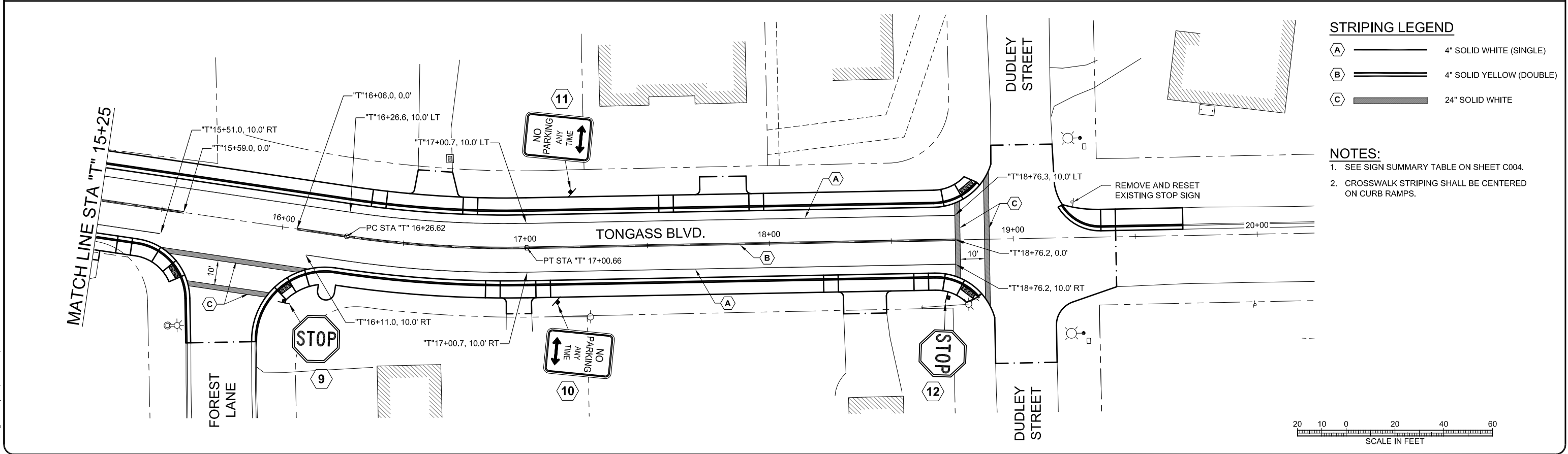
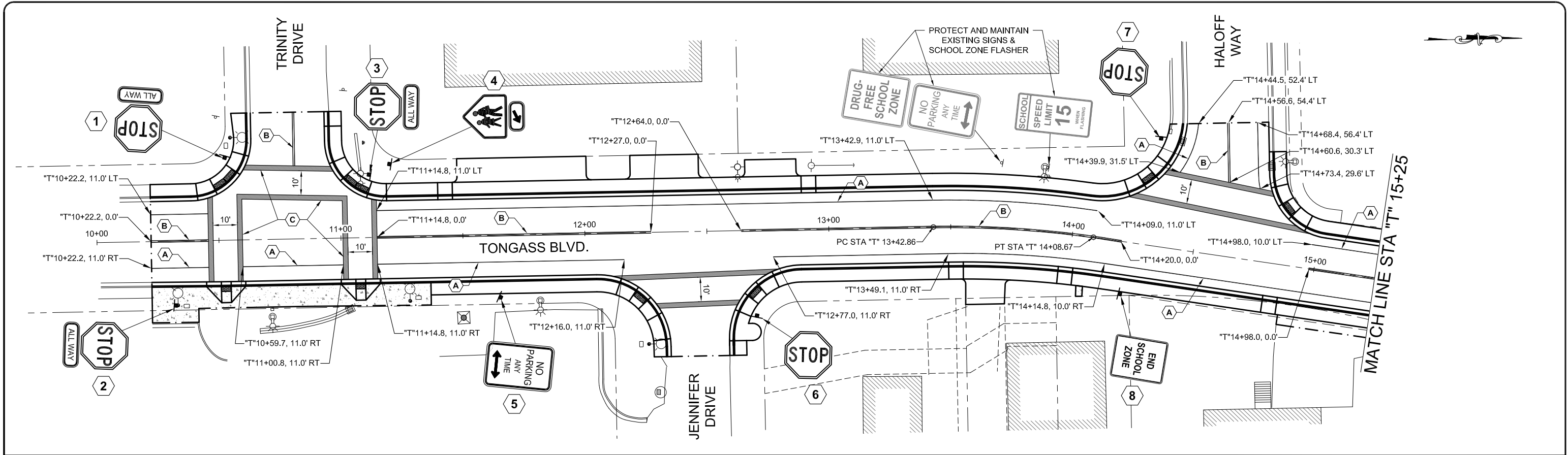

**STRIPING LEGEND**

A	4" SOLID WHITE (SINGLE)
B	4" SOLID YELLOW (DOUBLE)
C	24" SOLID WHITE

- NOTES:**
- SEE SIGN SUMMARY TABLE ON SHEET C004.
  - CROSSWALK STRIPING SHALL BE CENTERED ON CURB RAMPS.

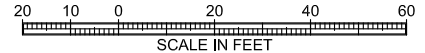

DESIGN	KAP
DRAWN	JMK
CHECK	JMP
APPROVED	JMP
FILE:	

No.	DATE	REVISION



**TONGASS BOULEVARD RECONSTRUCTION PHASE I**  
 CBJ CONTRACT No. BE21-150  
 CITY & BOROUGH OF JUNEAU, ALASKA

**SIGNING & STRIPING PLAN**

DATE:	Apr 07, 2021
PDC No.	20232JN
SHEET	C500



GENERAL NOTES:

- REFER TO THE CIVIL DRAWING C002 FOR GENERAL CIVIL CONSTRUCTION NOTES. REFER TO CIVIL PLAN DRAWINGS C200 THROUGH C203 FOR DETAILED INFORMATION REGARDING OTHER UTILITIES AND FINISHED SURFACES.
- THE PROJECT SHALL COMPLY WITH ALL APPLICABLE CBJ ENGINEERING STANDARDS. STANDARDS ARE AVAILABLE ON THE CBJ ENGINEERING DEPARTMENT WEBSITE. REFER TO STANDARD 118 – STREET LIGHTING, STANDARD 119A – JUNCTION BOX TYPE 1 AND 1A, AND STANDARD 125 – PAVEMENT RESURFACING AND TRENCH DETAIL.
- THE LIGHTING CIRCUITS SHALL BE CONNECTED TO THE UTILITY THROUGH A FUSED DISCONNECT SWITCH. THE CONTRACTOR SHALL PROVIDE ALL MATERIALS REQUIRED FOR THE PROJECT. THE UTILITY POLE RISER CONDUITS AND WEATHERHEADS, AND CONDUCTORS FROM THE SOURCE TO THE FUSED DISCONNECT SWITCH SHALL BE INSTALLED BY THE UTILITY. COORDINATE ALL WORK.
- SPLICE LIGHTING CIRCUITS WITH SEC DOUBLE-FUSED CONNECTOR KIT MODEL 1791-DF, OR SIMILAR.
- TYPE A LIGHT POLE: 30-FOOT, ROUND, TAPERED GALVANIZED STEEL WITH 8-FOOT ARM. VALMONT, OR APPROVED EQUAL.
- TYPE A LUMINAIRE: CREE LIGHTING RSWL B HT 2ME 14L 40K7 UL GY N Q1 SS BLSL, OR APPROVED EQUAL.

LEGEND	
SYMBOL	DESCRIPTION
	POLE MOUNTED LUMINAIRE
	HANDHOLE
	FUSED DISCONNECT SWITCH
	DETAIL REFERENCE
C	CONDUIT
(E)	EXISTING
G	GROUND
P	PHASE
W	WIRE

LIGHT POLE SUMMARY TABLE			
POLE	STATION	OFFSET	ELEVATION (TOP OF FOUNDATION)
A1	"T" 10+55.3	42.1' LT	40.35
A2	"T" 10+32.8	26.3' RT	40.71
A3	"T" 11+27.9	26.3' RT	41.11
A4	"T" 12+25.5	45.8' RT	41.20
A5	"T" 19+28.1	40.8' LT	43.00
A6	"T" 19+28.1	39.2' RT	42.70

NOTE: STATION AND OFFSET GIVEN TO CENTER OF LIGHT POLE

DISCONNECT SUPPORT POST SUMMARY TABLE		
POLE	STATION	OFFSET
D1	"T" 11+10.0	39.0' LT
D2	"T" 18+77.0	41.0' RT

NOTE: STATION AND OFFSET GIVEN TO CENTER OF FOUNDATION

ELECTRICAL DRAWING LIST	
E001	LEGEND AND TABLES
E200	ELECTRICAL PLAN TRINITY DRIVE TO STA "T" 16+00
E201	ELECTRICAL PLAN STA "T" 16+00 TO EOP
E300	SINGLE LINE DIAGRAM AND DETAILS

DESIGN BJB  
 DRAWN BJB  
 CHECK BJB  
 APPROVED BJB  
 FILE:

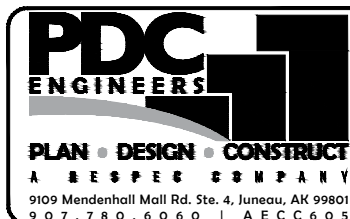
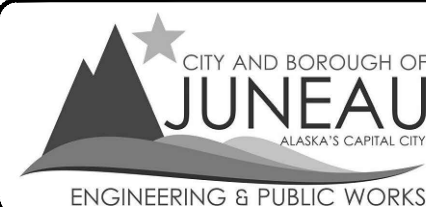

TONGASS BOULEVARD  
 RECONSTRUCTION  
 PHASE I  
 CBJ CONTRACT No. BE21-150  
 CITY & BOROUGH OF JUNEAU, ALASKA

LEGEND AND TABLES

DATE: April 7, 2021  
 PDC No. 20232JN  
 SHEET  
**E001**

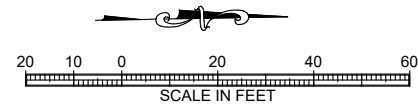
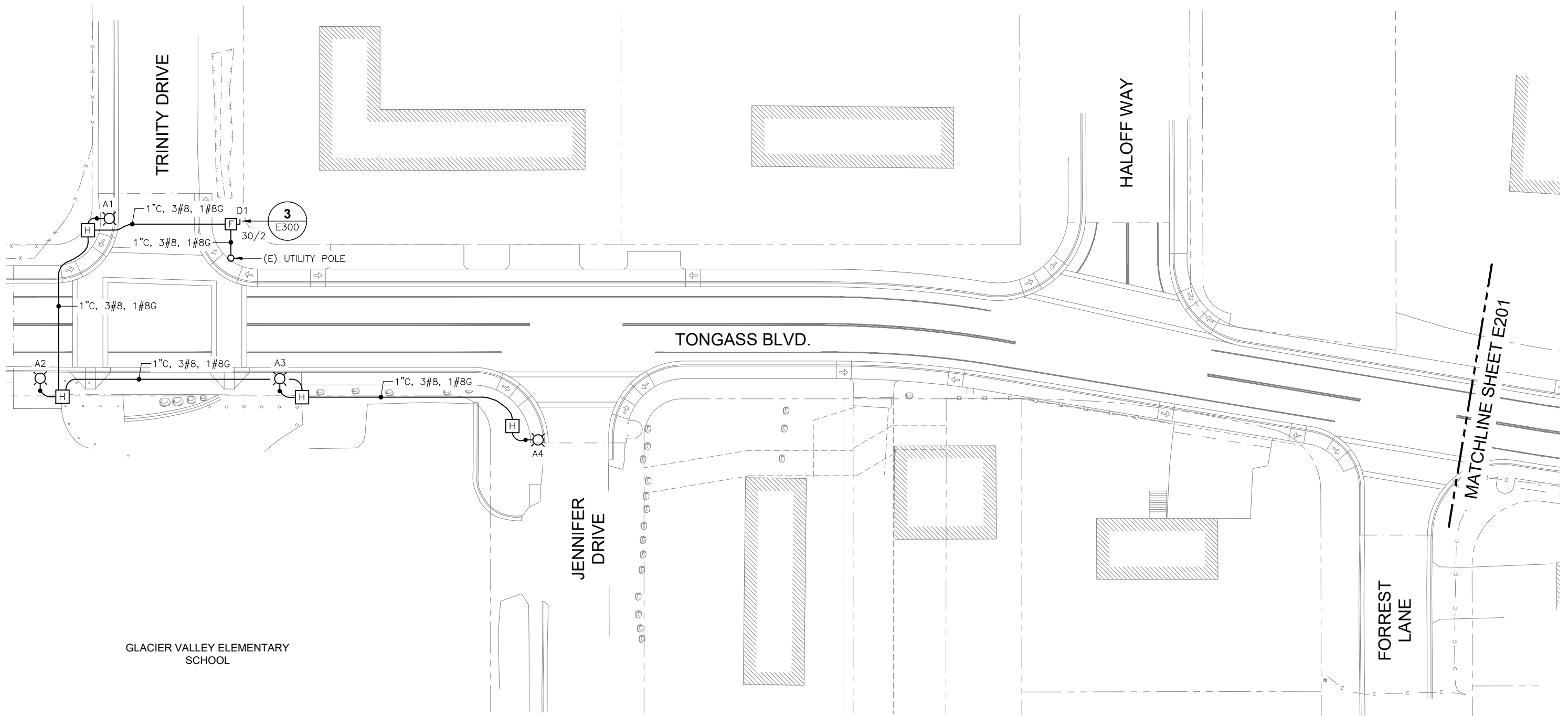

DESIGN: BJB  
 DRAWN: BJB  
 CHECK: BJB  
 APPROVED: BJB  
 FILE:



**TONGASS BOULEVARD RECONSTRUCTION PHASE I**  
 CBJ CONTRACT No. BE21-150  
 CITY & BOROUGH OF JUNEAU, ALASKA

**ELECTRICAL PLAN TRINITY DRIVE TO STA "T" 16+00**

DATE: April 7, 2021  
 PDC No. 20232JN  
 SHEET: **E200**

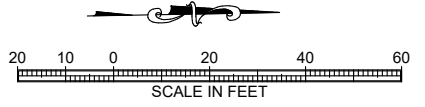
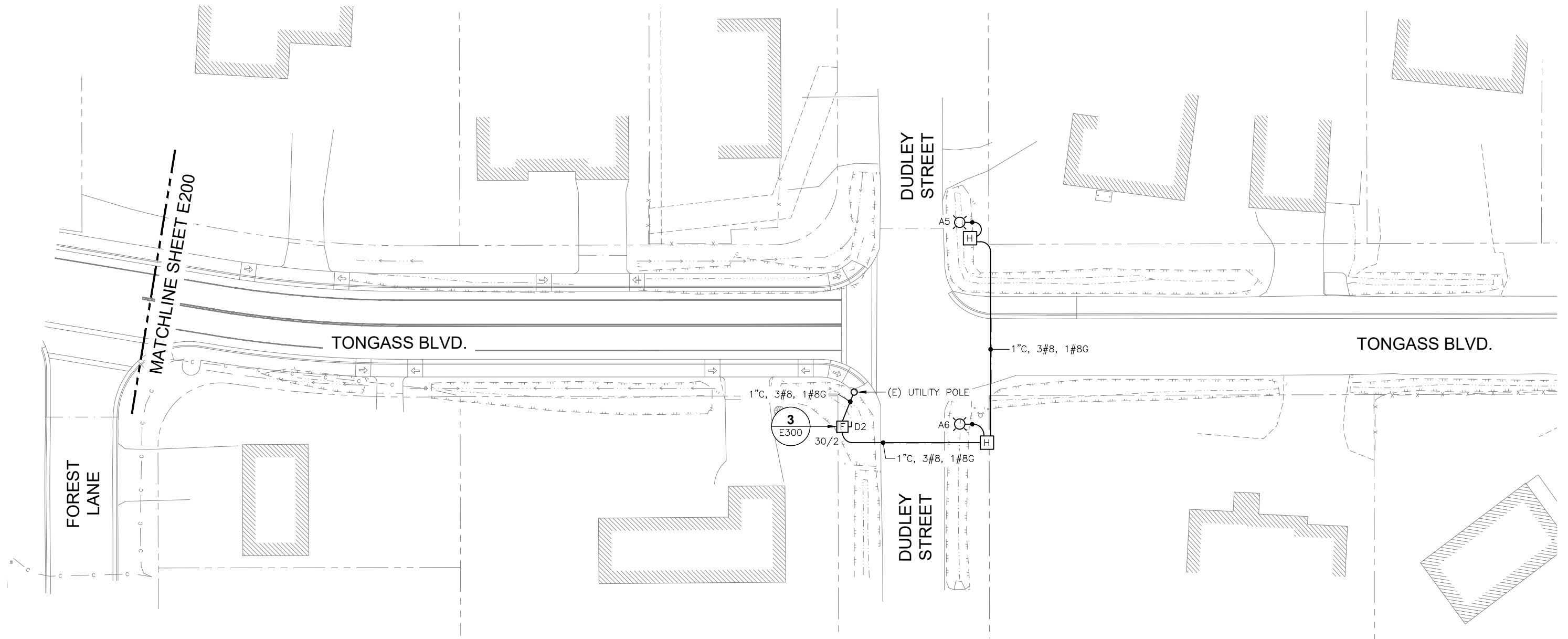

DESIGN BJB  
 DRAWN BJB  
 CHECK BJB  
 APPROVED BJB  
 FILE:



**TONGASS BOULEVARD RECONSTRUCTION PHASE I**  
 CBJ CONTRACT No. BE21-150  
 CITY & BOROUGH OF JUNEAU, ALASKA

**ELECTRICAL PLAN STA "T" 16+00 TO EOP**

DATE: April 7, 2021  
 PDC No. 20232JN  
 SHEET E201

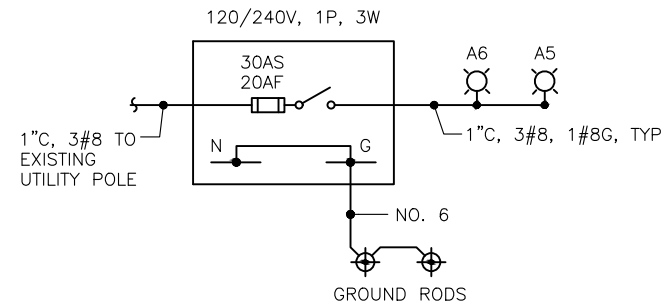
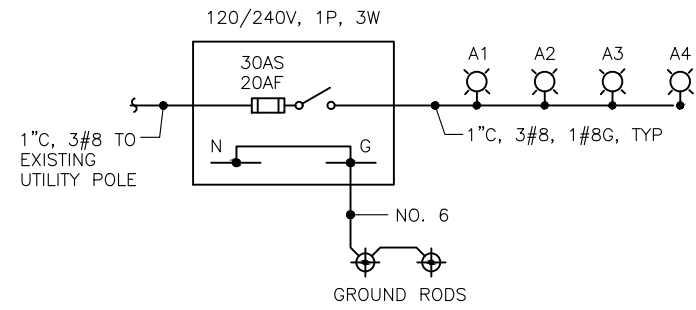

**1 POWER DISTRIBUTION SINGLE LINE DIAGRAM**  
SCALE: NONE

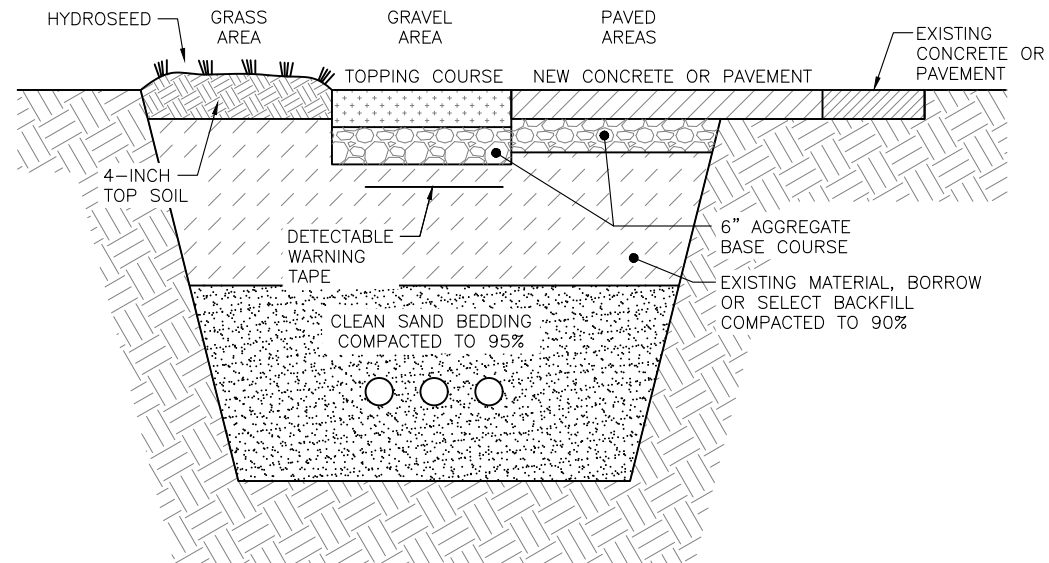

NOTE:  
REFER TO CBJ STANDARD 125 FOR ADDITIONAL REQUIREMENTS.

**2 TYPICAL TRENCH SECTION**  
SCALE: NONE

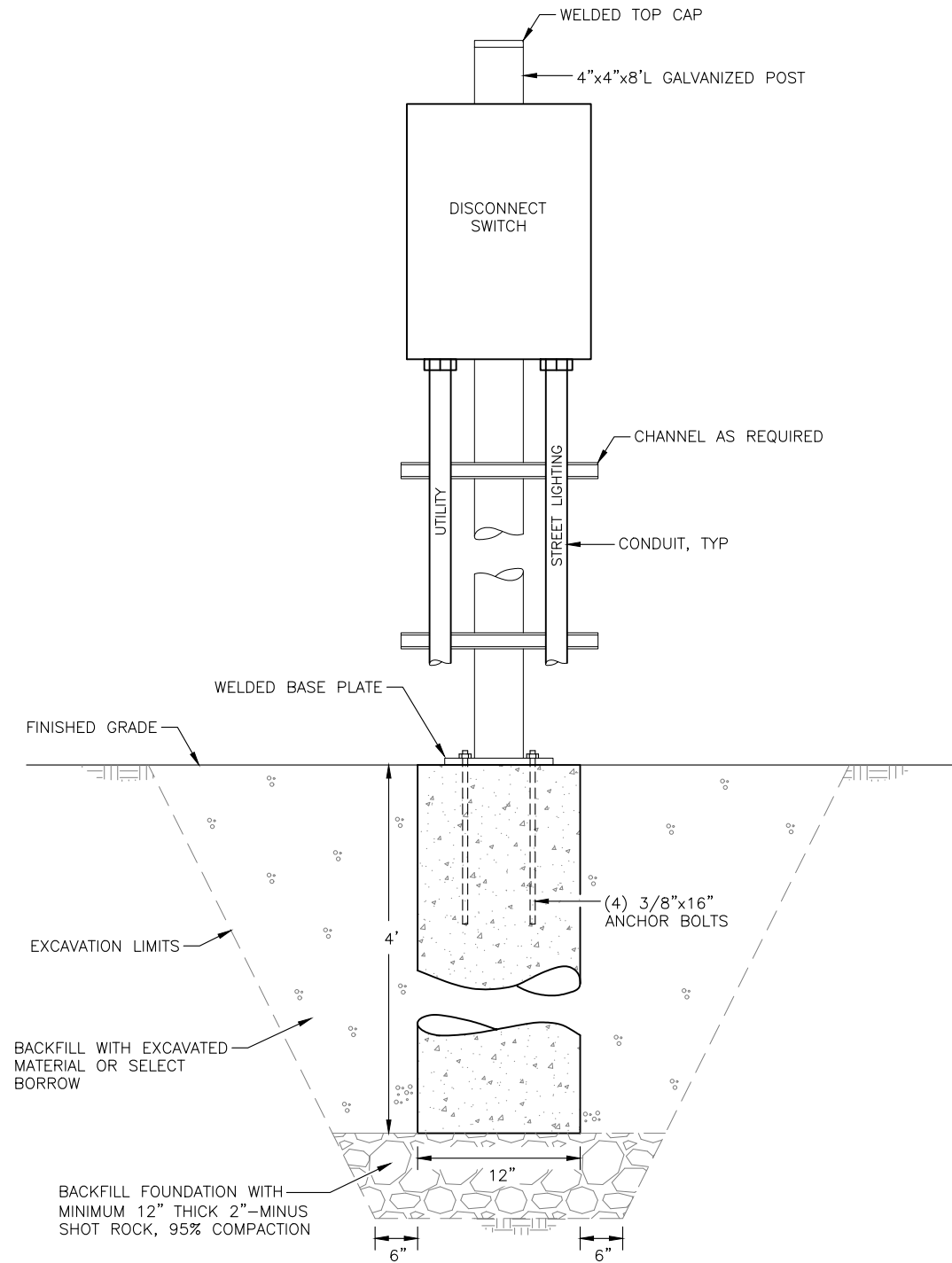

**3 DISCONNECT SWITCH INSTALLATION DETAIL**  
SCALE: NONE

DESIGN: BJB  
DRAWN: BJB  
CHECK: BJB  
APPROVED: BJB  
FILE:

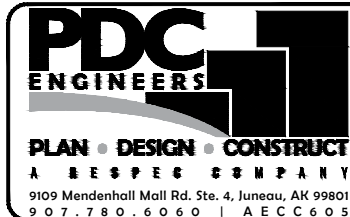
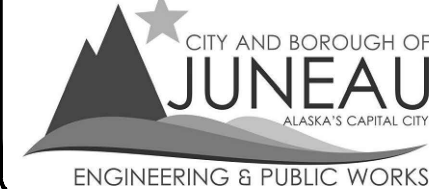

**TONGASS BOULEVARD RECONSTRUCTION PHASE I**  
CBJ CONTRACT No. BE21-150  
CITY & BOROUGH OF JUNEAU, ALASKA

**SINGLE LINE DIAGRAM AND DETAILS**

DATE: April 7, 2021  
PDC No. 20232JN  
SHEET  
**E300**