

SOLID HANDRAIL
DETAIL

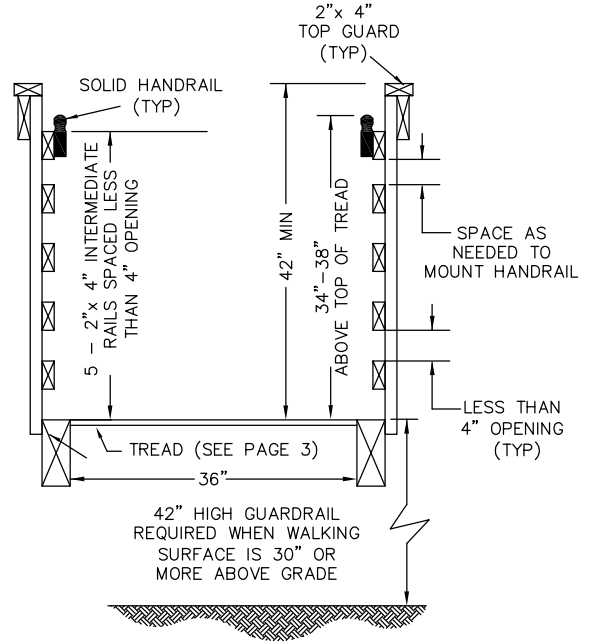

STAIRWAY SECTION

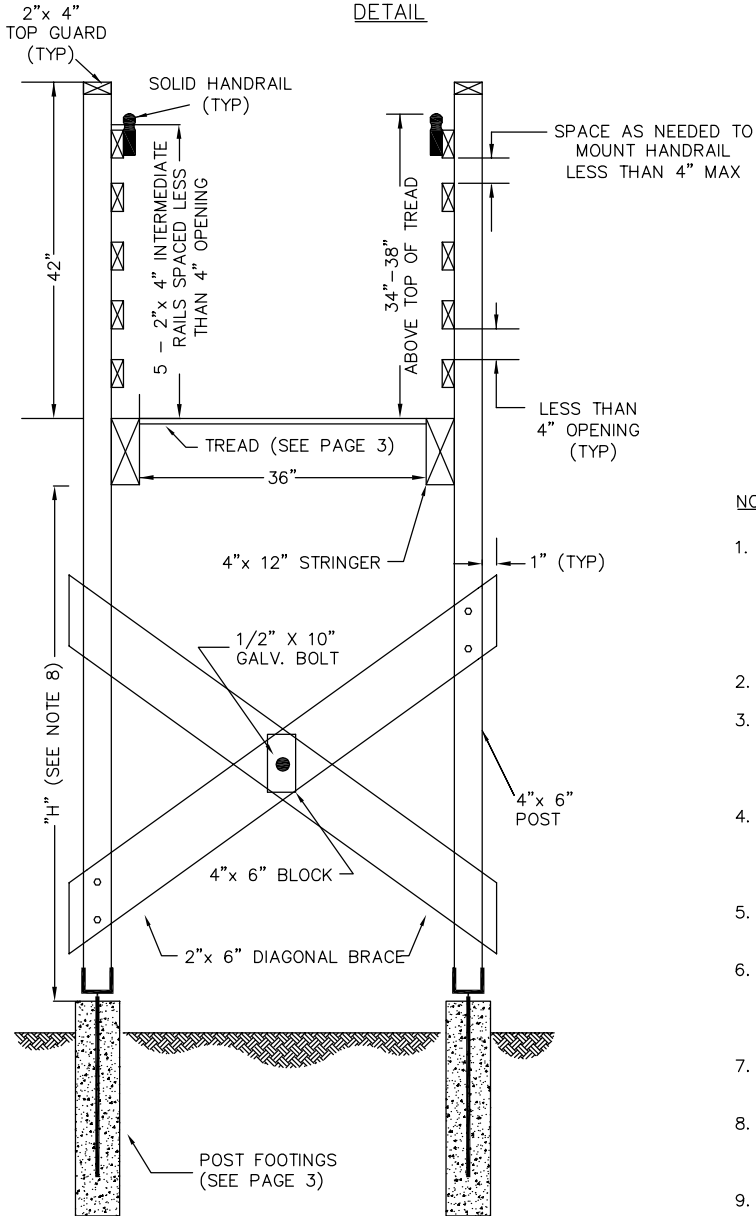

LANDING SECTION

NOTES:

1. STAIRWAY AND LANDING TREAD SHALL BE STEEL GRATING 1" X 3/16" BEARING BARS AND 1/4" CROSS BARS, RYERSON 19W4 OR EQUAL. STAIRWAY TREAD AND LEADING EDGE OF LANDING WILL BE SUPPLIED WITH CARRIER PLATES. MINIMUM TREAD WIDTH SHALL BE 11". GRATING SHALL BE HOT DIP GALVANIZED AFTER FABRICATION IN ACCORDANCE WITH ASTM-A-153.
2. POST BASES SHALL BE GALVANIZED, SIMPSON EPB 44A OR EQUAL.
3. ALL CONNECTIONS SHALL BE MADE WITH GALVANIZED FASTENINGS IN ACCORDANCE WITH THE UNIFORM BUILDING CODE. WASHERS SHALL BE USED ON ALL BOLTS NOT BEARING ON METAL. NO NAILING ALLOWED.
4. DIAGONAL BRACING TO 4"x 6" POST, CONNECTION REQUIREMENTS.
TREADS TO STRINGERS 1/2" x 5" LAG SCREWS (2) EA END
4 X 6 POST TO STRINGER 3/8" x 3" LAG SCREWS (2) EA SIDE
4 X 6 POST TO BASE 1/2" x 10" BOLTS (2) EA
1/2" x 5" BOLTS (2) EA
5. ALL HARDWARE SHALL BE GALVANIZED IN ACCORDANCE WITH ASTM-A-153.
6. ALL WOOD SHALL BE TREATED WITH ACA OR CCA IN ACCORDANCE WITH LP-22. RETENTION OF THE DRY SALT SHALL BE A MINIMUM OF 0.5 LBS. PER CUBIC FOOT. LUMBER SHALL BE HEM-FIR, NO. 2 AND BETTER.
7. FOOTINGS SHALL BE ON UNDISTURBED EARTH AND A MINIMUM OF 32" BELOW THE SURFACE, EXCEPT BEDROCK FOOTINGS.
8. WHERE "H" IS 18" TO 6', 1 PANEL OF "X" BRACING SHALL BE USED. WHERE "H" EXCEEDS 6' TWO PANELS OF "X" BRACING SHALL BE USED.
9. WOOD HANDRAILS SHALL BE SMOOTH, SPLINTER FREE AND MADE OF ROT RESISTANT WOOD.

SCALE:	NTS	DATE:	7/24/98	CITY AND BOROUGH OF JUNEAU, ALASKA	
DRAWN BY:	STAFF	CHECKED BY:	JB/STAFF		STANDARD STAIRWAY
APPROVED BY:	<i>[Signature]</i>		REVISED:	8/14/2011	STANDARD 122-1